

E4-WM5-Y265A00

MOUNTING INSTRUCTION



ALL DRAWINGS ARE
GENERALIZED!
BRACKETS, ETC. SPECIFIC
TO STRUT ARE NOT SHOWN!

SUBARU Impreza - 09.00

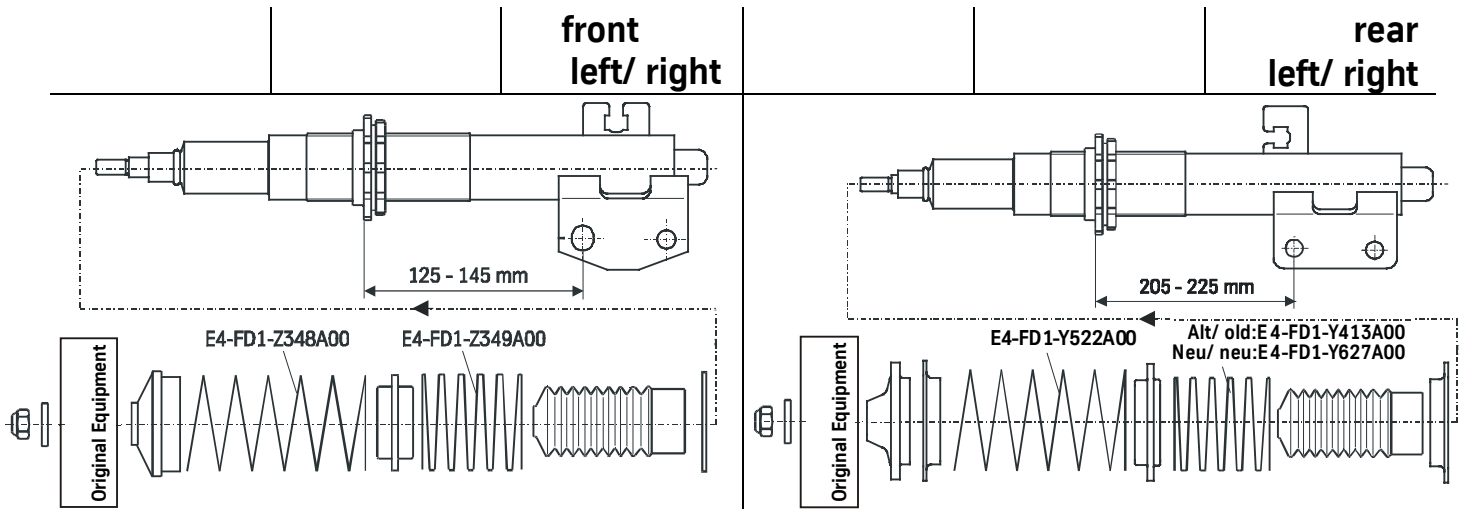

SUBARU Impreza 10.00 -

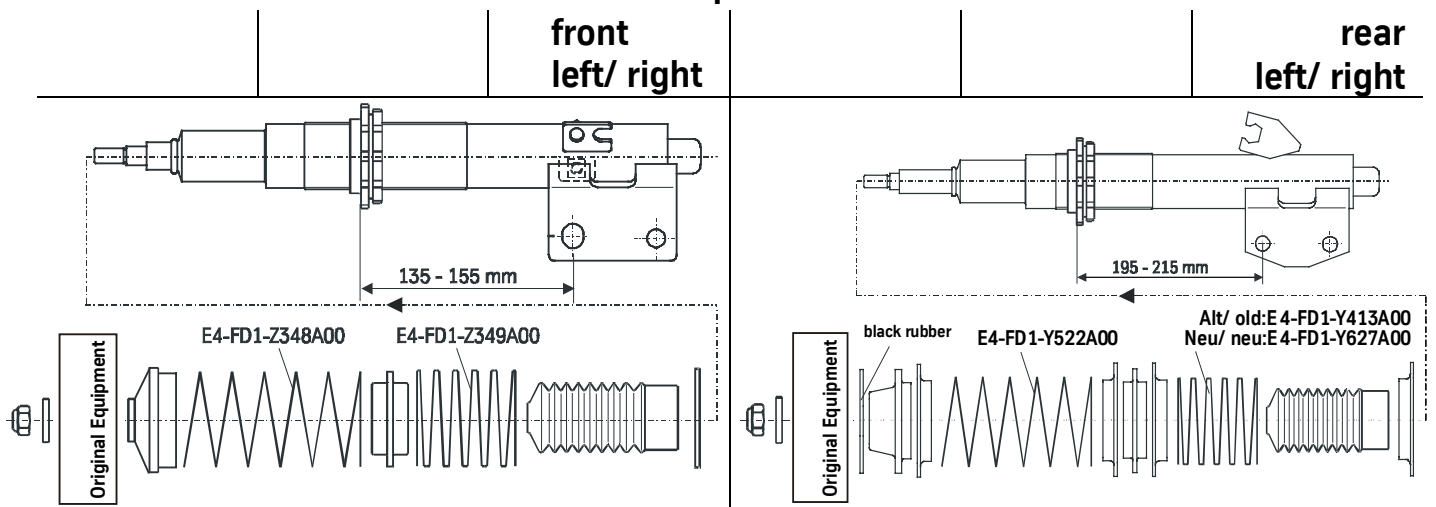

When fitting the intermediate ring (3), care must be taken to ensure that the shorter side of the ring is fit-fitted to the helper spring (4).

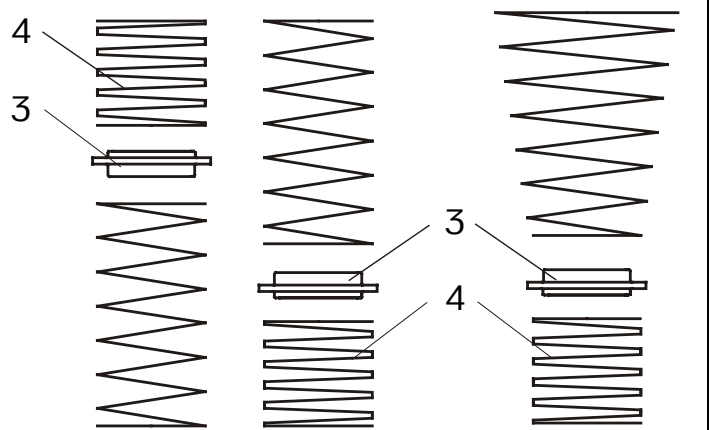

E4-WM5-Y265A00

MOUNTING INSTRUCTION



Remove front/ rear

Place vehicle on a chassis hoist, lift it and remove wheels.



The lower control arm must be supported by suitable means!

Remove bottom mount.

Remove top fixing nut from support bearing.
Do not remove center nut at this time!

Remove complete strut and clamp it in an appropriate strut vise.

Using a suitable spring compressor, compress suspension spring until tension on support bearing is released.

Release center nut and remove original mounting parts and coil spring. Please refer to diagram to identify which parts will be replaced with BILSTEIN- supplied components.

Install front/ rear

Assemble BILSTEIN and/ or original mounting parts, as well as the new BILSTEIN springs on the BILSTEIN strut in reverse sequence of removal.



The adjustment range for front and rear axle (see lowering list) must be observed strictly!

The correct mounting position of the suspension springs can be determined by the printing on the springs; install them with the print upright.

Fit assembled BILSTEIN strut to the vehicle in reverse sequence to removal.

						List
M8	M 10	M 12	M 14	M 16		
13	25	45	72	110	Thread	
10	19	34	54	83	Torque Nm	
					Torque ft lb	

E4-WM5-Y265A00 MOUNTING INSTRUCTION



general instructions for force adjustment

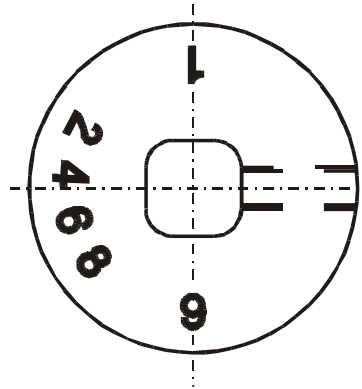

position **9** = **soft** (clockwise direction)

position **1** = **firm** (counter- clockwise direction)

During the adjustment you will hear a positive „click“ at each position of the adjustment.

The adjusting element of the struts is located at the bottom edge of the strut, covered by a blue plastic cap. That cap must be removed before adjusting. After the adjustment the cap must be replaced again.

FOR THE TORQUE AND RE-TORQUE OF NUTS THE USE OF AN IMPACT SCREWDRIVER IS NOT ALLOWED BECAUSE THIS WOULD DESTROY THE WRENCH. SELF- LOCKING NUTS MUST ONLY BE **USED ONCE**

ALL RUBBER MOUNTED **STRUTS/ SHOCK ABSORBERS** MUST BE TIGHTENED AFTER THE VEHICLE IS LET DOWN TO THE GROUND. ALL OTHER KIND OF MOUNTING, LIKE BRACKETS FOR EX. MUST BE TIGHTENED BEFORE THE VEHICLE IS LET DOWN TO THE GROUND.

E4-WM5-Y265A00

MOUNTING INSTRUCTION



AFTER INSTALLATION PLEASE OBSERVE THE FOLLOWING POINTS:

After installing the suspension system, caster and camber must be checked and adjusted according to manufacturer's specifications. Check and reset load-dependent brake compensator and ABS system according to manufacturer's specifications.

Check and adjust headlight aim.

Because the vehicle has been lowered, freedom of movement for all wheel-/tire-combinations must be checked.

Lowering

The lowering we indicates here refers to the stationary height of a new vehicle. To obtain comparable measured values, the influence of the wheel/ tire combination on the stationary height to be calculated, should be eliminated. So the vertical distance from wheel hub centre to the lower edge of the mudguard should be compared prior to/ after conversion. The extension of lowering has to be reduced by the series lowering.

type	SUBARU Impreza (GC, GF) - 09.00	SUBARU Impreza (GDA) 10.00 -
B16	F4-GM5-8603	F4-GM5-8620
front	up to approx. 50 mm	up to approx. 45 mm
rear	Up to approx. 35 mm	up to approx. 45 mm
adjustement range front	125 – 145 mm	205 – 225 mm
adjustement range rear	135 – 155 mm	195 – 215 mm

E4-WM5-Y265A00

MOUNTING INSTRUCTION



fig.1

Carefully check that the spring will not become loose at fully extended shock absorber length (max. lowering)!

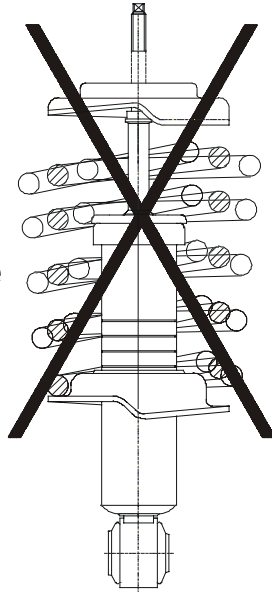

fig.2

The wheel or other chassis components must not touch spring plate, bracket or bracket hose holder (max. lowering)

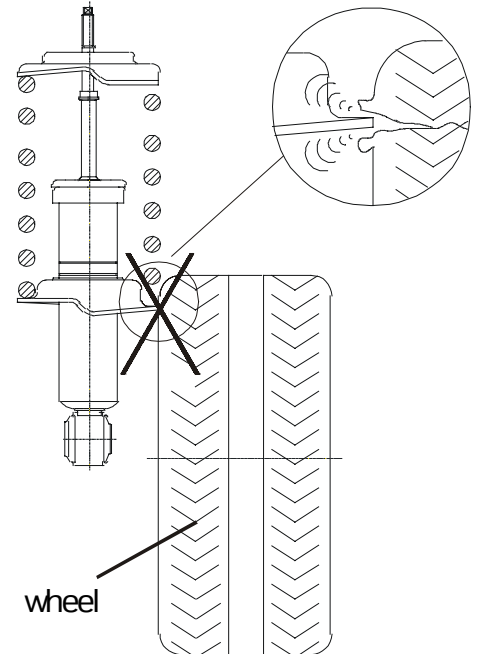

fig.3

The spring must not be fully compressed when the shock absorber is fully compressed (upper groove)!

