

instructions for force adjustment

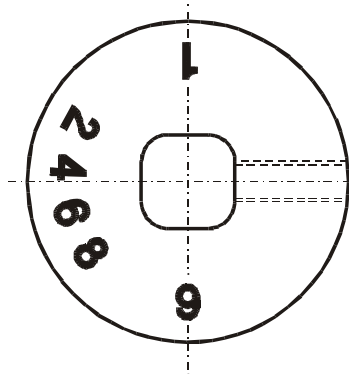

position **9** = **soft** (clockwise direction)
 position **1** = **firm** (counter- clockwise direction)

During the adjustment you will hear a positive „click“ at each position of the adjustment.

Instruction for the front axle

The adjusting element of the front struts is located at the bottom edge of the strut, covered by a blue plastic cap. That cap must be removed before adjusting. After the adjustment the cap must be replaced again.

- list of torques

	M8	M 10	M 12	M 14	M 16	Thread
	13	25	45	72	110	Torque Nm
	10	19	34	54	83	Torque ft lb

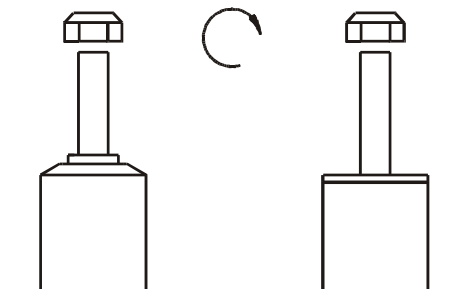

DO NOT USE IMPACT TOOLS FOR LOOSENING OR TIGHTENING FASTENERS, BECAUSE THIS MAY DESTROY THE THREADS. SELF- LOCKING NUTS MUST ONLY BE USED ONCE!



**After installation please observe
the following points:**

After installing the suspension system, caster and camber must be checked and adjusted according to manufacturer's specifications.
Check and reset load- dependent brake compensator and ABS system according to manufacturer's specifications.

Check and adjust headlight aim. -

Because the vehicle has been lowered, -
freedom of movement for all wheel-/
tire- combinations must be checked.

ALL RUBBER- MOUNTED STRUT/ DAMPER ATTACH-
MENTS MUST NOT BE FULLY TIGHTENED
UNTIL AFTER THE SUSPENSION SYSTEM IS LOADED
(WHEELS ON THE GROUND). OTHER MOUNTING
FASTENERS (FOR EXAMPLE BRACKETS)
MUST BE SECURELY TIGH-TENED BEFORE LOAD
IS PLACED ON THE SUSPENSION SYSTEM.

ALL DIAGRAMS ARE GENERALIZED
AND NOT TO SCALE!
BRACKETS, ETC. SPECIFIC TO
STRUT ARE NOT SHOWN!

Remove

Place vehicle on a chassis hoist, lift it and remove wheels.

Vehicles equipped **with xenon headlight** the sensor for the headlamp levelling controller must be removed before.



The lower control arm must be supported by suitable means!

Remove bottom mount.

Remove top fixing nut from support bearing. Do not remove center nut at this time!

Remove complete strut and clamp it in an appropriate strut vise.

Using a suitable spring compressor, compress suspension spring until tension on support bearing is released.

Release center nut and remove original mounting parts and coil spring. Please refer to diagram to identify which parts will be replaced with BILSTEIN-supplied components.

Install

Assemble BILSTEIN and/ or original mounting parts, as well as the new BILSTEIN spring on the BILSTEIN strut in reverse sequence of removal.



IMPORTANT! Spring plates must not be adjusted outside the ranges specified below!

The correct mounting position of the suspension springs can be determined by the printing on the springs; install them with the print upright.

Do not reuse original-bumper, since BILSTEIN-strut has built-in bump stop.

Fit assembled BILSTEIN strut to the vehicle in reverse sequence to removal.

IMPORTANT! Spring plates must not be adjusted outside the ranges specified below!

Manufacturer	Volkswagen, VW		
ABE-/ EG- BE- No.	e1*96/79*0071*.. e1*98/14*0071*.. e1*2001/116*0071*..	e1*97/27*0106*.. e1*98/14*0106*.. e1*2001/116*0106*..	e1*2001/116*0205
type designation	1J	9C	1Y
model	Golf 4 sedan, Bora sedan	New Beetle	New Beetle Cabrio

Manufacturer	AUDI	Seat
ABE-/ EG- BE- No.	e1*95/54*0042*.. e1*98/14*0042*..	e9*97/27*0026*.. e9*98/14*0026*..
type designation	8L	1M
model	AUDI A3	Toledo, Leon

FRONT		
spring part number	main spring E4-FD1-Z348A00	helper spring E4-FD1-Z349A00
shock absorber part number	VE3-4446 without damping force adjustment or VM3-4534 with damping force adjustment	
permissible adjustment range	maximum permissible axle load up to 1020 kg (2244 lb) 195 – 215 mm* = 20 mm range	maximum permissible axle load up to 1060 kg (2332 lb) 200 – 215 mm* = 15 mm range
* measurement: top edge of spring seat down to the center of bottom mounting screw		

REAR		maximum permissible axle load 1010 kg (2222 lb)
spring part number	main spring E4-FD1-Y373A00	
shock absorber part number	BE5-2825 without damping force adjustment or BM5-2893 with damping force adjustment	
permissible adjustment range	35 – 55 mm* = 20 mm range	
* measurement: top edge of spring seat down to original spring seat		

- If vehicle is equipped with a spoiler, lower rear panel and/ or special exhaust system, be aware of reduced slope angle available (be careful of ramps, etc.)
- All original wheel/ tire combinations can be used,
except 205/ 55R16 on 7Jx16ET42
In that case a wheel spacer 3- 5 mm must be used on front axle (axle 1).
For the special wheel/ tire combination
225/ 45 R17 on 8Jx17 ET38
at front axle (axle 1) no wheel spacers are requested.
- ⁵ ➤ because of the upsized compression travel at rear axle (axle 2) all registered special-wheel/ tire combinations must be checked after modification in reference to the freedom of motion.
critical location: clearance of outer tire sidewall on top of wheel center, drive shaft and stabilizer.
Until this check is done the vehicle can only be operated with production wheel/ tire combinations.
- ground clearance of tested vehicle: **100 mm**

OE = Original Anbauteile

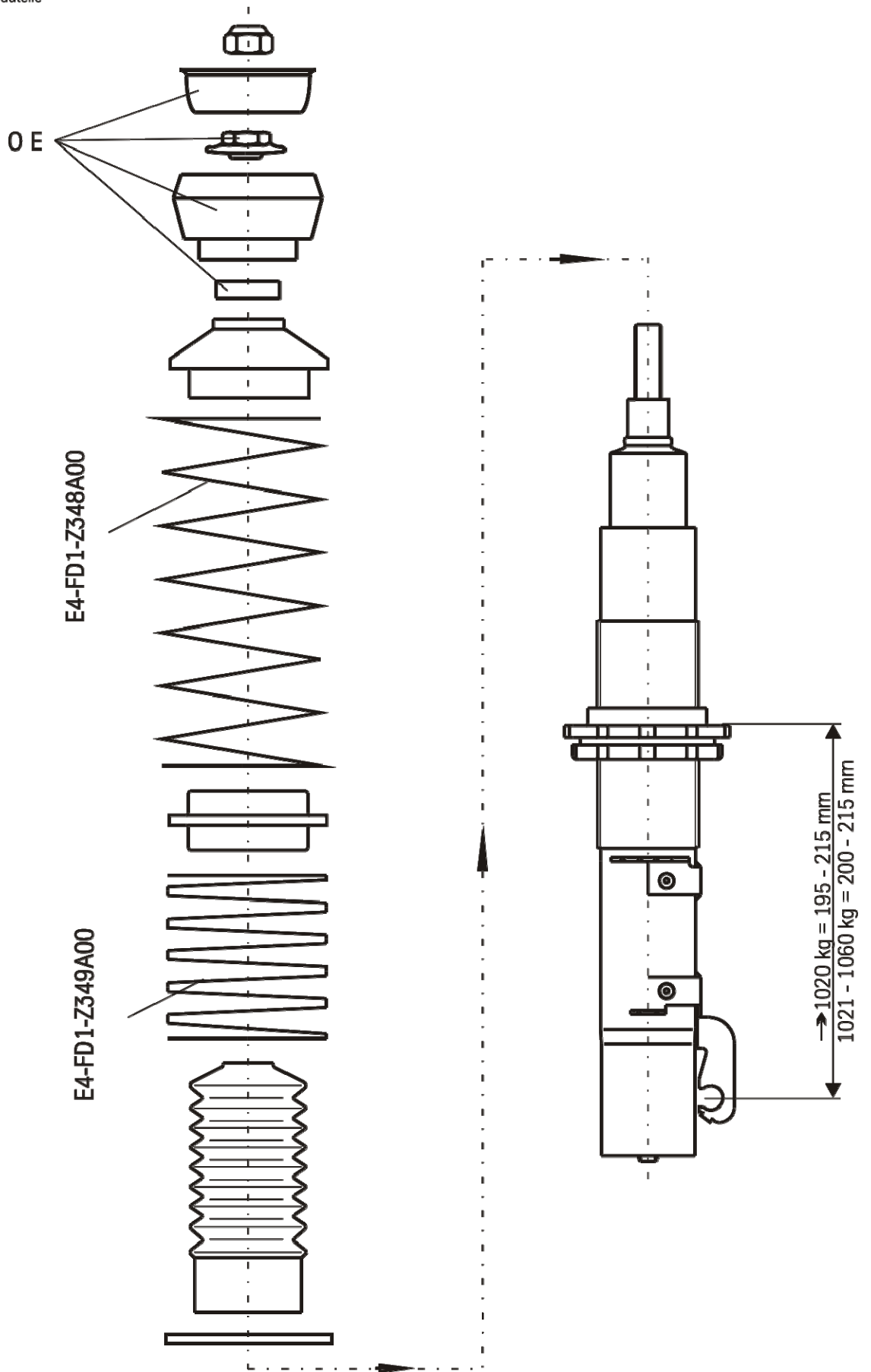

Remove

Place vehicle on a chassis hoist,
lift it and remove wheels.



The lower control arm must be supported by suitable means!

Remove top and bottom fixing
mount from support bearing.

Remove shock absorber and
original mounting parts.

Install

Fit BILSTEIN and/ or original mounting
parts in BILSTEIN shock absorber in
reverse sequence of removal.

Fit BILSTEIN shock absorber to the vehicle
in reverse sequence of removal.

- mounting instuction for rear axle height adjustment

The lock nut (*) delivered in a few Kits is not been required.

