

E4-WM5-Y180A00

MOUNTING INSTRUCTION



After installation please observe the following points:

- After installing the suspension system, caster and camber must be checked and adjusted according to manufacturer's specifications.
- Check and reset load- dependent brake compensator and ABS system according to manufacturer's specifications.
- Check and adjust headlight aim.
- Because the vehicle has been lowered, freedom of movement for all wheel-/ tire- combinations must be checked.
- All rubber- mounted strut/ damper attachments must not be fully tightened until AFTER the suspension system is loaded (wheels on the ground). Other mounting fasteners (for example brackets) must be securely tight-tened BEFORE load is placed on the suspension system.

All diagrams are generalized
and not to scale!
Brackets, etc. specific to
strut are not shown!

Before installation please observe the following points:

- Read all information in this manual carefully.
- All suspension components are fitted and removed acc. to the manufacturer's specifications for fitting and removing, if not otherwise required in these instructions.
- Check that dimensions and fastening points are comparable between the original and Bilstein shock absorbers.
- Directional references (left, right, front, rear) are always with reference to the driving direction.
- The test vehicles are left- hand drive cars.

E4-WM5-Y180A00 MOUNTING INSTRUCTION



1. BILSTEIN shock absorber with original spring
2. BILSTEIN shock absorber with BILSTEIN spring
3. Original shock absorber with BILSTEIN spring

Install

Removal

Fit original/ BILSTEIN mounting parts on BILSTEIN-strut in reverse sequence to removal, except for dust cover and bump stop, since BILSTEIN- strut has built in bump stop. If there is no dust cover delivered by BILSTEIN, the original one is to be reused.

Place vehicle on a chassis hoist, lift it and remove wheels.

Disconnect the negative battery pole.



Before releasing the spring, care is to be taken to ensure that the spring rest in the cut outs of top and bottom spring plate!

The correct mounting position of the suspension springs can be determined by the printing on the springs; install them with the print upright.

Fit assembled BILSTEIN strut to the vehicle in reverse sequence of removal.

Connect the negative battery pole again.



The lower control arm must be supported by suitable means!

Remove bottom mount.

If necessary release brake hose/ brake hose holder/ stabilizer/ ABS- hose and/ or swing- support at strut.

At support suspension arm, screw on top, inside must be released a little.

Remove top fixing nuts from support bearing. Do not remove center nut at this time!

Remove complete strut and clamp it in an appropriate strut vise.

Using a suitable spring compress and compress suspension spring until tension on support bearing is released.

Release center nut and remove original mounting parts and coil spring. Please refer to diagram to identify which parts will be replaced with BILSTEIN- supplied components.

ATTENTION: Some models are equipped with plastic- dustcover cap also. This cap **do not** reuse!

E4-WM5-Y180A00 MOUNTING INSTRUCTION



list of torques

	M8	M 10	M 12	M 14	M 16	Thread
	13	25	45	72	110	Torque Nm
	10	19	34	54	83	Torque ft lb

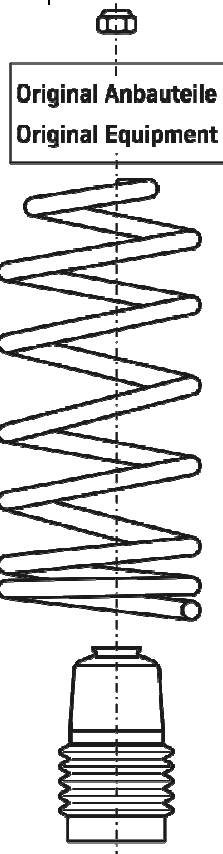
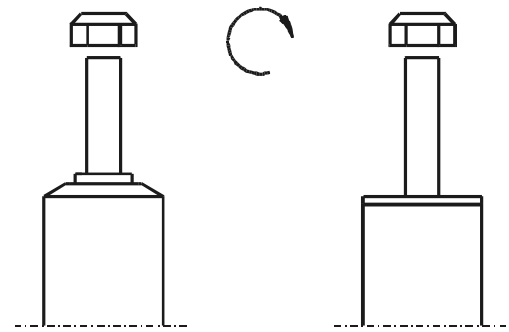

Do not use an impact tool to loosen or tighten fasteners due to possible damage to the product. Self- locking nuts must only be used once!

