

# E4-WM5-Y488A00 MOUNTING INSTRUCTION



**Do not use an impact tool to loosen or tighten fasteners due to possible damage to the product. Self- locking nuts must only be used once!**

## **Before installation please observe the following points:**

- Read all information in this manual carefully. All suspension components are fitted and removed acc. to the manufacturer's specifications for installing and removal, if not otherwise required in these instructions.
- Check the product for all components before starting installation!
- Check that dimensions and fastening points are comparable between the original and BILSTEIN shock absorbers.
- Remove the negative battery pole.
- Directional references (left, right, front, rear) are always with reference to the driving direction.
- The tested vehicles are left- hand drive vehicles.
- The installed location of the BILSTEIN DampTronic cable system is optional. The system components may be located anywhere in the vehicle in accordance with the specifications of manufacturer and BILSTEIN.

## **After installation please observe the following points:**

- After installing the [suspension system](#), caster and camber must be checked and adjusted according to manufacturer's specifications.
- Check and reset load- dependent brake compensator and ABS system according to manufacturer's specifications.
- Check and adjust headlight setting.
- If the vehicle has been lowered, freedom of movement (clearance) for all wheel/ tire combinations must be checked.
- All rubber- mounted strut/ damper attachments must not be fully tightened until AFTER the suspension system is loaded (wheels on the ground). Other mounting fasteners (for example brackets) must be securely tightened BEFORE load is placed on the suspension system.
- Connect the negative battery pole.

# E4-WM5-Y488A00

## MOUNTING INSTRUCTION

### Tabelle Anzugsmomente - list of torques

	M8	M 10	M 12	M 14	M 16	Thread
	13	25	45	72	110	Torque Nm
	10	19	34	54	83	Torque ft lb

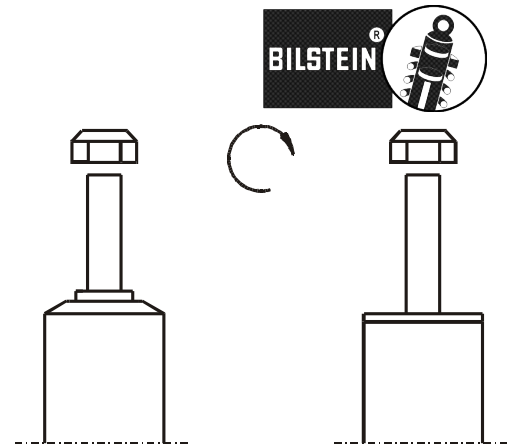

All diagrams are generalized and not to scale!

Brackets, etc. specific to strut are not shown!

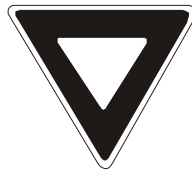

# E4-WM5-Y488A00 MOUNTING INSTRUCTION



Front axles left/right B4/ B6 DampTronic

**OE=** Original Equipment

**B=** Delivered by BILSTEIN

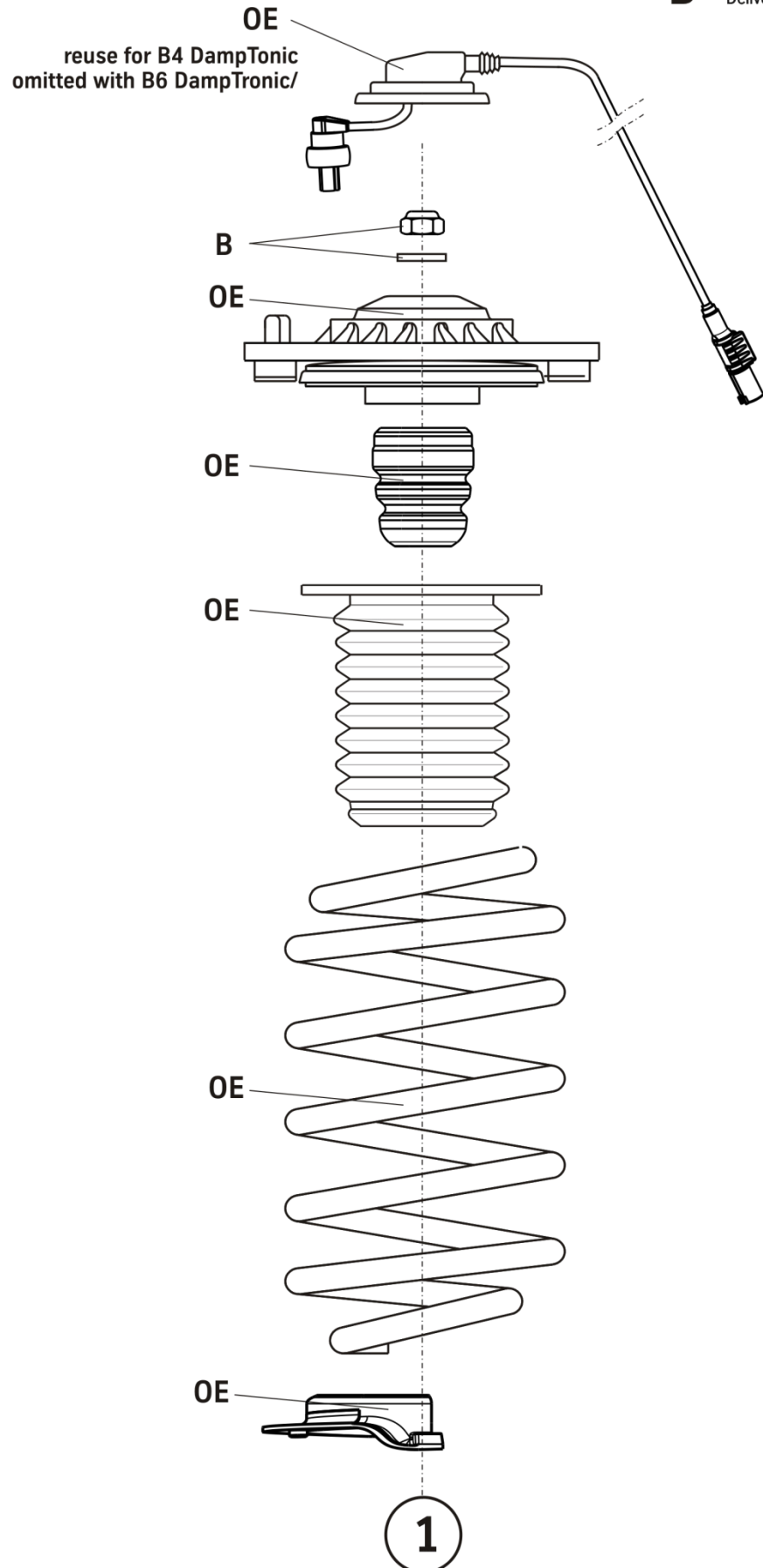

**E4-WM5-Y488A00**  
**MOUNTING INSTRUCTION**



**Front axles left/right B6 DampTronic**

**OE=** Original Equipment

**B=** Delivered by BILSTEIN

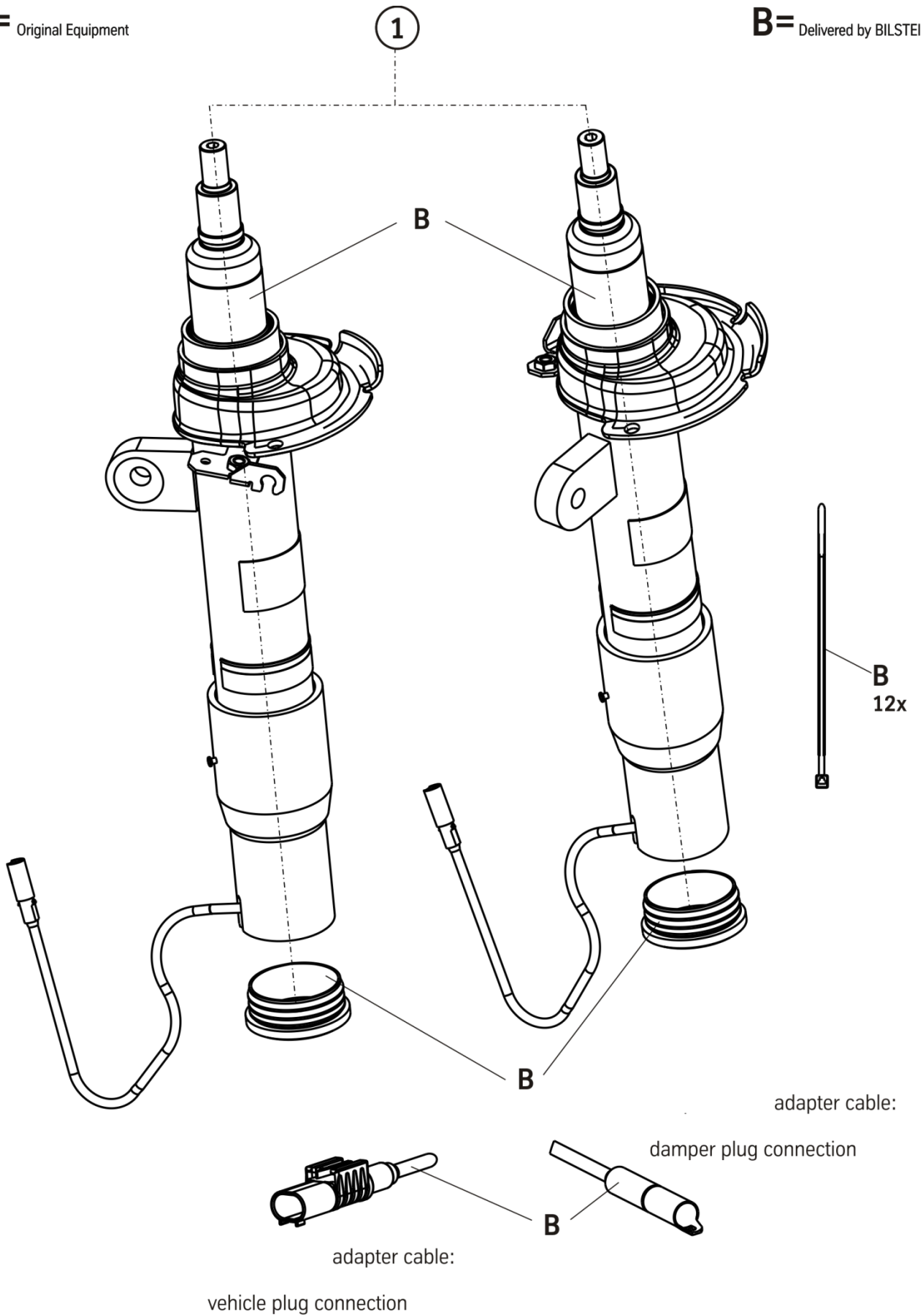

# E4-WM5-Y488A00 MOUNTING INSTRUCTION



Front axles left/right B4 DampTronic

**OE=** Original Equipment

**B=** Delivered by BILSTEIN

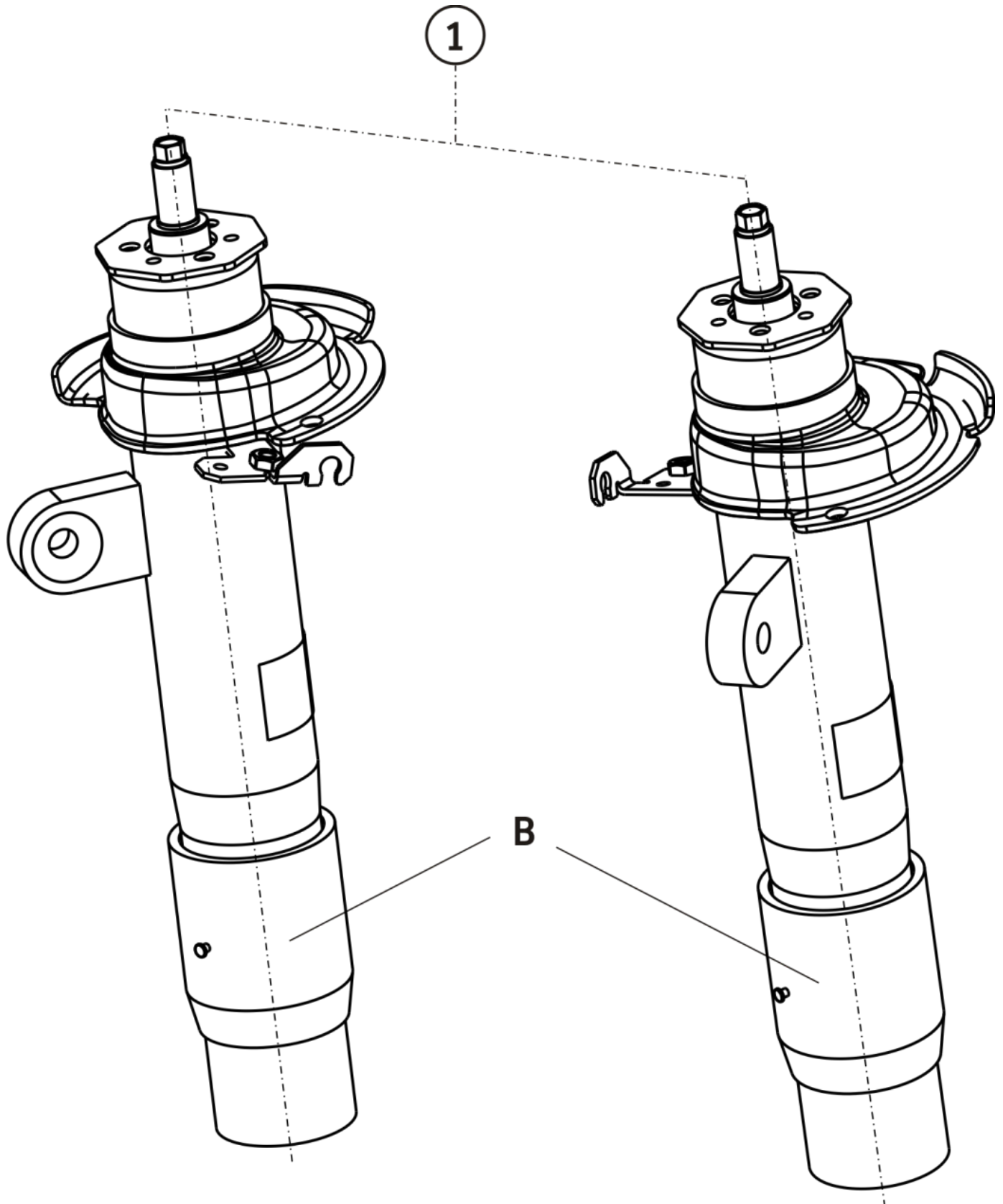

# E4-WM5-Y488A00 MOUNTING INSTRUCTION



## Removal

Place vehicle on a wheel- free car hoist, lift it and remove wheels.

Vehicles equipped **with xenon headlight** the movable element of sensor for the headlamp levelling controller must removed before.



**Pay attention that support wires of brake system are strain-free during removal. Stabilization by suitable means is demanded.**

Remove bottom mounting.

If necessary release brake hose/ brake hose holder/ acceleration sensor/ stabilizer/ ABS- hose and/ or swing-support at strut.

Detach cable connection from strut.

Remove top fixing nuts from support bearing.

**Do not remove central nut at this time!**

Remove complete strut and clamp it in an appropriate strut vice.

Using a suitable spring compressor, compress suspension spring until support bearing is free to move.

Release centre nut and remove original mounting parts and coil spring. Please refer to diagram to identify which parts will be replaced with BILSTEIN- supplied components.

## Installing

Fit original/ BILSTEIN mounting parts on strut in reverse order to removal.

The original spring pad, bumper and dust cover must be reused!



**Before releasing the spring, care is to be taken to ensure that the spring rests in the cut outs of top and bottom spring plate!**

Fit assembled BILSTEIN strut to the vehicle in reverse order to removal.

# E4-WM5-Y488A00 MOUNTING INSTRUCTION



## Installation of cable harness for electromagnetic valve B6 DampTronic

Connect the adapter cable delivered by BILSTEIN to the plug at BILSTEIN strut. Lead the cable through wheelhouse opening (Arrow; **pic 1**) and fix it to the original cable harness by using cable clips (**pic.2**).

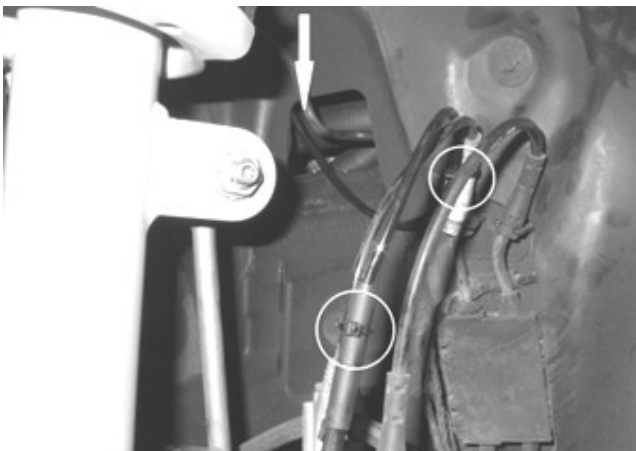

pic 1

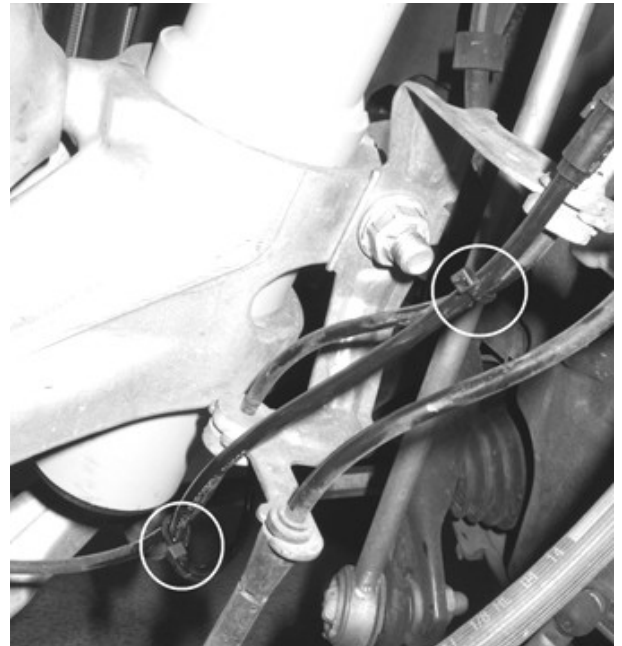

pic 2



Fit the cable along dome on top.

pic 3

Finally connect plug housing to original fastening clip and fix it by using cable clips delivered by BILSTEIN along vehicles cable harness.



pic 4

# E4-WM5-Y488A00 MOUNTING INSTRUCTION



## **Connect BILSTEIN B4 DampTronic**

Connect the vehicles original plug to the piston rod on top of BILSTEIN strut