

# E4-WM5-Y301A00 MOUNTING INSTRUCTION



## Removal

Place vehicle on a chassis hoist,  
lift it and remove wheel



***The lower control arm must be supported by suitable means!***

Remove top and bottom mount.

Remove complete shock absorber  
and original mounting parts.

## Fitting

Fit BILSTEIN and/ or original mounting parts  
on BILSTEIN shock absorber in reverse  
sequence to removal.

Fit BILSTEIN shock absorber to the vehicle  
in reverse sequence of removal.

All rubber- mounted strut/ damper attachments  
must not be fully tightened until AFTER the  
suspension system is loaded ( wheels on the  
ground). Other mounting fasteners ( for example  
brackets) must be securely tightened BEFORE  
load is placed on the suspension system.

### list of torques

	M8	M 10	M 12	M 14	M 16	Thread
	13	25	45	72	110	Torque Nm
	10	19	34	54	83	Torque ft lb

FOR THE REMOVAL AND INSTALLATION  
OF NUTS, IMPACT TOOLS MUST NOT  
BE USED BECAUSE THIS WOULD DAMAGE  
THE MOUNT THREADS.  
SELF- LOCKING NUTS MUST  
ONLY BE **USED ONCE!**



ALL DIAGRAMS ARE GENERALIZED  
AND NOT TO SCALE!  
BRACKETS, ETC. SPECIFIC TO  
STRUT ARE NOT SHOWN!

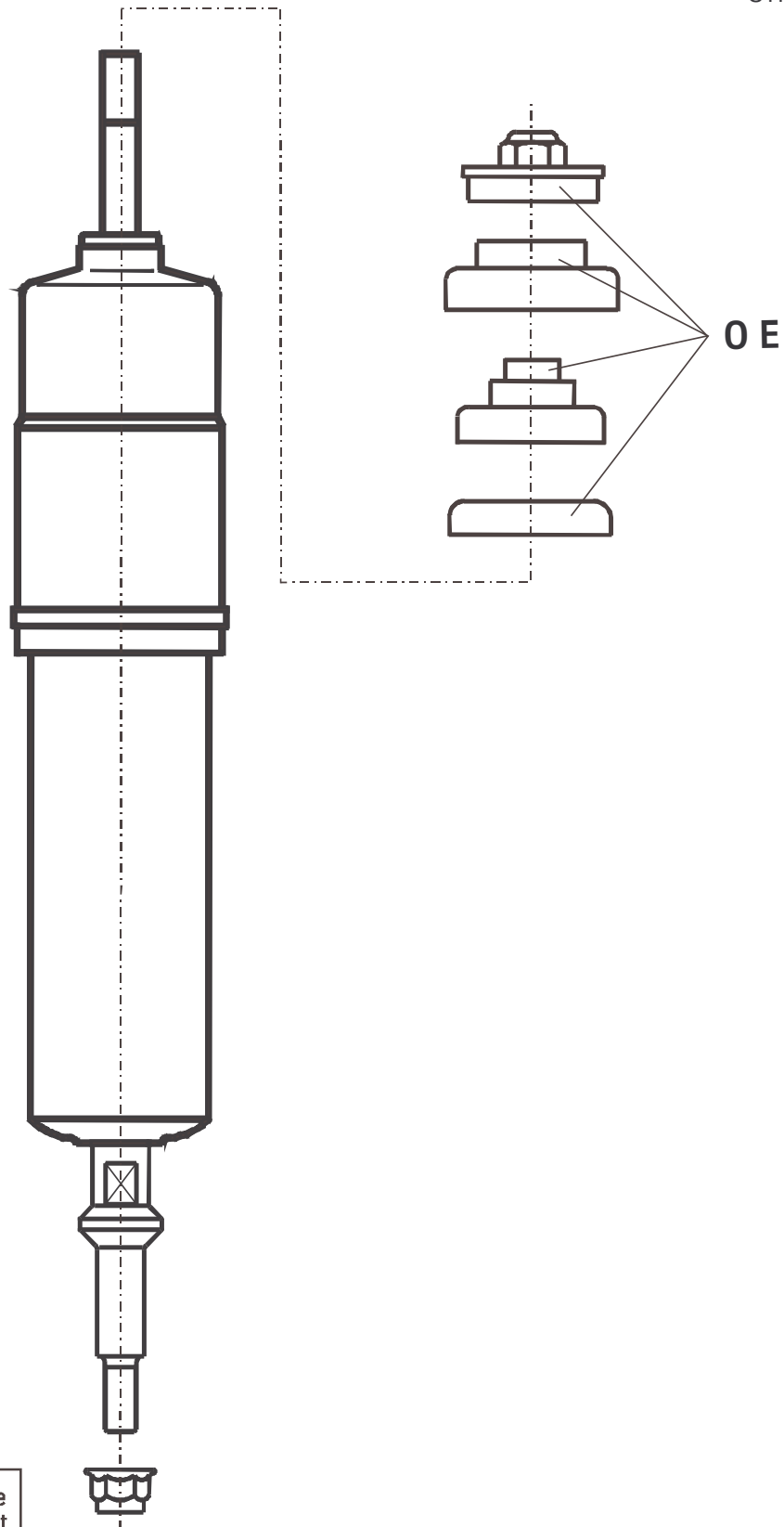

**OE** = Original Anbauteile  
Original Equipment