

# E4-WM5-Y261A01

## MOUNTING INSTRUCTION



### Removal:

Place vehicle on a chassis hoist, lift it and remove wheels.

***The lower control arm must be supported by suitable means!***

Release bottom steering arm/ ABS line/ stabilizer/ brake hose and headlight range adjustment sensor (Xenon).

Remove bottom mount and top fixing nuts from support bearing.

**Do not remove centre nut at this time!**

Remove complete strut and clamp it in an appropriate strut vice.

Using a suitable spring compressor, compress suspension spring until tension on support bearing is released.

Release centre nut and remove original mounting parts and coil spring. Please refer to diagram to identify which parts will be replaced with BILSTEIN- supplied components.

### Installing:

Assemble BILSTEIN and/ or original mounting parts, as well as the new BILSTEIN spring on the BILSTEIN strut in reverse sequence of removal.

***Before releasing the spring, care is to be taken to ensure that the ends of the spring rest in the cutouts of the top and bottom spring plates.***

The correct mounting position of the suspension springs can be determined by the printing on the springs; install them with the print upright.

Fit assembled shock absorber-spring assembly to the vehicle in reverse sequence of removal.

All rubber- mounted strut/ damper attachments must not be fully tightened until AFTER the suspension system is loaded (wheels on the ground). Other mounting fasteners (for example brackets) must be securely tightened BEFORE load is placed on the suspension system.

All self- locking nuts must be replaced. Tightening torques see list.

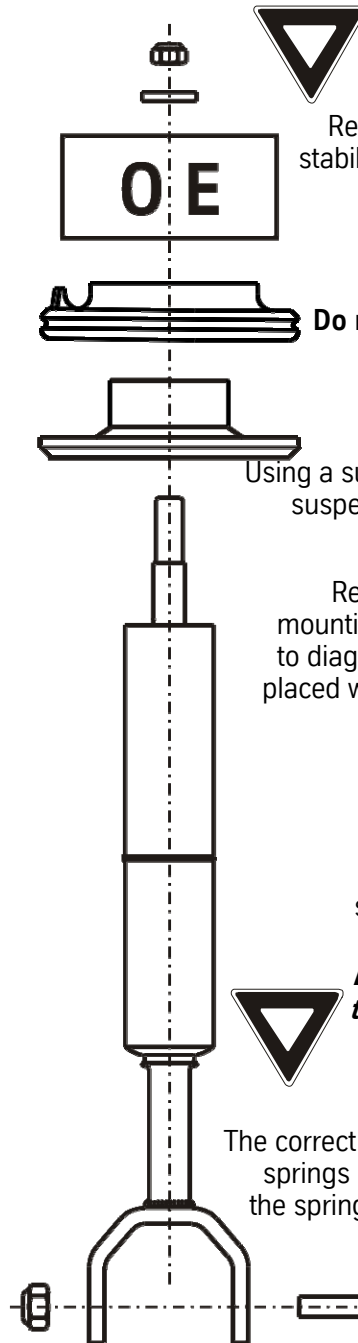

# E4-WM5-Y261A01

## MOUNTING INSTRUCTION



ALL DIAGRAMS ARE GENERALIZED  
AND NOT TO SCALE!  
BRACKETS, ETC. SPECIFIC TO  
STRUT ARE NOT SHOWN!

Fitting of plates with  
chamfer ( if exist )

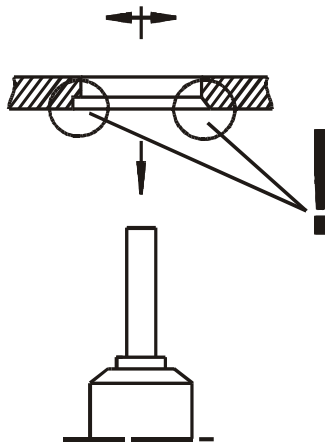

When fitting the spring plate ( 1 ) care must be taken to ensure that the circlip ring ( 2 ) is seated correctly!

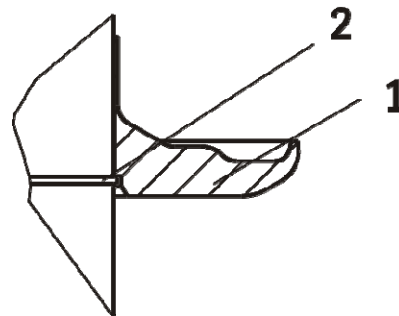

	M8	M 10	M 12	M 14	M 16	List
						Thread
	13	25	45	72	110	Torque Nm
	10	19	34	54	83	Torque ft lb

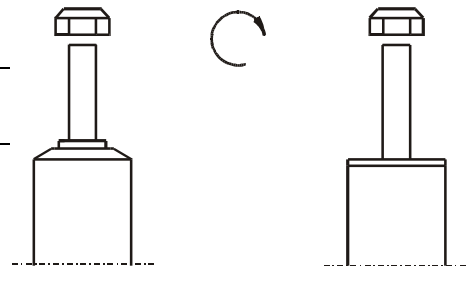

DO NOT USE AN IMPACT TOOL TO LOOSEN  
OR TIGHTEN FASTENERS DUE TO POSSIBLE  
DAMAGE TO THE PRODUCT.  
SELF- LOCKING NUTS MUST ONLY BE  
USED ONCE!