

# E4-WM5-Y178A00

## MOUNTING INSTRUCTIONS

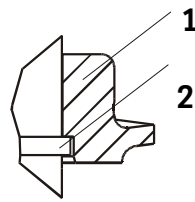

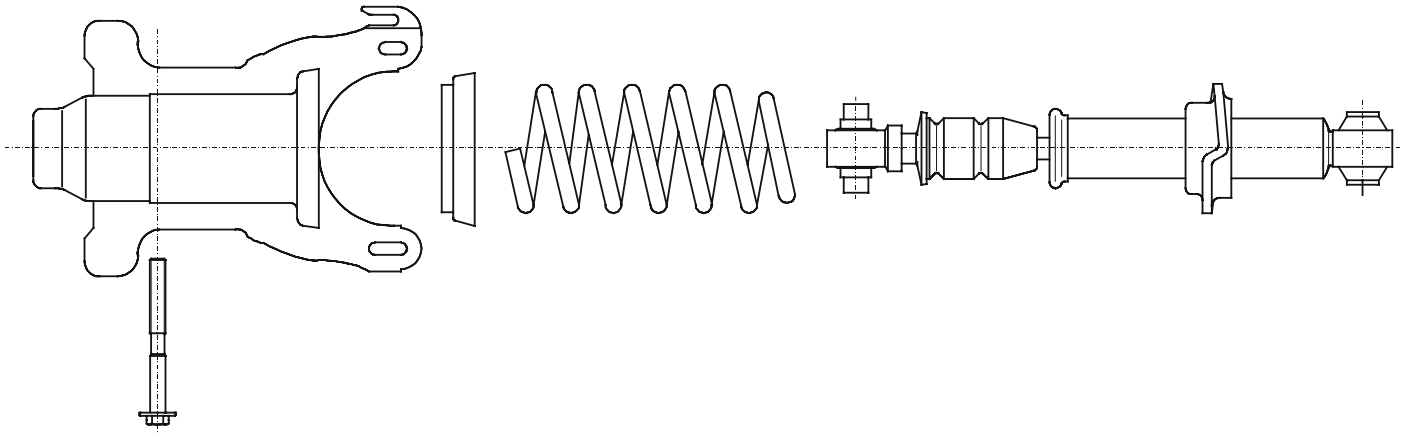

**ALL DRAWINGS ARE GENERALIZED!  
BRACKETS, ETC. SPECIFIC TO  
STRUT ARE NOT SHOWN!**

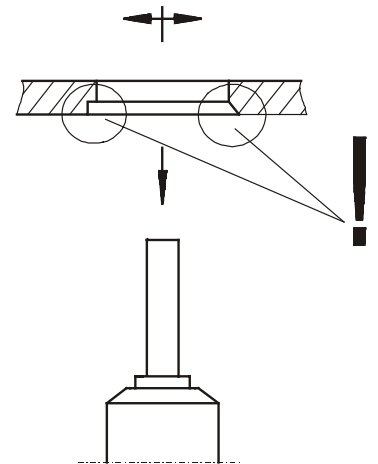

Montage von Tellern mit Fase/  
Ausdrehung (falls vorhanden)  
Fitting of plates with chamfer (if exist)

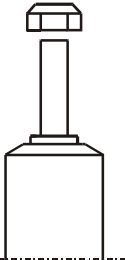

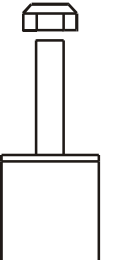
						<b>List</b>		
	<b>M 8</b>	<b>M 10</b>	<b>M 12</b>	<b>M 14</b>	<b>M 16</b>	<b>Thread</b>		
	13	25	45	72	110	<b>Torque Nm</b>		
	10	19	34	54	83	<b>Torque ft lb</b>		

# E4-WM5-Y178A00

## MOUNTING INSTRUCTIONS



### Remove

Place vehicle on a chassis hoist, lift it and remove wheels.



***The lower control arm must be supported by suitable means!***

Remove bottom mount.

Remove top fixing nut from support bearing.  
Do not remove center nut at this time!

Remove complete strut and clamp it in an appropriate strut vise.

Using a suitable spring compressor, compress suspension spring until tension on support bearing is released.

Release center nut and remove original mounting parts and coil spring. Please refer to diagram to identify which parts will be replaced with BILSTEIN- supplied components.

### Install

Assemble BILSTEIN and/ or original mounting parts, as well as the new BILSTEIN spring on the BILSTEIN strut in reverse sequence of removal.



***Before releasing the spring, care is to be taken to ensure that the ends of the spring rest in the cutouts of the top and bottom spring plates.***

The correct mounting position of the suspension springs can be determined by the printing on the springs; install them with the print upright.

Fit assembled BILSTEIN strut to the vehicle in reverse sequence to removal.