

# E4-WM5-Y120A00 MOUNTING INSTRUCTION



## Before installation please observe the following points:

- Read all information in this manual carefully.  
All suspension components are fitted and removed acc. to the manufacturer's specifications for installing and removal, if not otherwise required in these instructions.
- Check the product for all components before starting installation!
- Check that dimensions and fastening points are comparable between the original and BILSTEIN shock absorbers.
- Remove the negative battery pole.
- Directional references (left, right, front, rear) are always with reference to the driving direction.
- The tested vehicles are left- hand drive vehicles.

## After installation please observe the following points:

- After installing the suspension system, caster and camber must be checked and adjusted according to manufacturer's specifications. Check and reset load- dependent brake compensator and ABS system according to manufacturer's specifications.
- Check and adjust headlight setting.
- If the vehicle has been lowered, freedom of movement (clearance) for all wheel/ tire combinations must be checked.
- All rubber- mounted strut/ damper attachments must not be fully tightened until AFTER the suspension system is loaded (wheels on the ground). Other mounting fasteners (for example brackets) must be securely tightened BEFORE load is placed on the suspension system.
- Connect the negative battery pole.

All diagrams are generalized  
and not to scale!  
brackets, etc. specific to  
strut are not shown!

# E4-WM5-Y120A00 MOUNTING INSTRUCTION



## Removal

Place vehicle on a wheel- free car hoist,  
lift it and remove wheels.



***The lower control arm must be supported by suitable means!***

Loose and remove bottom mounting.

Remove top fixing nuts from support bearing.

**Do not remove central nut from shock absorber at this time!**

Remove complete shock absorber and clamp it in an appropriate strut vice.

Using a suitable spring compressor, compress suspension spring until support bearing is free to move.

Remove brake hose holder from original shock absorber. (For that purpose lay the shock absorber with the brake hose holder on the jaws of a vice and strike off the shock absorber.)



***Left-/ Right part must be observed. The holder must not be mixed.***

Remove nut and original mounting parts. Please refer to diagram to identify which parts will be replaced with BILSTEIN- supplied components.

The original spring pad must be reused!

## Installing

Strike on brake hose holder by using assembly tool (For that purpose lay the shock absorber, piston rod downwards, on the jaws of a vice and strike on the brake hose holder.)

Assemble BILSTEIN and/ or original mounting parts on the BILSTEIN shock absorber in reverse order as removal. Tenon of the brake hose holder must fit in gap of fork.



***Before releasing the spring, care is to be taken to ensure that the spring rest in the cut outs of top and bottom spring plate!***

Fit assembled BILSTEIN shock absorber to the vehicle in reverse order as removal.

# E4-WM5-Y120A00 MOUNTING INSTRUCTION



## list of torques

	M 8	M 10	M 12	M 14	M 16	Thread
	13	25	45	72	110	Torque Nm
	10	19	34	54	83	Torque ft lb

All diagrams are generalized  
and not to scale!  
Brackets, etc. specific to  
strut are not shown!

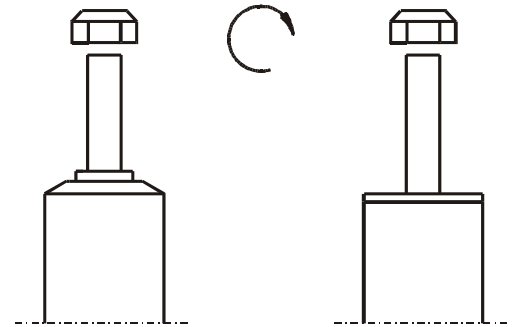

**Do not use an impact tool to loosen  
or tighten fasteners due to possible  
damage to the product.  
Self- locking nuts must only be  
used once!**

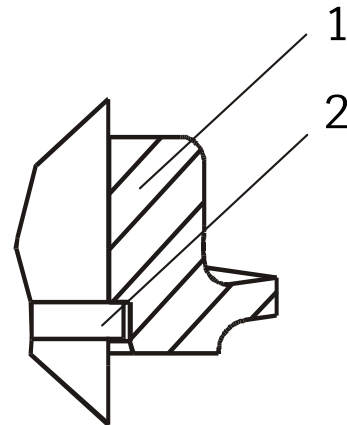

# E4-WM5-Y120A00 MOUNTING INSTRUCTION

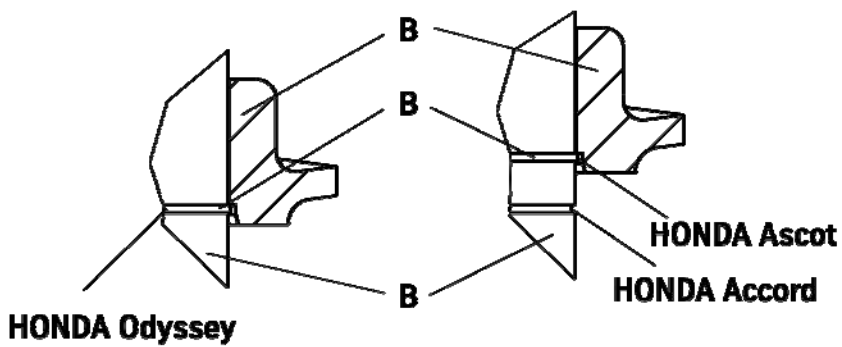
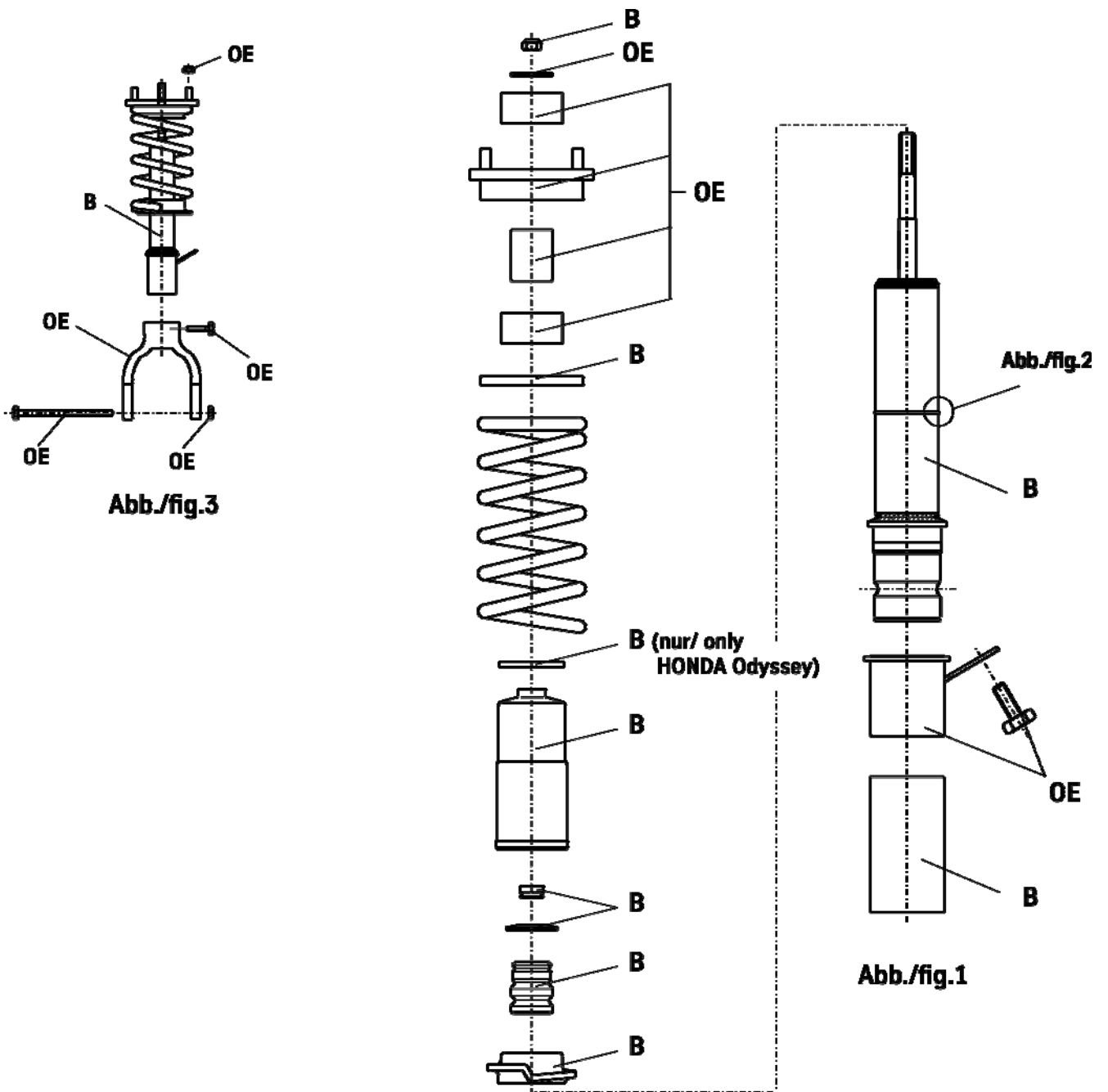

**Abb./fig.2**