

1. piston rod nut tightening torque 15 ft lb *B
2. support bearing assembly
3. pad
4. washer
5. dust cover *B
6. dust cover holder *B
7. plate *B
8. bump stop *B
9. spring
10. spring plate *B
11. BILSTEIN- shock absorber
12. brake hose holder
13. assembly tool *B
14. spring ring *B
15. nut torque 7,5 ft lb
16. clamping screw torque 33 ft lb
17. fork
18. nut torque 49 ft lb
19. screw

*B = mounting parts delivered by BILSTEIN

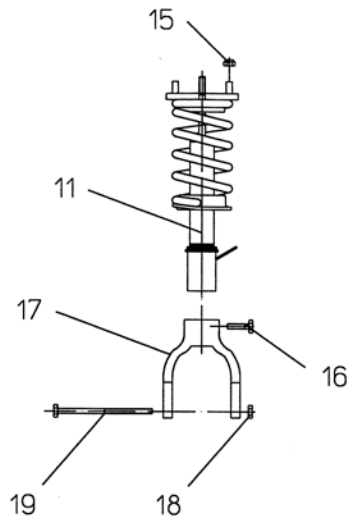


Abb./fig.3

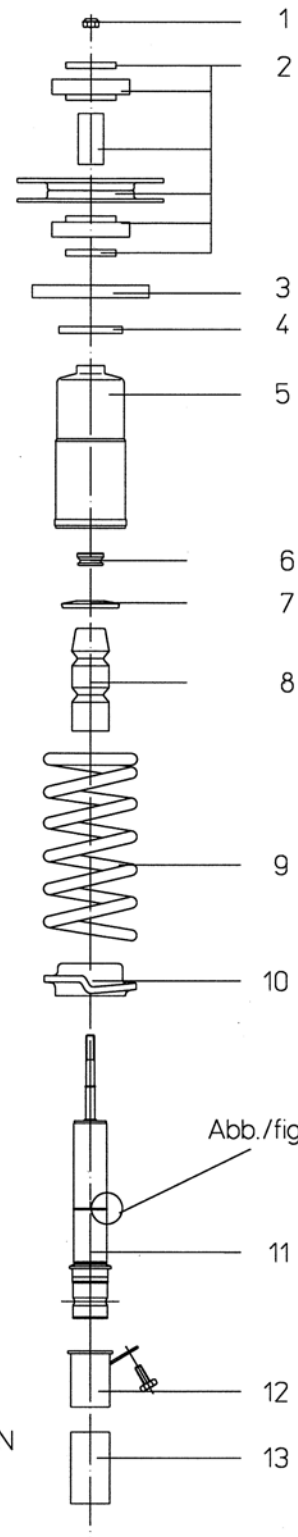


fig.1

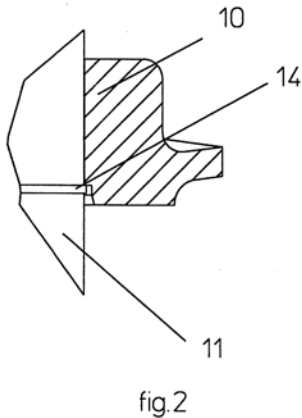


fig.2

ATTENTION!

(10) care must be taken to ensure that the spring ring (14) is seated correctly!

ATTENTION!

Do not damage the piston rod when knocking on the brake hose holder(12)!