



Contents:

- Certificate for multilink rear suspension only :

- AUDI A3 (8V) 2WD u. 4WD, S3, RS3 Hatchback, Cabriolet, Sportback B14/ B16 PSS10 -**
- SEAT Leon (5F) 2WD u. 4WD inkl. ST B14/ B16 PSS10 -**
- SKODA Octavia (5E) 2WD u. 4WD Saloon, Estate B14/ B16 PSS10 -**
- SKODA Superb (3T) 2WD u. 4WD Saloon, Estate B14/ B16 PSS10 -**
- VW Golf VII 2WD u. 4WD Hatchback (AU), Estate, Sportsvan (AUV) B14/ B16 PSS10 -**
- VW Touran (1T) B14/ B16 PSS10 -**
- VW Passat (B8) (3C) 2WD u. 4WD Saloon, Estate B14/ B16 PSS10 -**

- mounting instruction



**Before installation please observe
the following points:**

- Read all information in this manual carefully.
All suspension components are fitted and removed acc. to the manufacturer's specifications for fitting and removal, if not otherwise required in these instructions.

- Check that your vehicle type is listed in the certificate as being specified for this kit.

- Check the product for all components before starting installation!

- Check that dimensions and fastening points are comparable between the original and BILSTEIN shock absorbers.

- Directional references (left, right, front, rear) are always with reference to the driving direction.

- The test vehicles are left- hand drive cars.

- Disconnect the negative battery pole.

**After installation please observe
the following points:**

- Set the vehicle height by adjusting spring plates and lock nuts on the new dampers. Only use the supplied spanner wrenches.

- After installing the suspension system, caster and camber must be checked and adjusted according to manufacturer's specifications.
Check and reset load- dependent brake compensator and ABS system according to manufacturer's specifications.
Check and adjust headlight setting.

- Because the vehicle has been lowered,
Ground clearance for all wheel-/
tire- combinations must be checked.

- All rubber- mounted strut/ damper attachments must not be fully tightened until AFTER the suspension system is loaded (wheels on the ground). Other mounting fasteners (for example brackets) must be securely tightened BEFORE load is placed on the suspension system.

- Connect the negative battery pole again.

All diagrams are generalized
and not to scale!
Brackets, etc. specific to
strut are not shown!

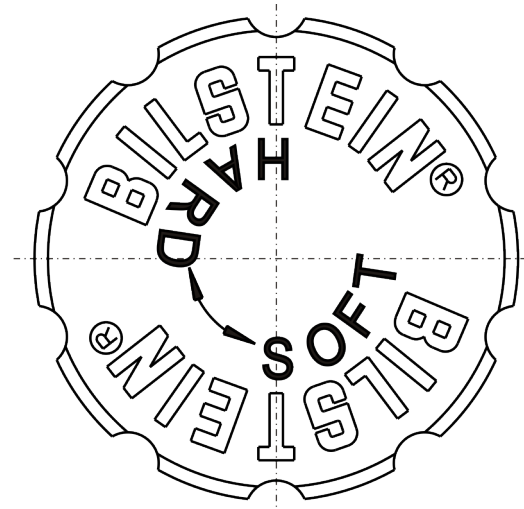
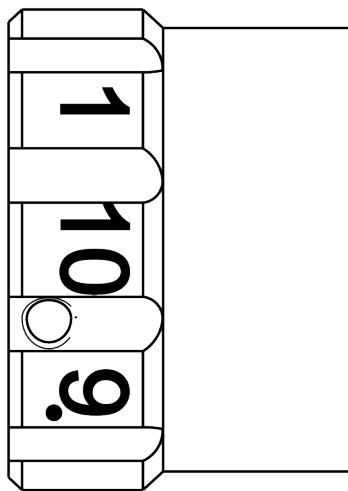

position **1** = **comfort**
 position **10** = **sport**

During the adjustment you will hear a positive „click“ at each position of the adjustment.

Instruction for the front and rear axle

Status of delivery is position **1**.

The adjusting element is located at the bottom edge of the strut.

Position **1** must aligned with the red mark.

Take care that the adjustment position is the same on both sides of vehicle (left/ right).

list of torques

M8	M 10	M 12	M 14	M 16	Thread
13	25	45	72	110	Torque Nm
10	19	34	54	83	Torque ft lb

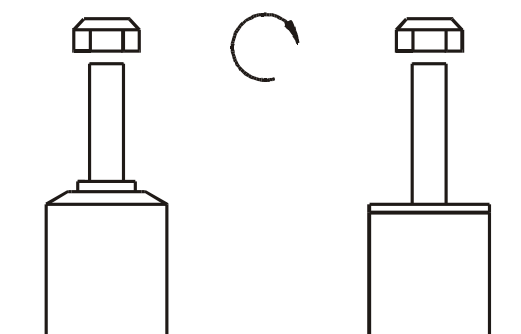

Do not use an impact tool to loosen or tighten fasteners due to possible damage to the product.
Self- locking nuts must only be used once!

Removal

Place vehicle on a wheel-free car hoist, lift it and remove wheels.

Vehicles equipped **with xenon headlight** the movable element of sensor for the headlamp levelling controller must removed before.



Pay attention that support wires of brake system are strain-free during removal. Stabilization by suitable means is demanded.

Remove bottom mount.

Remove top fixing nuts from support bearing.
Do not remove central nut at this time!

Remove complete strut and clamp it in an appropriate strut vice.

Using a suitable spring compressor, compress suspension spring until tension on support bearing is free to move.

Release centre nut and remove original mounting parts and coil spring. Please refer to diagram to identify which parts will be replaced with BILSTEIN- supplied components.

Installation

Assemble BILSTEIN and/ or original mounting parts, as well as the new BILSTEIN spring on the BILSTEIN strut in reverse order to removal.



IMPORTANT! Spring plates must not be adjusted outside the ranges specified in the certificate!

The correct mounting position of the suspension springs can be determined by the printing on the springs; install them with the print upright.



The top spring runout must be positioned at the highest point of spring plate slope (see page 17).

Do not reuse original dust cover and original- bumper, since BILSTEIN- strut has built in bump stop.

Fit assembled BILSTEIN strut to the vehicle in reverse order to removal.

OE = Original Equipment

B = Delivered by BILSTEIN

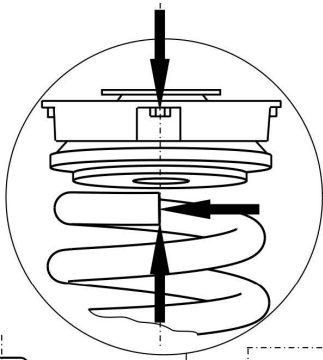

Attention
Pay attention to installing position of the spring!

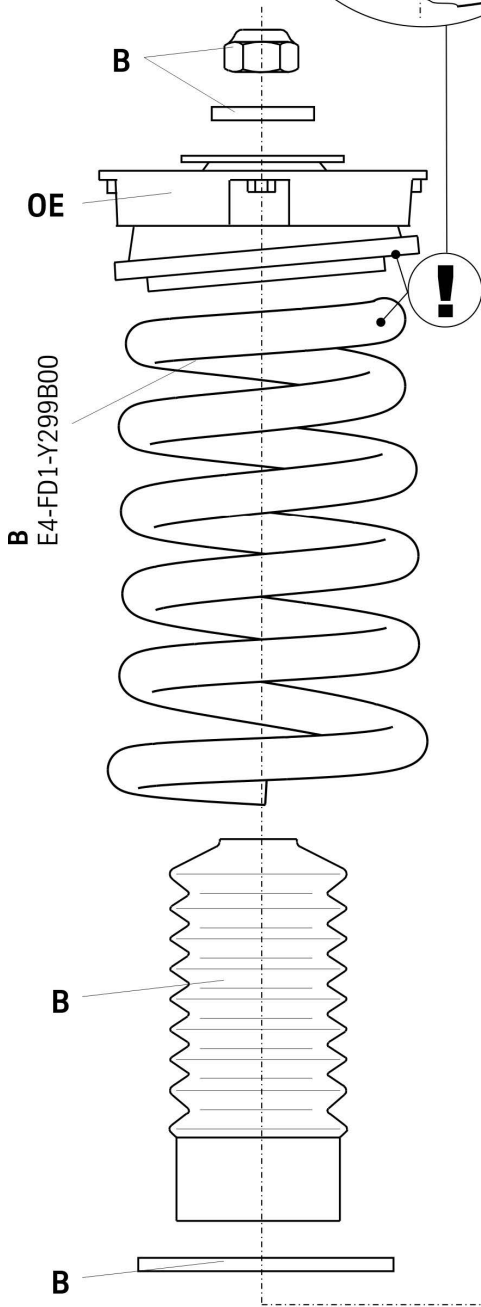

B16 PSS10

B14

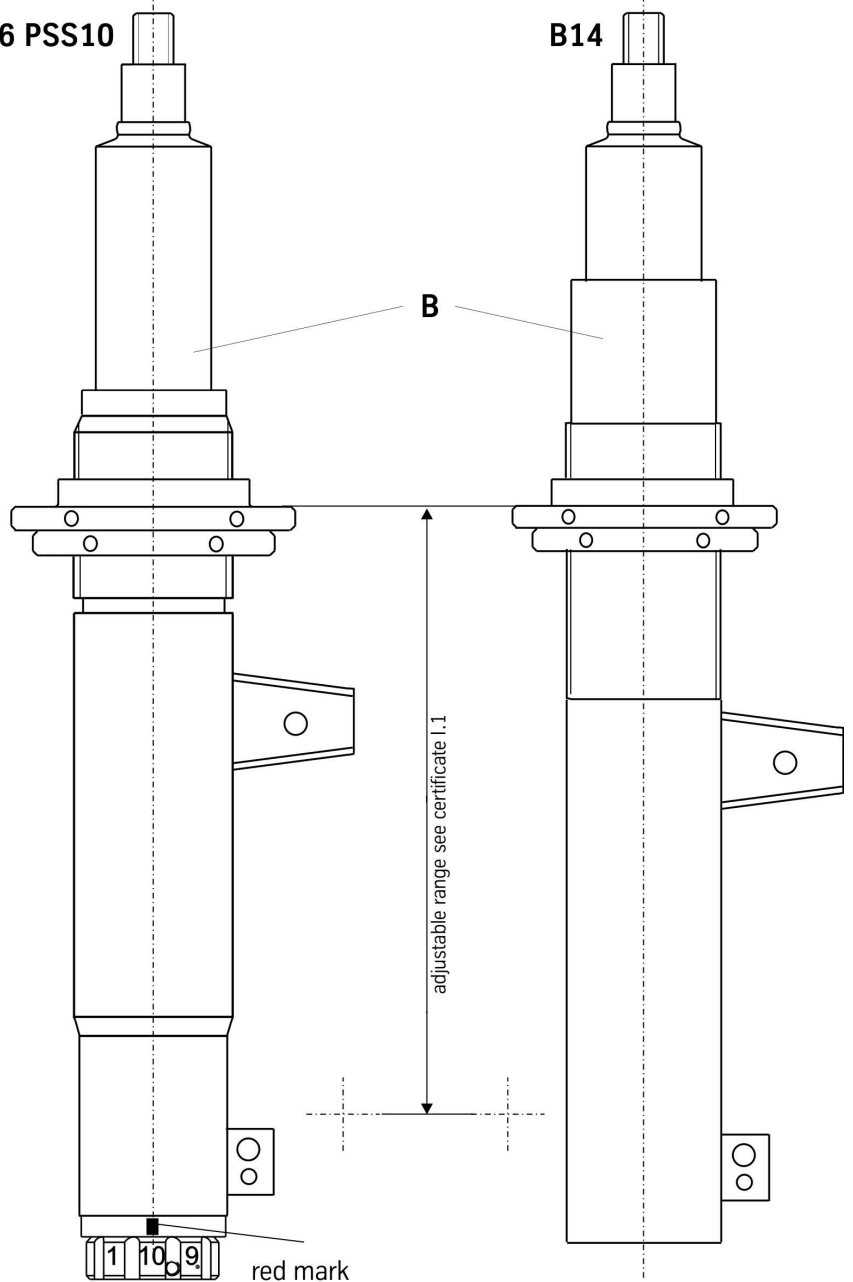



mounting instruction for rear axle

Removal

Place vehicle on a wheel-free car hoist, lift it and remove wheels.



Pay attention that support wires of brake system are strain-free during removal. Stabilization by suitable means is demanded.

Remove top and bottom fixing mount from support bearing.

Remove shock absorber and original mounting parts.

Installation

Fit BILSTEIN and/ or original mounting parts in BILSTEIN shock absorber in reverse order to removal.

Original dust cover and original bumper must reuse with B14 kit only.

Fit BILSTEIN shock absorber to the vehicle in reverse order to removal.

B16 PSS10

B14

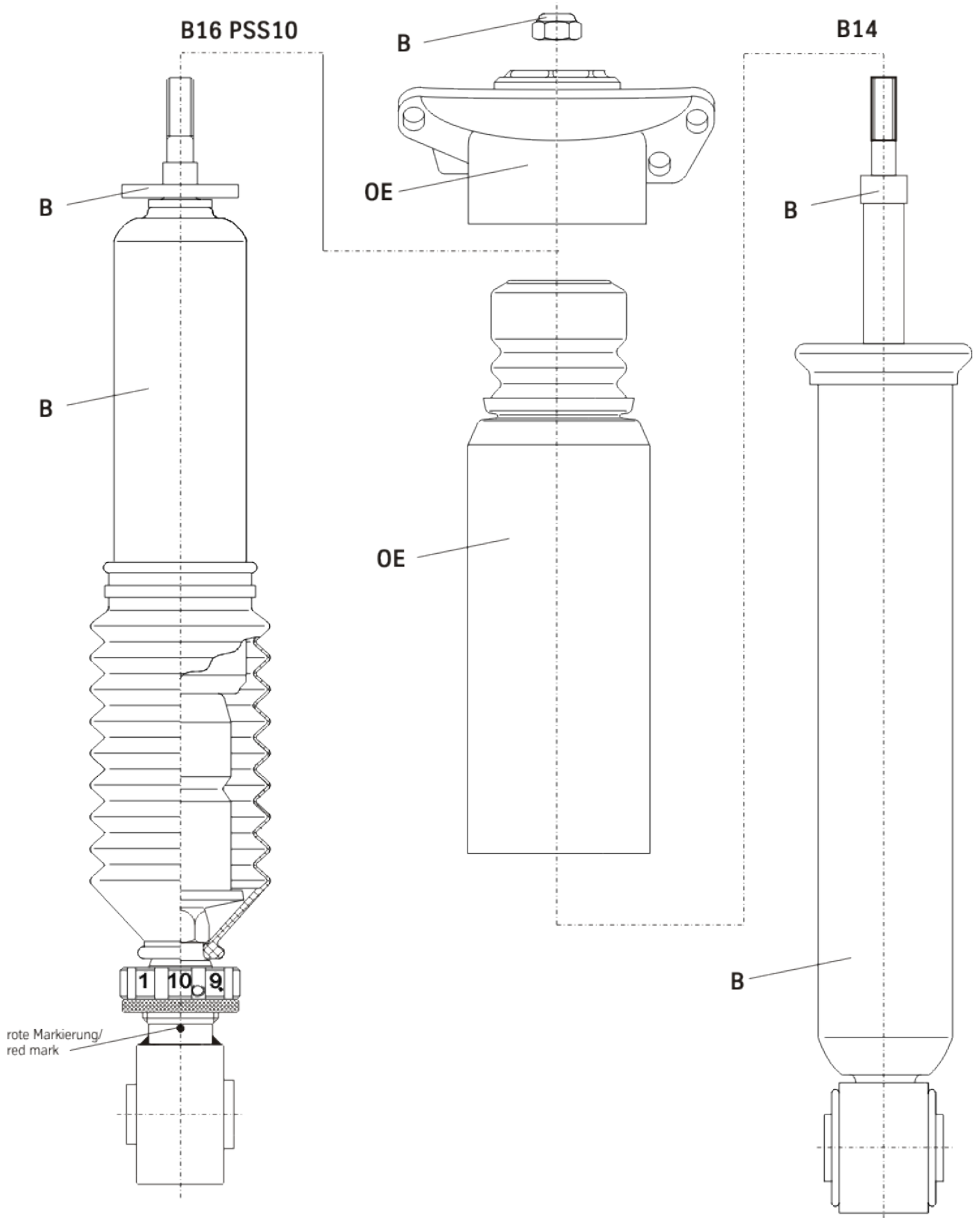

mounting instruction for rear axle height adjustment

OE = Original Equipment

B = Delivered by BILSTEIN

