

# E4-WM5-Y261A01

## MOUNTING INSTRUCTION



### Removal:

Place vehicle on a chassis hoist, lift it and remove wheels.

***The lower control arm must be supported by suitable means!***

Release bottom steering arm/ ABS line/ stabilizer/ brake hose and headlight range adjustment sensor (Xenon).

Remove bottom mount and top fixing nuts from support bearing.

**Do not remove centre nut at this time!**

Remove complete strut and clamp it in an appropriate strut vice.

Using a suitable spring compressor, compress suspension spring until tension on support bearing is released.

Release centre nut and remove original mounting parts and coil spring. Please refer to diagram to identify which parts will be replaced with BILSTEIN-supplied components.

### Installing:

Assemble BILSTEIN and/ or original mounting parts, as well as the new BILSTEIN spring on the BILSTEIN strut in reverse sequence of removal.

***Before releasing the spring, care is to be taken to ensure that the ends of the spring rest in the cutouts of the top and bottom spring plates.***

The correct mounting position of the suspension springs can be determined by the printing on the springs; install them with the print upright.

Fit assembled shock absorber-spring assembly to the vehicle in reverse sequence of removal.

All rubber-mounted strut/ damper attachments must not be fully tightened until AFTER the suspension system is loaded (wheels on the ground). Other mounting fasteners (for example brackets) must be securely tightened BEFORE load is placed on the suspension system.

All self-locking nuts must be replaced. Tightening torques see list.

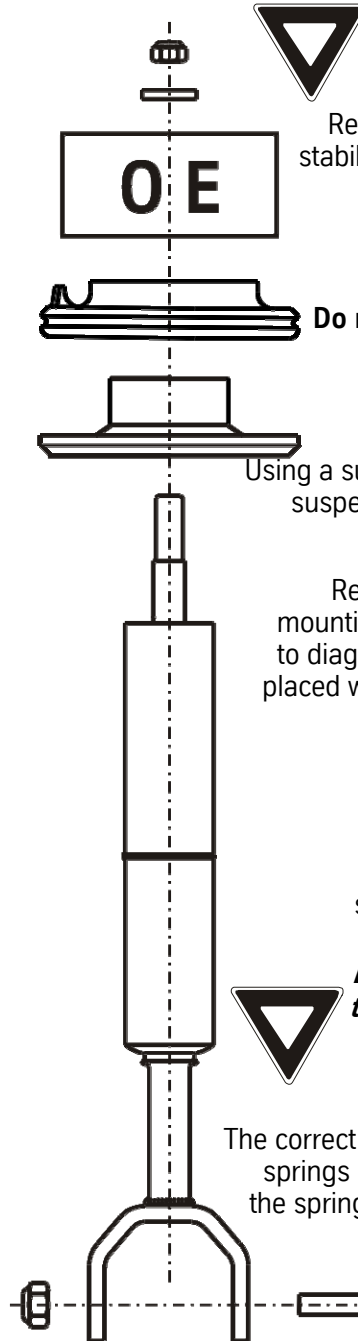

**MOUNTING INSTRUCTION**



ALL DIAGRAMS ARE GENERALIZED  
AND NOT TO SCALE!  
BRACKETS, ETC. SPECIFIC TO  
STRUT ARE NOT SHOWN!

Fitting of plates with  
chamfer ( if exist )

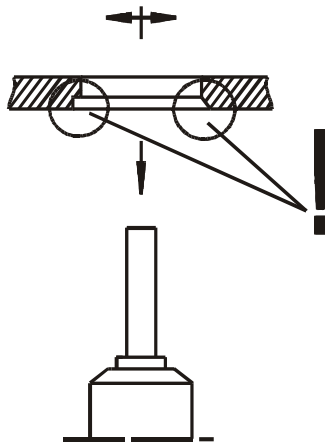

When fitting the spring plate ( 1 ) care must be taken to ensure that the circlip ring ( 2 ) is seated correctly!

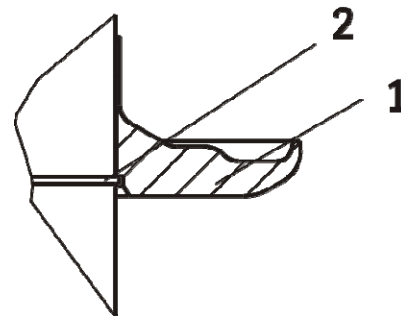

M8	M 10	M 12	M 14	M 16
13	25	45	72	110
10	19	34	54	83

**List**

**Thread**

**Torque  
Nm**

**Torque  
ft lb**

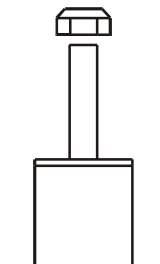
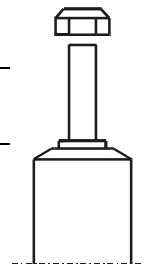

DO NOT USE AN IMPACT TOOL TO LOOSEN  
OR TIGHTEN FASTENERS DUE TO POSSIBLE  
DAMAGE TO THE PRODUCT.  
SELF- LOCKING NUTS MUST ONLY BE  
USED ONCE!

# E4-WM5-Y197A00

## MOUNTING INSTRUCTION



### **Before installation please observe the following points:**

- Read all information in this manual carefully.  
All suspension components are fitted and removed acc. to the manufacturer's specifications for installing and removal, if not otherwise required in these instructions.
- Check the product for all components before starting installation!
- Check that dimensions and fastening points are comparable between the original and BILSTEIN shock absorbers.
- Remove the negative battery pole.
- Directional references (left, right, front, rear) are always with reference to the driving direction.
- The tested vehicles are left- hand drive vehicles.

### **After installation please observe the following points:**

- After installing the suspension system, caster and camber must be checked and adjusted according to manufacturer's specifications.  
Check and reset load- dependent brake compensator and ABS system according to manufacturer's specifications.
  - Check and adjust headlight setting.
  - If the vehicle has been lowered, freedom of movement (clearance) for all wheel/ tire combinations must be checked.
  - All rubber- mounted strut/ damper attachments must not be fully tightened until AFTER the suspension system is loaded (wheels on the ground). Other mounting fasteners (for example brackets) must be securely tightened BEFORE load is placed on the suspension system.
  - Connect the negative battery pole.
- All diagrams are generalized and not to scale!  
Brackets, etc. specific to strut are not shown!

# E4-WM5-Y197A00 MOUNTING INSTRUCTION



## list of torques

M8	M 10	M 12	M 14	M 16	Thread
13	25	45	72	110	Torque Nm
10	19	34	54	83	Torque ft lb

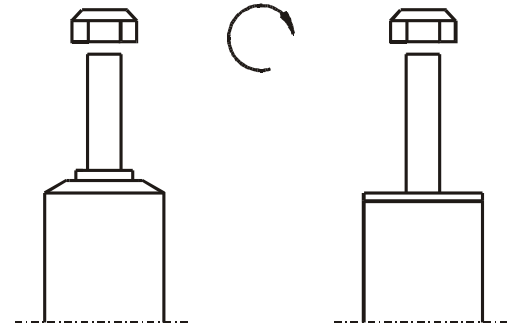

**Do not use an impact tool to loosen or tighten fasteners due to possible damage to the product. Self- locking nuts must only be used once!**

# E4-WM5-Y197A00

## MOUNTING INSTRUCTION



### Removal

Place vehicle on a wheel- free car hoist,  
lift it and remove wheel



**Pay attention that support wires  
of brake system are strain-free  
during removal. Stabilization by  
suitable means is demanded.**

Remove top and bottom mount.

Remove complete shock absorber  
and original mounting parts.

### Installation

Fit BILSTEIN and/ or original mounting parts  
on BILSTEIN shock absorber in reverse  
order to removal.

Fit BILSTEIN shock absorber to the vehicle  
in reverse order to removal.

# E4-WM5-Y197A00 MOUNTING INSTRUCTION

**OE** = Original Anbauteile  
Original Equipment



**B** = BILSTEIN Lieferumfang  
Delivered by BILSTEIN

