

E4-WM5-Y180A09

MOUNTING INSTRUCTION



Before installation please observe the following points:

- Read all information in this manual carefully.
All suspension components are fitted and removed acc. to the manufacturer's specifications for fitting and removing, if not otherwise required in these instructions.
- Check the product for all components before starting installation!
- Check that dimensions and fastening points are comparable between the original and BILSTEIN shock absorbers.
- Remove the negative battery pole.
- Directional references (left, right, front, rear) are always with reference to the driving direction.
- The tested vehicles are left- hand drive vehicles.

After installation please observe the following points:

- After installing the suspension system, caster and camber must be checked and adjusted according to manufacturer's specifications.
Check and reset load- dependent brake compensator and ABS system according to manufacturer's specifications.
- Check and adjust headlight aim.
- Because the vehicle has been lowered, freedom of movement for all wheel-/ tire- combinations must be checked.
- All rubber- mounted strut/ damper attachments must not be fully tightened until AFTER the suspension system is loaded (wheels on the ground). Other mounting fasteners (for example brackets) must be securely tightened BEFORE load is placed on the suspension system.
- Connect the negative battery pole.

All diagrams are generalized and not to scale!
Brackets, etc. specific to strut are not shown!

Removal

Place vehicle on a wheel-free car hoist, lift it and remove wheels.



The lower control arm must be supported by suitable means!

Remove bottom mount.

If necessary release brake hose/ brake hose holder/ stabilizer/ ABS- hose and/ or swing- support at strut. At support suspension arm, screw on top, inside must be released a little.

Remove top fixing nuts from support bearing.
Do not remove central nut at this time!

Remove complete strut and clamp it in an appropriate strut vice.

Using a suitable spring compressor, compress suspension spring until tension on support bearing is free to move.

Fit original/ BILSTEIN mounting parts on strut in reverse order as removal, except for bump stop, since BILSTEIN- strut has built in bump stop. Please refer to diagram to identify which parts will be replaced with BILSTEIN- supplied components also. If there is no dust cover delivered by BILSTEIN, the original one is to be reused.
ATTENTION: Some models are equipped with plastic- dustcover cap also. **Do not** reuse this cap!

Installation

Assemble BILSTEIN and/ or original mounting parts, as well as the new BILSTEIN spring, if been used, on the BILSTEIN strut in reverse order as removal.



Before releasing the spring, care is to be taken to ensure that the spring rest in the cut outs of top and bottom spring plate!

The correct mounting position of the suspension springs can be determined by the printing on the springs; install them with the print upright.

Fit assembled BILSTEIN strut to the vehicle in reverse order as removal.

E4-WM5-Y180A09 MOUNTING INSTRUCTION



Tabelle Anzugsmomente

M8	M 10	M 12	M 14	M 16	Thread
13	25	45	72	110	Torque Nm
10	19	34	54	83	Torque ft lb

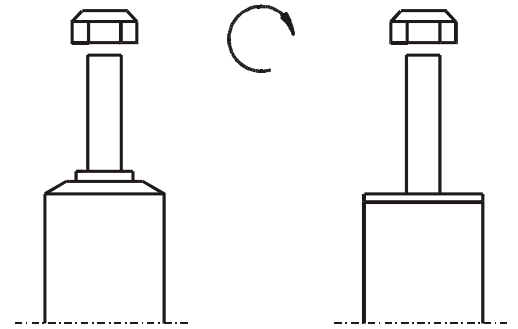

Do not use an impact tool to loosen or tighten fasteners due to possible damage to the product.
Self- locking nuts must only be used once!

E4-WM5-Y180A09 MOUNTING INSTRUCTION



front axle left/ right

OE= Original Anbauteile
Original Equipment

B= BILSTEIN Lieferumfang
Delivered by BILSTEIN

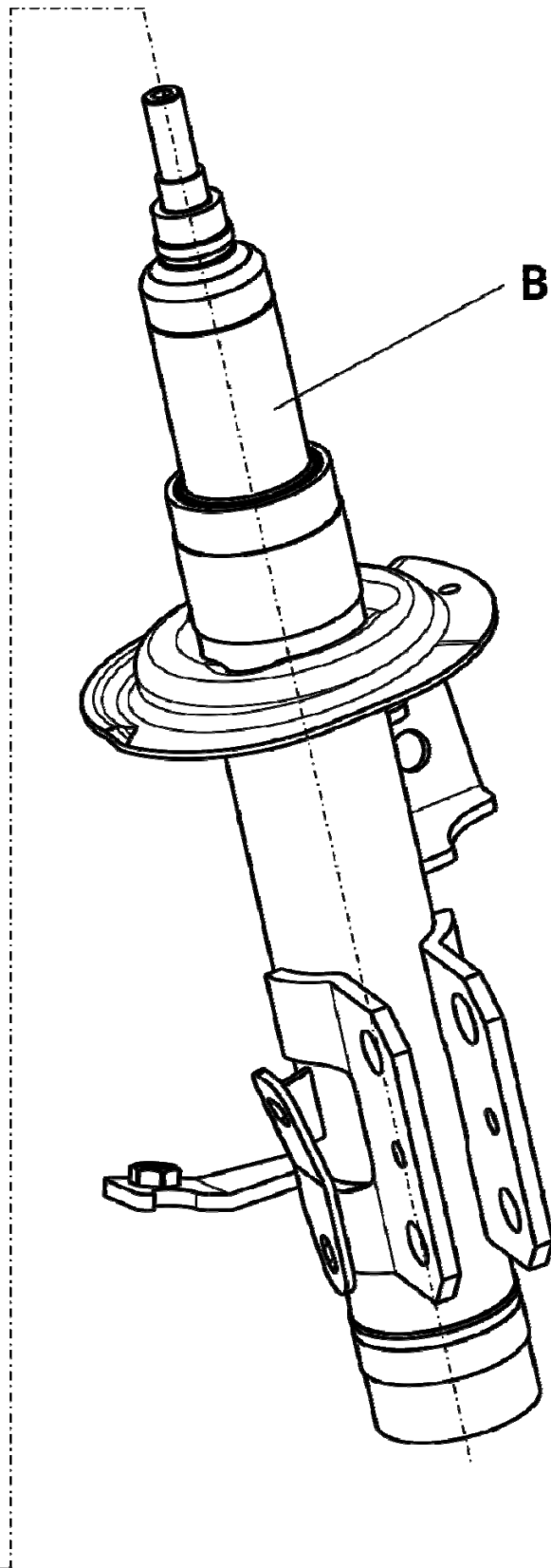
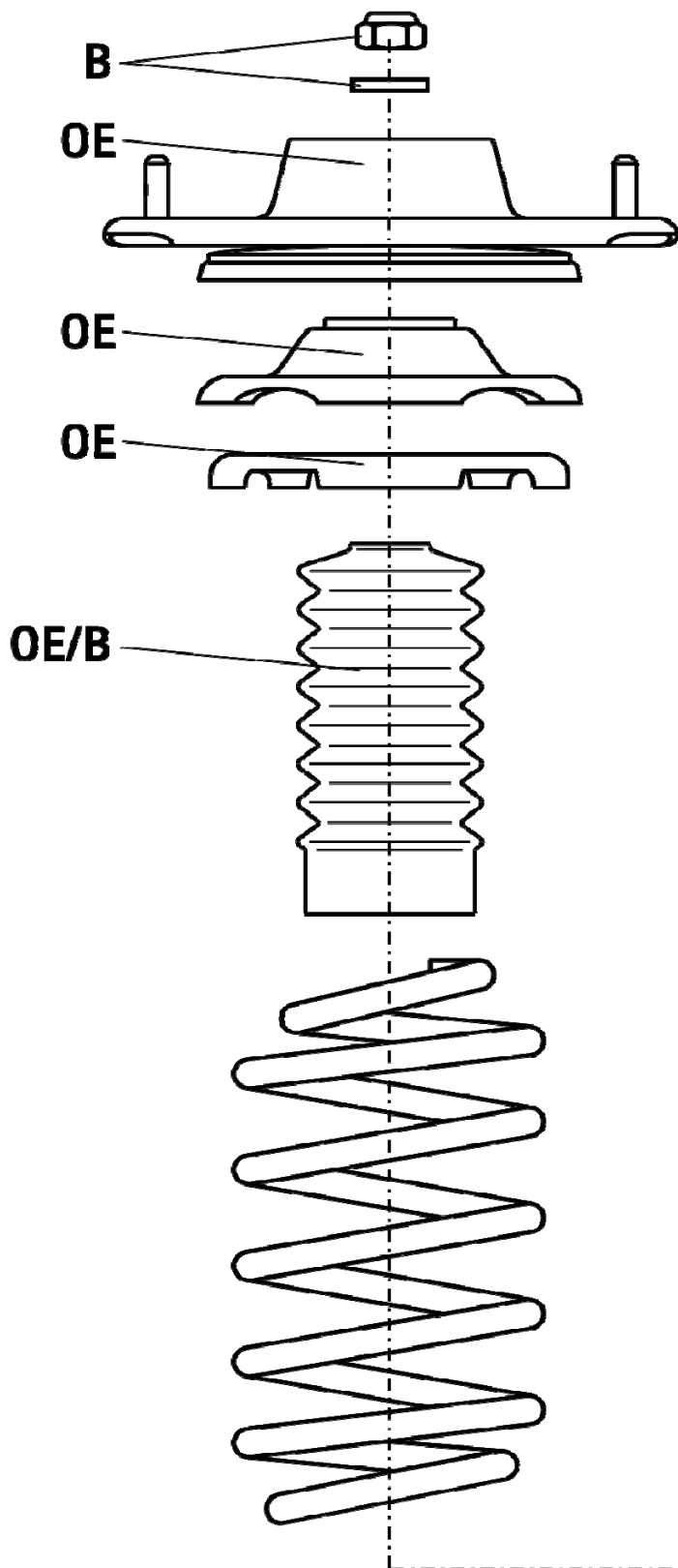

E4-WM5-Y437A00

MOUNTING INSTRUCTION



Before installation please observe the following points:

- Read all information in this manual carefully.
All suspension components are fitted and removed acc. to the manufacturer's specifications for installing and removal, if not otherwise required in these instructions.
- Check the product for all components before starting installation!
- Check that dimensions and fastening points are comparable between the original and BILSTEIN shock absorbers.
- Remove the negative battery pole.
- Directional references (left, right, front, rear) are always with reference to the driving direction.
- The tested vehicles are left- hand drive vehicles.

After installation please observe the following points:

- After installing the suspension system, caster and camber must be checked and adjusted according to manufacturer's specifications.
Check and reset load- dependent brake compensator and ABS system according to manufacturer's specifications.
- Check and adjust headlight setting.
- If the vehicle has been lowered, freedom of movement (clearance) for all wheel/ tire combinations must be checked.
- All rubber- mounted strut/ damper attachments must not be fully tightened until AFTER the suspension system is loaded (wheels on the ground). Other mounting fasteners (for example brackets) must be securely tightened BEFORE load is placed on the suspension system.
- Connect the negative battery pole.

All diagrams are generalized
and not to scale!
brackets, etc. specific to
strut are not shown!



MOUNTING INSTRUCTION

Removal

Place vehicle on a wheel- free car hoist,
lift it and remove wheels.



The lower control arm must be supported by suitable means!

Remove bottom mounting.

Remove top fixing nuts from support bearing.
Do not remove central nut at this time!

Detach cable connection.

Remove complete shock absorber and
clamp it in an appropriate strut vice.

Using a suitable spring compressor,
compress suspension spring until support
bearing is free to move.

Remove nut and original mounting parts.
Please refer to diagram to identify which parts
will be replaced with BILSTEIN- supplied
components. Check and document position of
the spring plate at the original shock absorber
for installing of BILSTEIN shock absorber.

The original spring pad, bumper and dust
cover must be reused!

Installing

Assemble BILSTEIN and/ or original mounting
parts on the BILSTEIN shock absorber in
reverse order as removal.

Press the original bumper with little pressure
on the fitting device (sleeve) delivered by
BILSTEIN.



Before releasing the spring, care is to be taken to ensure that the spring rest in the cut outs of top and bottom spring plate!

Fit assembled BILSTEIN shock absorber to
the vehicle in reverse order as removal.

E4-WM5-Y437A00 MOUNTING INSTRUCTION



All diagrams are generalized
and not to scale!
Brackets, etc. specific to
strut are not shown!

list of torques

M8	M 10	M 12	M 14	M 16	Thread
13	25	45	72	110	Torque Nm
10	19	34	54	83	Torque ft lb

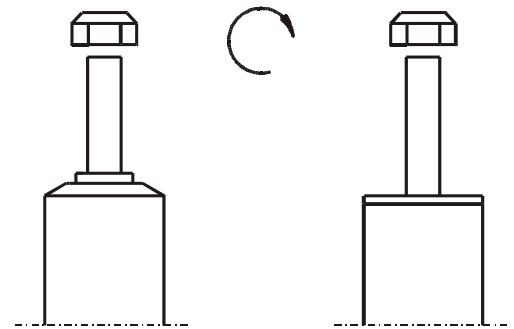

**Do not use an impact tool to loosen
or tighten fasteners due to possible
damage to the product.
Self- locking nuts must only be
used once!**

E4-WM5-Y437A00 MOUNTING INSTRUCTION



OE = Original Anbauteile
Original Equipment

B = BILSTEIN Lieferumfang
Delivered by BILSTEIN

