

E4-WM5-Y335A00

MOUNTING INSTRUCTION

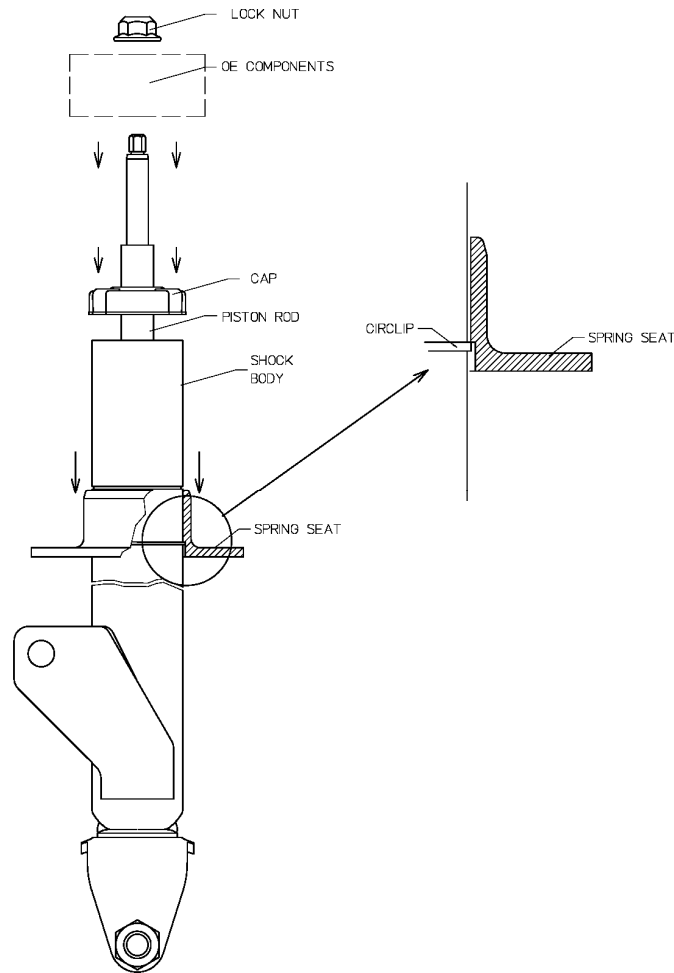

IMPORTANT!

Installation of [shock absorbers](#) requires special tools and expert knowledge. Accordingly, installation of all BILSTEIN products must be performed by a qualified suspension specialist.

Always use a chassis hoist for the installation of BILSTEIN products and make certain that the raised vehicle is securely attached to the hoist and/or supported to prevent the vehicle from slipping, falling, or moving during the installation process.

If you choose to install any BILSTEIN product without the necessary special tools, expertise or chassis hoist, you may subject yourself to the risk of serious bodily injury or death. If you elect not to use a chassis hoist, at least make sure the vehicle is on level ground, that all tires on the ground during installation are blocked to prevent movement, and that adequately secured safety stands (jack stands) are used to support the chassis. **NEVER** get under the vehicle until you have checked to make sure all of these steps are performed.

CAUTION!!

Before disassembling the front suspension, refer to the vehicle manufacturer's Service Manual for proper procedures. The coil spring is preloaded and must be compressed with a spring compressor to release load before the upper mount is disassembled. Failure to follow the vehicle manufacturer's procedures may cause serious injury or death, and may damage the vehicle.

Instructions for assembly of shock absorber module:

1. Install the Spring Seat onto the shock body as shown. Ensure that the groove inside the Spring Seat fits over the Circlip on the shock body (see detail).
2. Tap the Cap (supplied) squarely onto the top of the shock body. Use a rubber mallet or similar tool to prevent damaging the chromed piston rod. Make sure the cap is fully seated.
3. Re-install coil spring and all original parts in reverse order of removal.
4. Install new lock nut and tighten to 83 Nm (61 lb/ft).