

E4-WM5-Y261A01

MOUNTING INSTRUCTION



Removal:

Place vehicle on a chassis hoist, lift it and remove wheels.

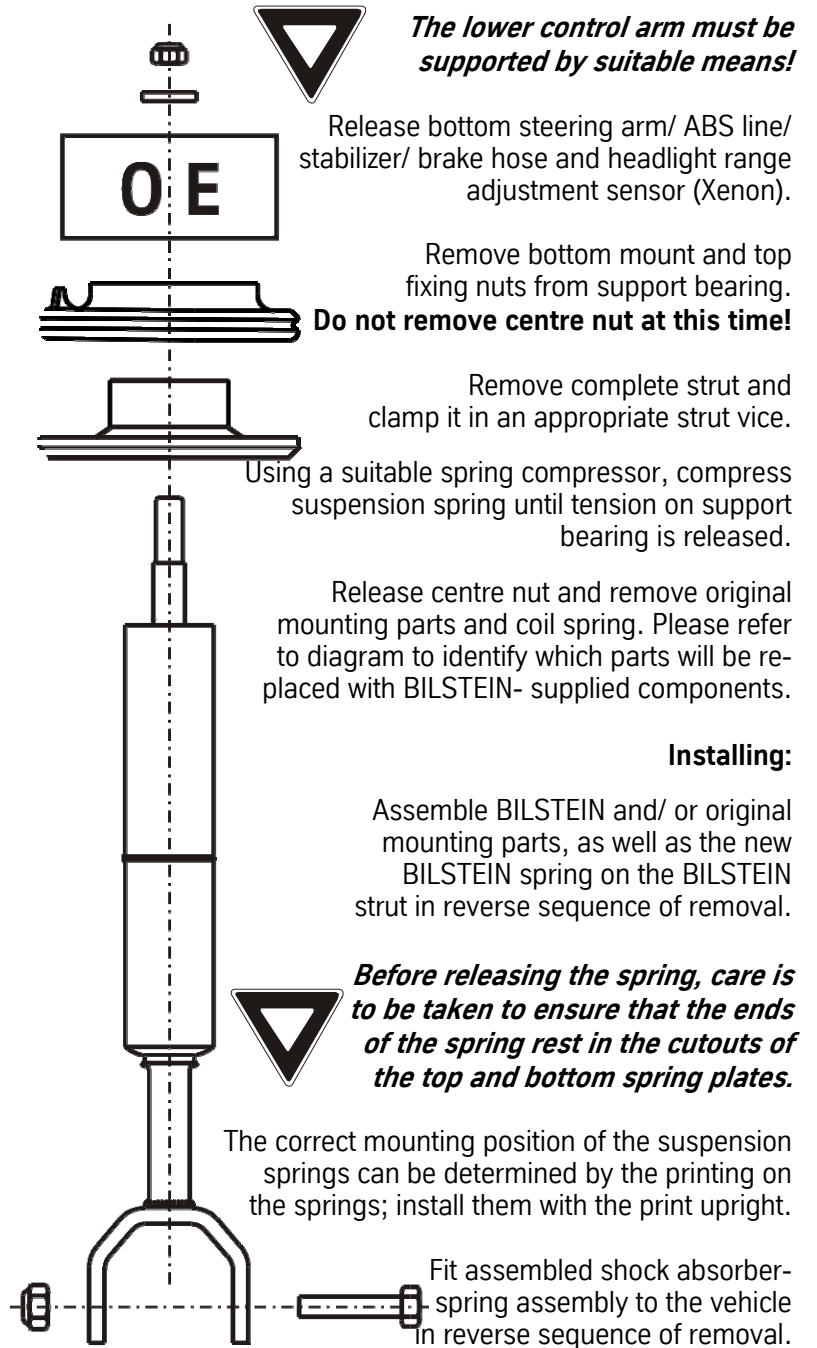

All rubber- mounted strut/ damper attachments must not be fully tightened until AFTER the suspension system is loaded (wheels on the ground). Other mounting fasteners (for example brackets) must be securely tightened BEFORE load is placed on the suspension system.

All self- locking nuts must be replaced.
Tightening torques see list.



ALL DIAGRAMS ARE GENERALIZED
AND NOT TO SCALE!
BRACKETS, ETC. SPECIFIC TO
STRUT ARE NOT SHOWN!

Fitting of plates with
chamfer (if exist)

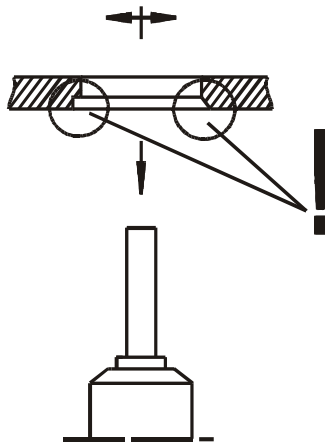

When fitting the spring plate (1) care must be taken to ensure that the circlip ring (2) is seated correctly!

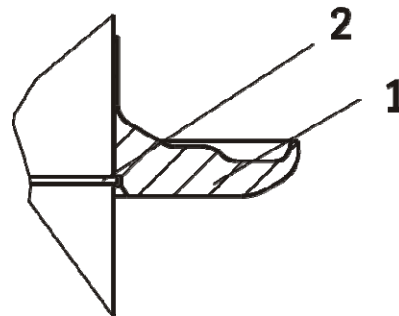

Tabelle

M 8	M 10	M 12	M 14	M 16
13	25	45	72	110
10	19	34	54	83

List

Thread

Torque
Nm

Torque
ft lb

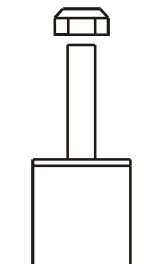
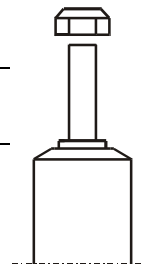

DO NOT USE AN IMPACT TOOL TO LOOSEN
OR TIGHTEN FASTENERS DUE TO POSSIBLE
DAMAGE TO THE PRODUCT.
SELF- LOCKING NUTS MUST ONLY BE
USED ONCE!

E4-WM5-Y197A00 MOUNTING INSTRUCTION



Before installation please observe the following points:

- Read all information in this manual carefully.
All suspension components are fitted and removed acc. to the manufacturer's specifications for installing and removal, if not otherwise required in these instructions.
- Check the product for all components before starting installation!
- Check that dimensions and fastening points are comparable between the original and BILSTEIN shock absorbers.
- Remove the negative battery pole.
- Directional references (left, right, front, rear) are always with reference to the driving direction.
- The tested vehicles are left- hand drive vehicles.

After installation please observe the following points:

- After installing the suspension system, caster and camber must be checked and adjusted according to manufacturer's specifications.
Check and reset load- dependent brake compensator and ABS system according to manufacturer's specifications.
 - Check and adjust headlight setting.
 - If the vehicle has been lowered, freedom of movement (clearance) for all wheel/ tire combinations must be checked.
 - All rubber- mounted strut/ damper attachments must not be fully tightened until AFTER the suspension system is loaded (wheels on the ground). Other mounting fasteners (for example brackets) must be securely tightened BEFORE load is placed on the suspension system.
 - Connect the negative battery pole.
- All diagrams are generalized
and not to scale!
Brackets, etc. specific to
strut are not shown!

E4-WM5-Y197A00 MOUNTING INSTRUCTION



list of torques

M8	M 10	M 12	M 14	M 16	Thread
13	25	45	72	110	Torque Nm
10	19	34	54	83	Torque ft lb

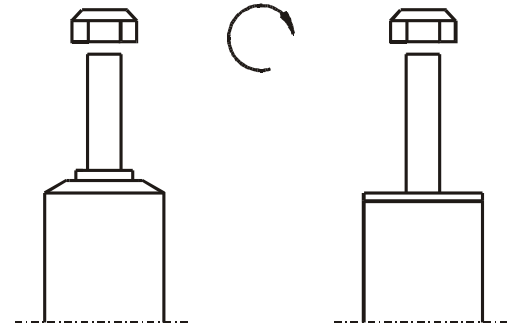

Do not use an impact tool to loosen or tighten fasteners due to possible damage to the product. Self- locking nuts must only be used once!

E4-WM5-Y197A00

MOUNTING INSTRUCTION



Removal

Place vehicle on a wheel- free car hoist,
lift it and remove wheel



**Pay attention that support wires
of brake system are strain-free
during removal. Stabilization by
suitable means is demanded.**

Remove top and bottom mount.

Remove complete shock absorber
and original mounting parts.

Installation

Fit BILSTEIN and/ or original mounting parts
on BILSTEIN shock absorber in reverse
order to removal.

Fit BILSTEIN shock absorber to the vehicle
in reverse order to removal.

E4-WM5-Y197A00 MOUNTING INSTRUCTION

OE = Original Anbauteile
Original Equipment



B = BILSTEIN Lieferumfang
Delivered by BILSTEIN

