



MOUNTING INSTRUCTION E4-WM5-Y133A00

ATTENTION!

This BILSTEIN shock absorber must not be modified. It may be used for the application stated in the typelist only. If in doubt, call us before fitment.

Removal:

- Place vehicle on a wheelless lifting platform.
- Release upper shock mount.
- Lift vehicle in order to relax spring.
- Release bottom shock mount.
- Remove shock and spring.

Fitment:

- Fix spring plate (4) at BILSTEIN shock absorber (3).
- Reuse original mounting parts.
- Fitting to the vehicle in reverse sequence to renewed.
- All self- locking nuts must be replaced.
- Finally tighten the bottom fixing bolt when the vehicle is standing on the ground.

Attention: After fitting the shock absorbers, the caster and chamber must be checked and/or adjusted according to the vehicle producer's handbook. Check and reset brake power (load dependant) in accordance with the manufacturer's instructions. Also, the headlight adjustment has to be checked/ or adjusted.

EINBAUANLEITUNG/MOUNTING INSTRUCTION E4-WM5-Y133A00

1. nut torque 11 ft lb *B
2. washer
3. nut torque 16 ft lb
4. support bearing
5. rubber pad
6. helical spring
7. rubber pad
8. cap
9. bumper
10. dust cover
11. top cap *B
12. BILSTEIN shock absorber
13. spring plate *B
14. spring ring
15. hexagon bolt torque 93 ft lb

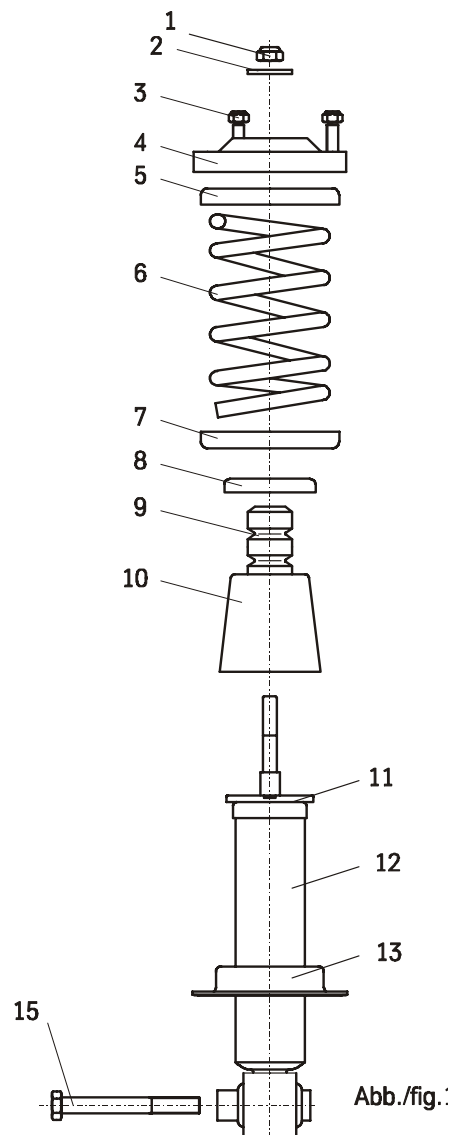

mounting parts delivered by BILSTEIN

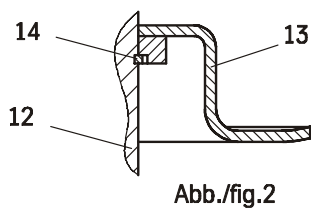

ACHTUNG/ATTENTION!
 Bei der Montage des Federtellers (13) ist auf korrekten Sitz des Sprengringes (14) zu achten!
 When fitting the spring plate (13) care must be taken to ensure that the spring ring (14) is seated correctly!

