

# E4-WM5-Y132A00

## MOUNTING INSTRUCTION

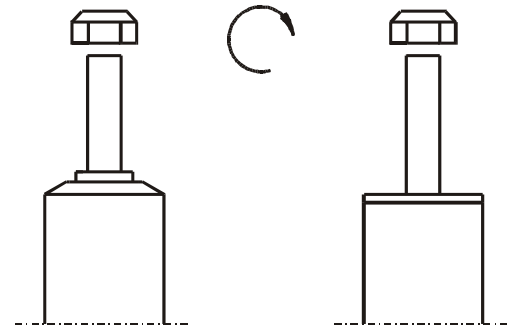

	M8	M 10	M 12	M 14	M 16	Thread
	13	25	45	72	110	Torque Nm
	10	19	34	54	83	Torque ft lb



DO NOT USE IMPACT TOOLS FOR LOOSENING OR TIGHTENING FASTENERS, BECAUSE THIS MAY DESTROY THE THREADS. SELF- LOCKING NUTS MUST ONLY BE **USED ONCE!**

1. BILSTEIN shock absorber with original spring
2. BILSTEIN shock absorber with BILSTEIN spring
3. Original shock absorber with BILSTEIN spring

### Remove

Place vehicle on a chassis hoist, lift it, remove wheels and wheelhouse liner.



ALL RUBBER- MOUNTED STRUT/ DAMPER ATTACHMENTS MUST NOT BE FULLY TIGHTENED UNTIL AFTER THE SUSPENSION SYSTEM IS LOADED (WHEELS ON THE GROUND). OTHER MOUNTING FASTENERS (FOR EXAMPLE BRACKETS) MUST BE SECURELY TIGHTENED BEFORE LOAD IS PLACED ON THE SUSPENSION SYSTEM.

***The lower control arm must be supported by suitable means!***

Remove top and bottom fixing mount from support bearing.

Remove shock absorber and original mounting parts.

### Install

Fit disc (X) and sleeve (Y/ Z), delivered by BILSTEIN,

Fit BILSTEIN and/ or original mounting parts in BILSTEIN shock absorber in reverse sequence of removal.

Fit BILSTEIN shock absorber to the vehicle in reverse sequence of removal.

**E4-WM5-Y132A00**  
**MOUNTING INSTRUCTION**



ALL DIAGRAMS ARE GENERALIZED  
AND NOT TO SCALE!  
BRACKETS, ETC. SPECIFIC TO  
STRUT ARE NOT SHOWN!

**BMW E30/ E36 compact/ E46/ Z3 M- roadster (M85)/ Z4 (Z85)**

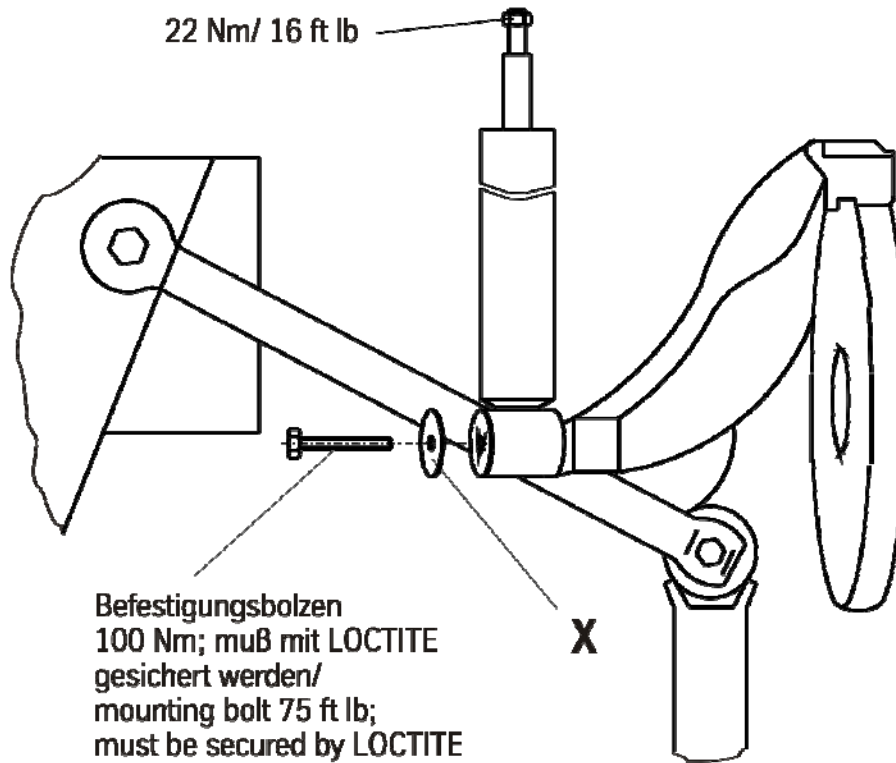

**BMW Z3/ Z3 Coupe 2,8l**

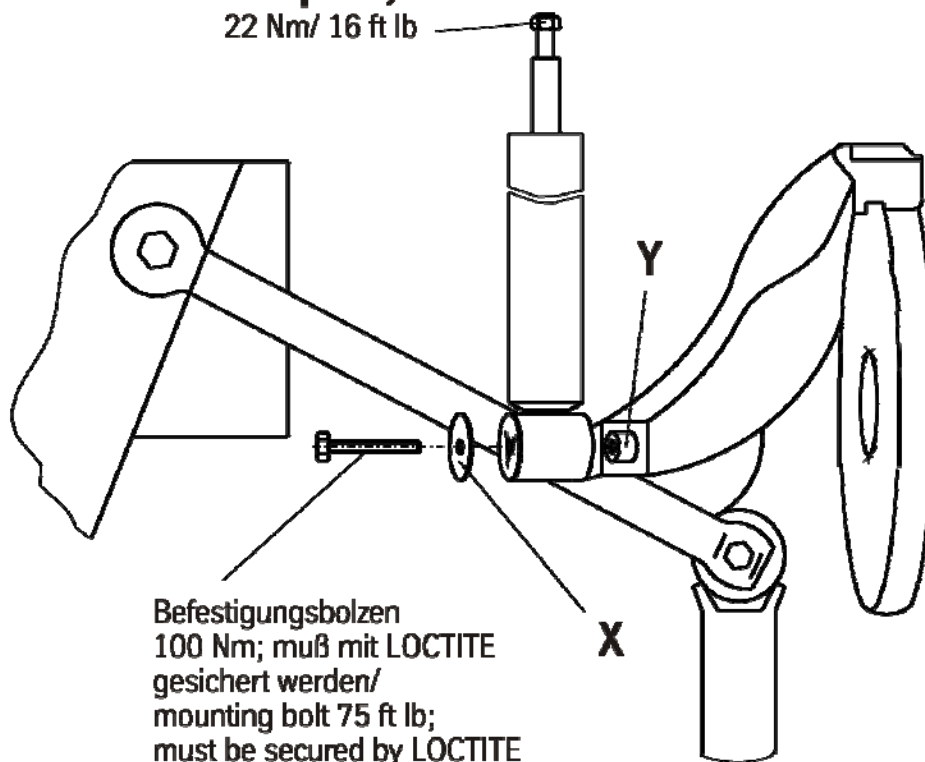

# E4-WM5-Y132A00 MOUNTING INSTRUCTION



## BMW E46 M3/ Z4 M- coupe/ roadster (M85)

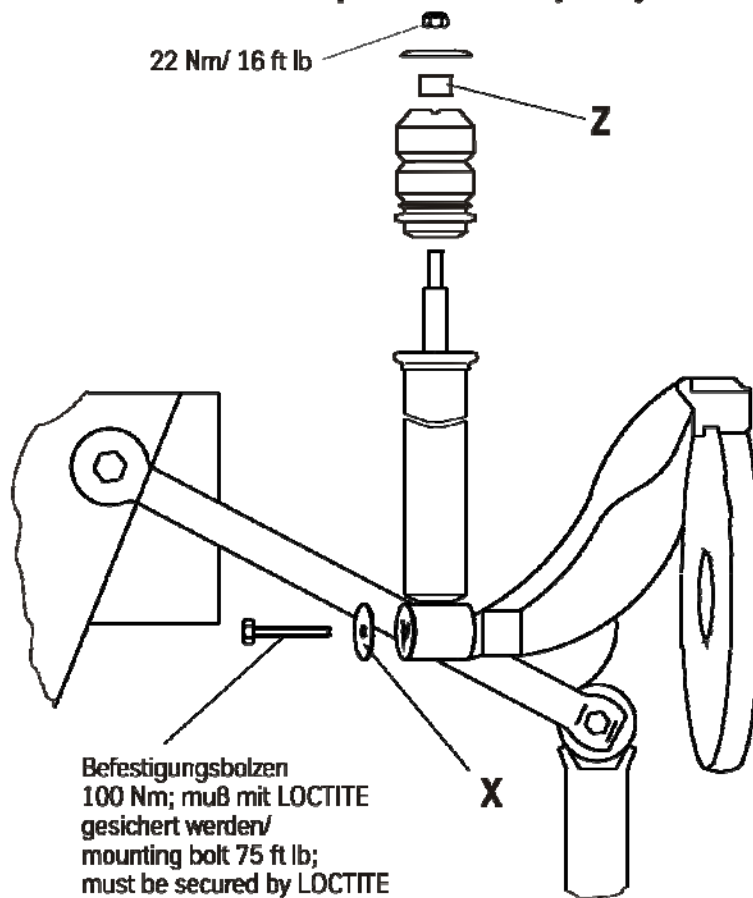

## BMW Z4 (E89)

