

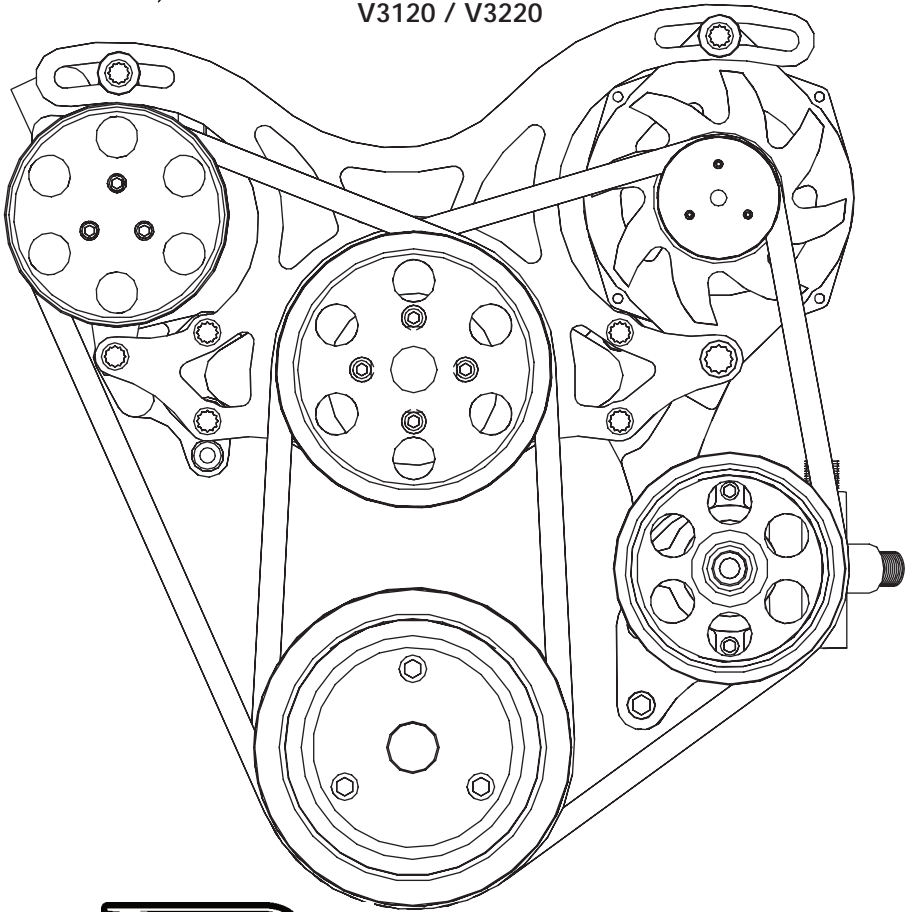

**Trac**

INSTALLATION MANUAL  
CHEVROLET SMALL BLOCK  
V3120 / V3220



# PLEASE READ ALL INSTRUCTIONS BEFORE INSTALLING ANY COMPONENTS OF THE V-TRAC PULLEY SYSTEM

## Required Tools & Materials

- |   |  |                                      |
|---|--|--------------------------------------|
| <input type="checkbox"/> Anti-seize Compound            | <input type="checkbox"/> 11/16" Combo Wrench       | <input type="checkbox"/> 3/16" Allen |
| <input type="checkbox"/> RTV Silicone                   | <input type="checkbox"/> 3/4" Combo Wrench         | <input type="checkbox"/> 5/16" Allen |
| <input type="checkbox"/> Gasket Scraper                 | <input type="checkbox"/> Socket Wrench & Extension | <input type="checkbox"/> 1/4" Allen  |
| <input type="checkbox"/> Scotch-Brite® Pad              | <input type="checkbox"/> 10mm 12pt. socket         | <input type="checkbox"/> 6mm Allen   |
| <input type="checkbox"/> 3/8-16 Thread Chaser* & Holder | <input type="checkbox"/> 12mm 12pt. socket         |                                      |

\*Thread chasers are available at your local parts store and are different from a thread cutting tap.

### Skin Board #1 - Packaged with Power Steering Pump

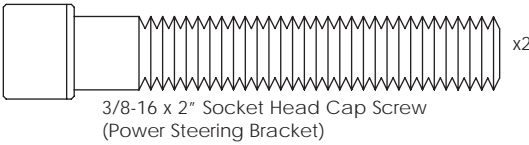
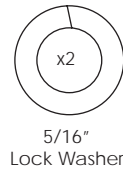
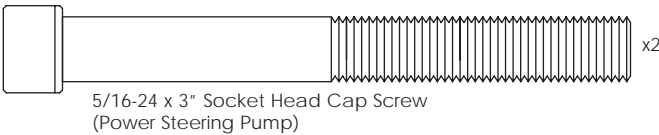

### Skin Board #2 - Packaged with Water Pump

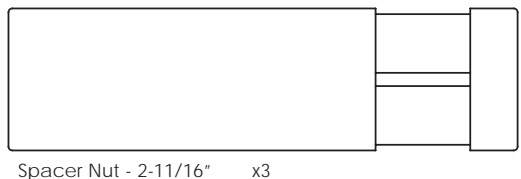
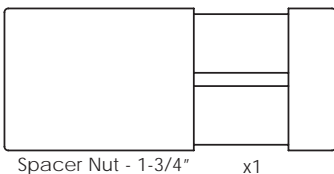
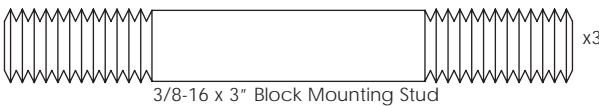

## Skin Board #3 - Packaged In Main Box

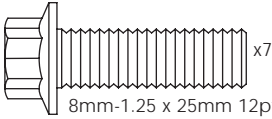

8mm-1.25 x 25mm 12pt. Cap Screw  
(Bridge Bracket) x7

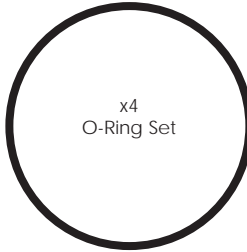

x4  
O-Ring Set



x2  
O-Ring Set

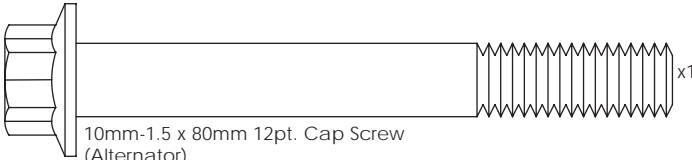

10mm-1.5 x 80mm 12pt. Cap Screw  
(Alternator) x1

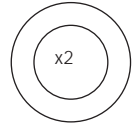

x2  
10mm x .5mm  
Shim Washer

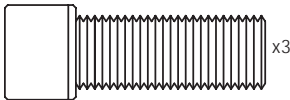

3/8-24 x 1" Socket Head Cap Screw  
(Crankshaft Pulley) x3

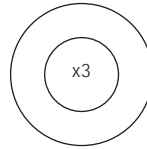

x3  
3/8" Belleville Washer  
(Crankshaft Pulley)

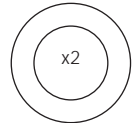

x2  
10mm x 1mm  
Shim Washer

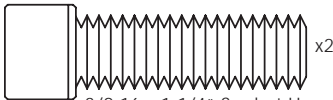

3/8-16 x 1-1/4" Socket Head Cap Screw  
(Alternator Bracket - Not used with Power Steering Kits) x2

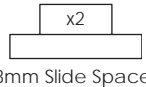

x2  
8mm Slide Spacer

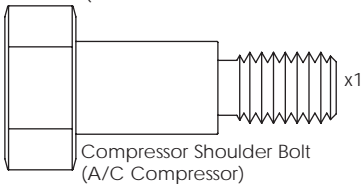

Compressor Shoulder Bolt  
(A/C Compressor) x1

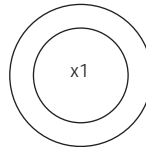

x1  
Compressor Shoulder  
Bolt Washer

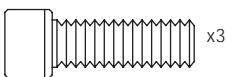

1/4-20 x 3/4"  
Socket Head Cap Screw  
(Compressor Cover) x3

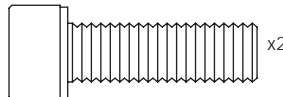

8mm-1.25 x 25mm  
Socket Head Cap Screw  
(A/C Manifold) x2

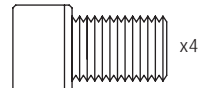

5/16-24x1/2"  
Socket Head Cap Screw  
(Water Pump Pulley) x4

### Other Hardware

Compressor Side Belt - Goodyear #15430 - 42.5"

Alternator Side Belt - With Power Steering Goodyear #15440 - 43.5"

Alternator Side Belt - Without Power Steering Goodyear #15420 - 41.5"

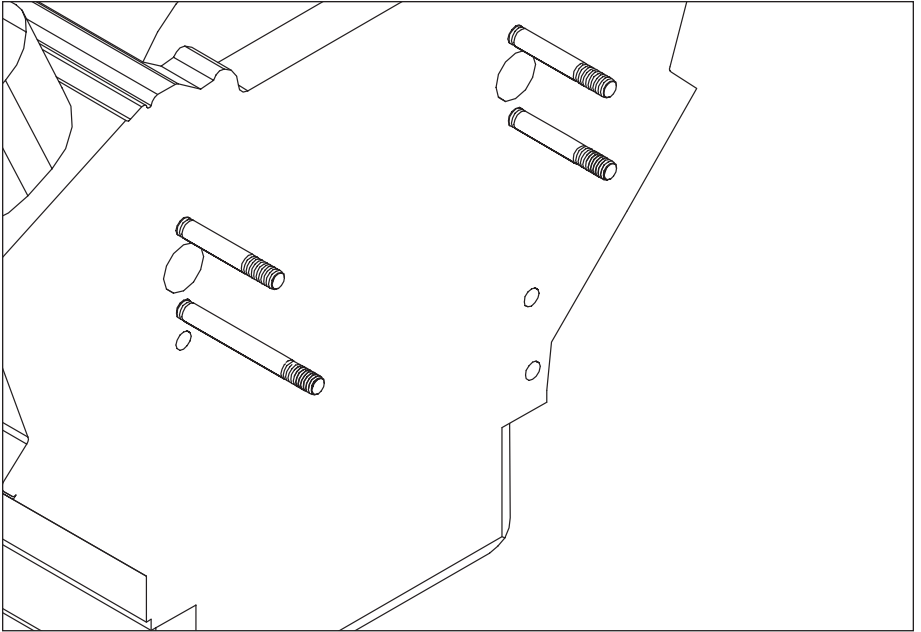

**Figure 1 - Prepping The Block**

Disconnect battery; remove all existing accessory drive brackets and components from motor.

Remove water pump, scrape away any existing gasket material with a gasket scraper and dress surface with a Scotch Brite® pad.

Clean and prep threads on engine block at water pump and driver side bosses by crank (for power steering kits), use a 3/8-16 thread chaser if necessary. Thread chasers are available at your local auto parts store or tool dealer and are different from a thread cutting tool.

Apply RTV sealer to one end of the three 3/8-16 x 3" threaded studs and thread two studs into the driver side water pump mount holes and one stud into the upper passenger side mount hole and tighten.

Apply RTV sealer to one end of the remaining 3/8-16 x 4" stud and thread into the bottom passenger side mount hole and tighten. The studs can easily be tightened by threading two 3/8-16 zinc coated nuts onto the stud and tighten them against each other to act as a drive nut.\*

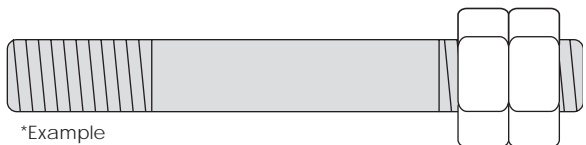

\*Example

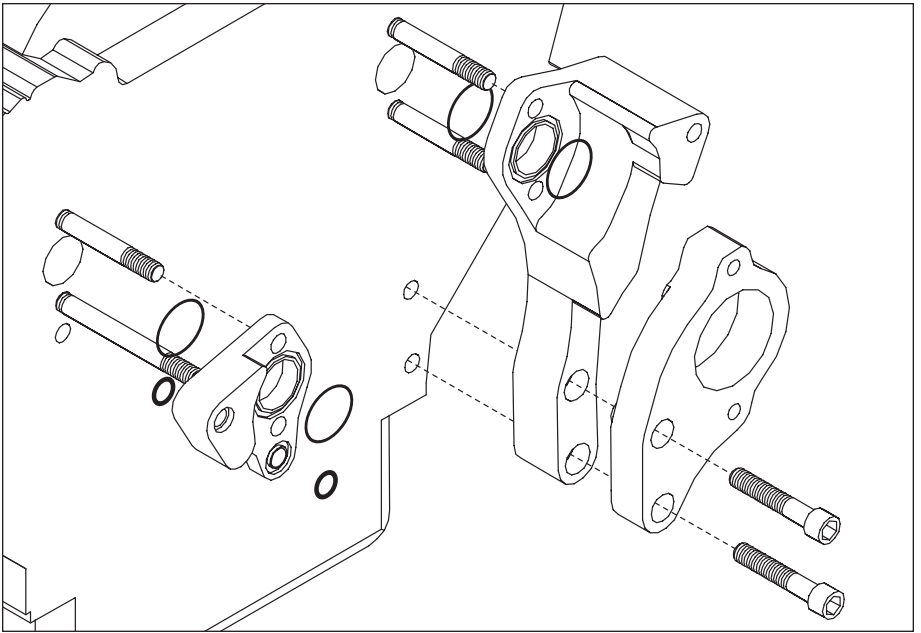

**Figure 2 - Install Alternator & A/C Brackets**

Install the large O-rings into both sides of the passenger side compressor bracket by seating them into the recessed grooves, install the small by-pass O-rings in the same manner. Place bracket over studs and seat up against engine block.

Install the large O-rings into both sides of the driver side alternator bracket by seating them into the recessed grooves. Place bracket over studs and seat up against engine block.

**For kits with power steering** – apply anti-seize to the threads of the two 3/8-16 x 2" socket head cap screws and thread through the power steering bracket, alternator bracket and into engine block and finger tighten.

**For kits without power steering** – apply anti-seize to the threads of the two 3/8-16 x 1-1/4" socket head cap screws and thread through the alternator bracket and into engine block and finger tighten.

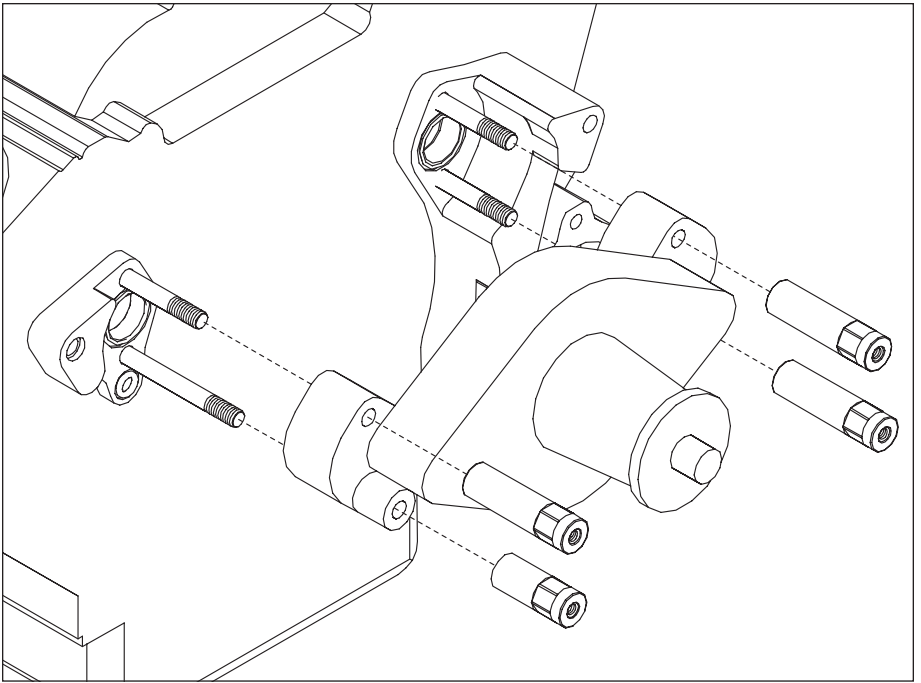

### Figure 3 - Install Water Pump

Install water pump onto studs (make sure O-rings are still seated).

Apply anti-seize to exposed stud threads. Thread the three 2-11/16 spacer nuts onto the short studs with the hex end out.

Thread the remaining 1-7/8" spacer nut to the passenger side bottom stud.

Tighten all spacer nuts firmly at this time. Also tighten lower 3/8" cap screws on alternator bracket or power steering bracket.

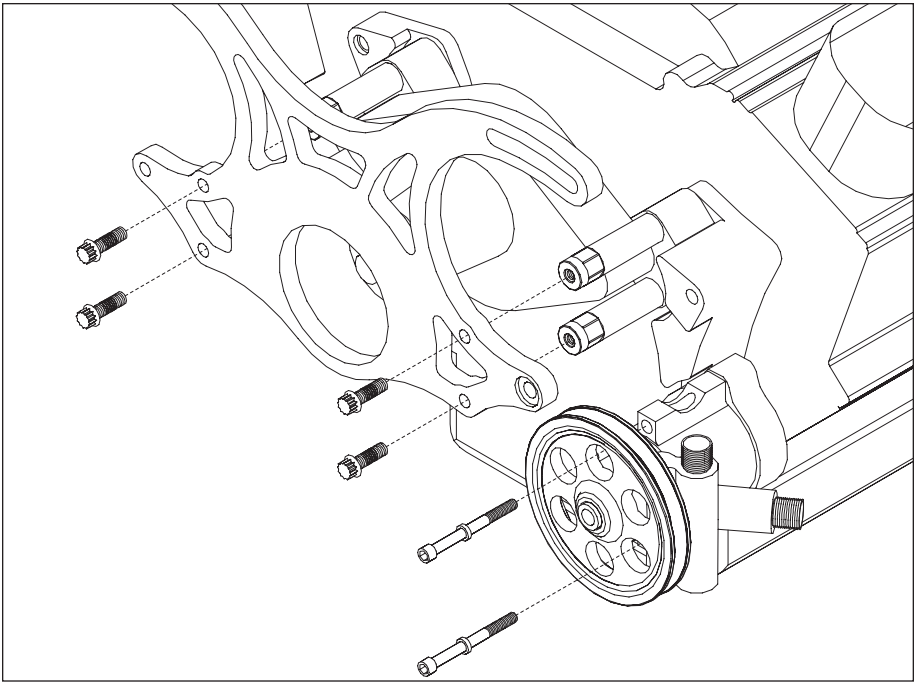
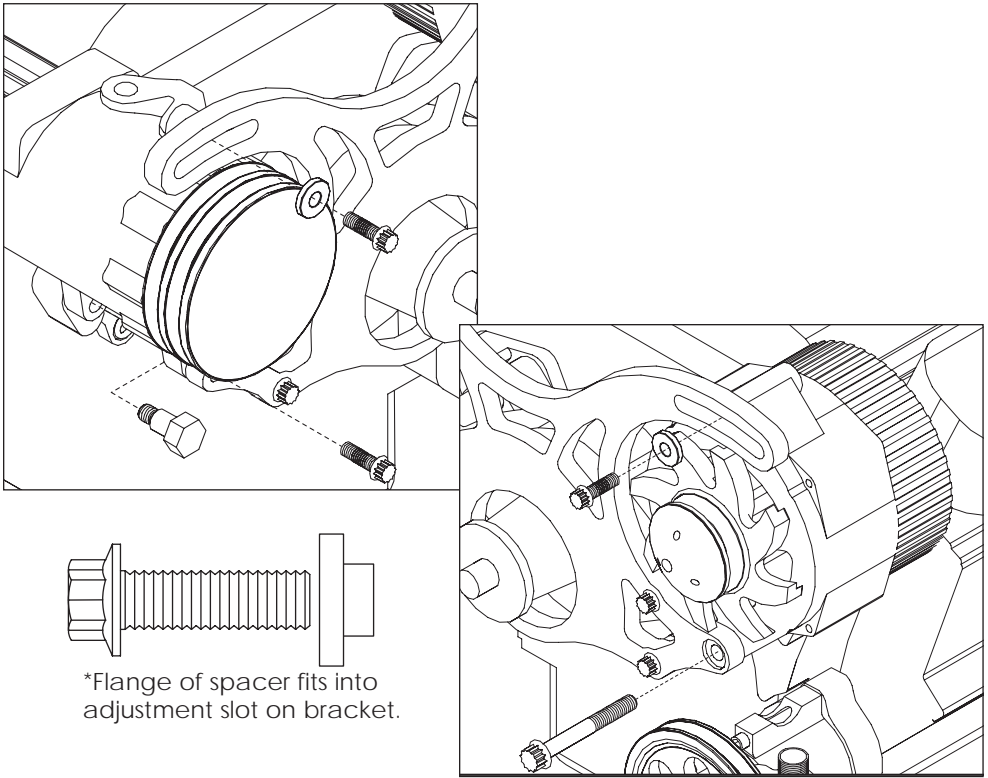

**Figure 4 - Install Power Steering Pump & Bridge Bracket**

*If you do not have power steering proceed to Step 2.*

**STEP 1:** Apply anti-seize to the threads of the two 5/16-24 x 3" socket head cap screws. Place power steering pump and pulley onto bracket and thread the two 5/16" socket head cap screws with 5/16" lock washers through pump into bracket and tighten firmly.

**STEP 2:** Apply anti-seize to the threads of the four 8mm-1.25 x 25mm 12pt. ARP cap screws. Align bridge bracket mount holes with the four spacer nuts. Install the four 8mm 12pt. ARP cap screws and tighten firmly.



## Figure 5 - Install Alternator & A/C Compressor

**Alternator:** Apply anti-seize to the threads of the 10mm-1.5 x 80mm ARP 12pt. cap screw and the 8mm-1.25 x 25mm ARP 12pt. cap screw. Place alternator between lower bridge bracket and alternator bracket and thread the long ARP 12pt. cap screw through the bridge bracket, alternator and into the alternator bracket and finger tighten. 10mm shim washers are provided to shim the lower alternator boss to the bridge bracket. The alternator boss may vary in width due to the polishing process. Place the 8mm slide spacer\* on the short ARP 12pt. cap screw, align top alternator boss with bridge bracket and thread the cap screw with slide spacer through bridge bracket and into alternator boss and finger tighten.

**A/C Compressor:** Apply anti-seize to the threads of the 3/8-16 compressor shoulder bolt and two 8mm-1.25 x 25mm ARP 12pt. cap screws. While supporting the compressor, place the shoulder bolt and washer into the back compressor mount boss and align with compressor bracket on motor and finger tighten. Thread one 8mm ARP 12pt. cap screw through bridge bracket and into lower compressor boss and finger tighten. Place the 8mm slide spacer\* on the short ARP 12pt. cap screw, align top compressor boss with bridge bracket and thread the cap screw with slide spacer through bridge bracket and into compressor boss and finger tighten.



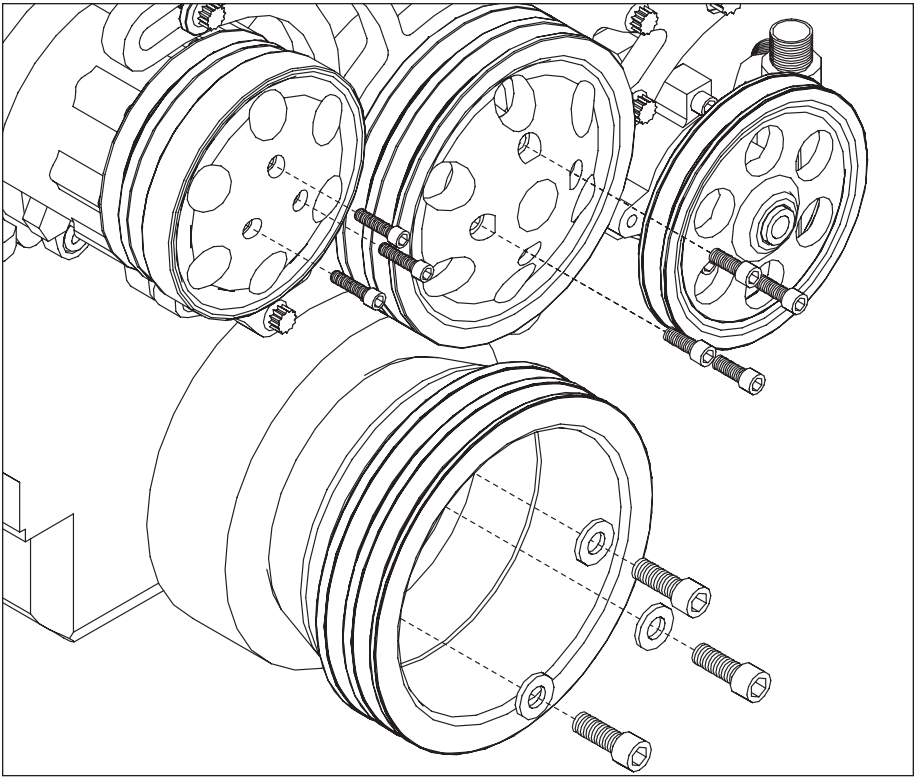

## Figure 6 - Install Crank Pulley, Water Pump Pulley & Compressor Clutch Cover

Install the crank pulley by applying anti-seize to the threads of the three 3/8-24 x 1" socket head cap screws, install the three 3/8" Belleville washers onto each cap screw and thread through crank pulley into damper.

Install the water pump pulley by applying anti-seize to the threads of the four 5/16-24 x 1/2" socket head cap screws and threading them through the water pump pulley into flange.

Install AC Compressor Clutch Cover  
Apply Loctite Blue 242 to the following:  
(3) 1/4-20 x 3/4" socket head cap screws

Place cover on clutch and thread the socket head cap screws through the cover and into the clutch, torque to 40-45 **inch/lbs.**

*Caution:* Over tightening these fasteners will cause damage to the compressor clutch. **Do Not Over Tighten.**

Tighten all fasteners firmly.

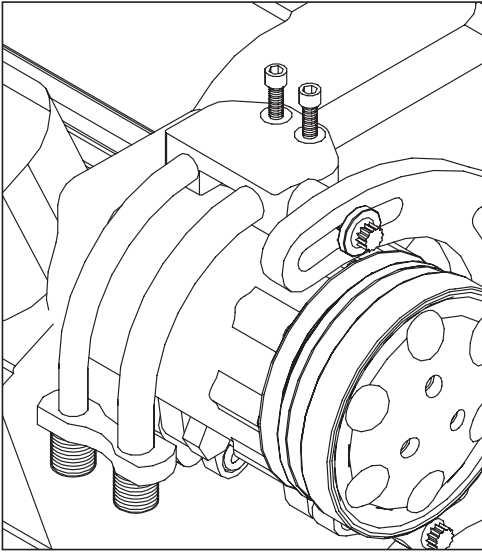

## Figure 7 - Install A/C Compressor Manifold

Compressor Manifold – **Read the precautions below, BEFORE installing the compressor manifold.** To install the manifold remove the bolts & protective cap, being sure to leave the o-rings in place on compressor. Apply anti-seize to the threads of the two 8mm-1.25 x 25mm socket head cap screws. Place manifold on compressor and attach with the two 8mm cap screws and tighten firmly. Attach compressor lines at this point or seal off threaded ends of manifold.

### IMPORTANT

- Only remove sealed cap on compressor and install manifold if you plan on charging your system immediately, leaving the compressor open to outside air can introduce moisture into the system causing the cooling system not to operate properly.
- Never connect the compressor clutch wire and run the compressor unless the system is charged. Serious damage may occur to compressor. Do not install the manifold unless you are going to finish installing the a/c hoses and never connect the compressor clutch wire until system is ready to charge with Freon.
- Although the compressor is supplied with oil, the level may not be correct for the entire system. Consult the instruction manual of the air conditioning unit for proper levels and system charging procedures.
- Billet Specialties recommends having your air conditioning charged and serviced by an automotive air conditioning service center with the proper equipment to ensure many years of proper operation.

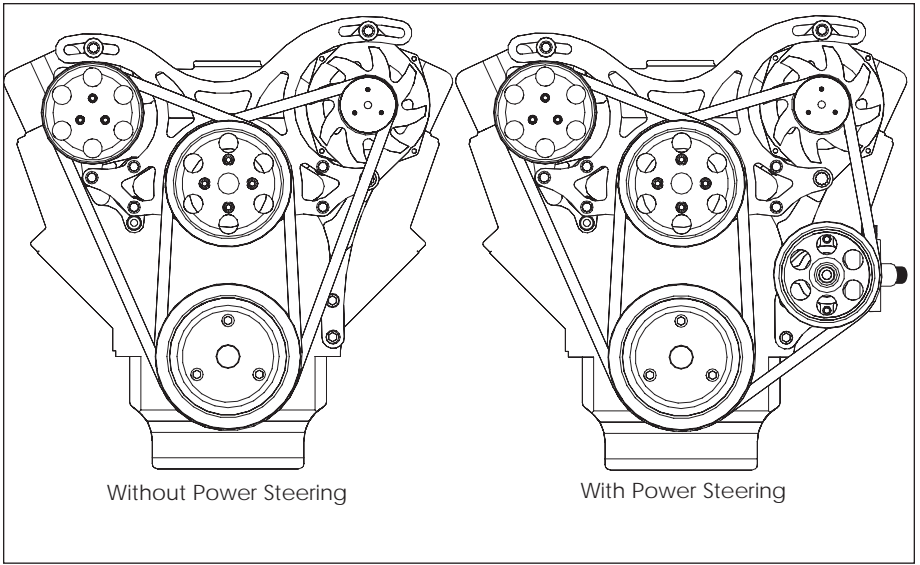

## Figure 8 - Install Belt

Route belts as shown in appropriate diagram, adjust alternator belt tension first. Tighten alternator mounting hardware firmly. Adjust compressor belt tension, tighten rear compressor shoulder bolt firmly then front compressor cap screw firmly. Finish by tightening the top compressor cap screw.

Re-check all fasteners for tightness and proper belt tension. Connect all electrical and start motor and allow to warm up. Turn motor off and re-check fasteners and belts. Re-check after 100 miles.

Alternator Belt Length:

- With Power Steering - 43.5" / Goodyear #15440
- Without Power Steering - 41.5" / Goodyear - #15420

Compressor Belt Length: 42.5" / Goodyear - #15430