



FM0209PC BBC Top Mount Alternator Bracket

Tools Required:

- | | |
|----------------------|--------------------------------------|
| 1/4" Allen Wrench | 9/16" Open End Wrench |
| 5/16" Allen wrench | 7/16-14 Thread Chaser (If necessary) |
| 1/2" Open End Wrench | Anti-Seize |

We recommend applying Anti-Seize to all threads when assembling bracket.

Recommended Belt: Goodyear 6 Rib #4060460 (46") or Dayco #5060460 (46.1")

- 1) Disconnect battery & remove existing accessory drive brackets.
- 2) Clean & prep threads in passenger cylinder head (outside hole) and left side of water pump. Run a 7/16-14 thread chaser if necessary.
- 3) Thread the 7/16-14 x 1-1/4" threaded stud into the outside passenger side cylinder head and finger tighten. For aftermarket cylinder heads with 3/8" tapped holes use the included 3/8 to 7/16 adapter. There should be no more than 5/8" of thread left exposed. (if more than 5/8" thread is showing, remove stud and clean out threads then reinstall threaded stud and check again) Apply anti-seize to the exposed threads on the stud. Also apply anti-seize to the threads of all the remaining fasteners at this time.
- 4) Thread the 3-11/32" spacer nut onto the exposed stud and tighten firmly.
- 5) Attach the alternator bracket to the water pump with the two 3/8-16 x 3/4" stainless socket head cap screws and finger tighten.
- 6) Thread the 3/8-16 x 1-1/4" stainless socket head cap screw through one end of the turnbuckle assembly and the 3/16" spacer into the water pump boss and tighten firmly. Swing the turnbuckle to the right and lay to rest out of the way.
- 7) Attach the alternator ear bracket to the top alternator boss with the 5/16-18 x 3/4" stainless socket head cap screw and tighten (26 ft./lb.).
- 8) Place the alternator between the spacer nut and alternator bracket and thread the 3/8-16 x 2-3/4" stainless socket head cap screw through the Alternator bracket & alternator into the spacer nut and finger tighten.
- 9) Swing the alternator up into position and match up to the turnbuckle assembly, thread the 3/8-16 x 1" through the turnbuckle rod end into the alternator ear bracket and tighten (46ft./lb.).
- 10) Route belt around alternator, water pump and crank pulleys. Twist turnbuckle by hand until proper belt tension is achieved. Do not over-tighten belt! Serious damage may occur to the accessory drive bearings resulting in premature wear.
- 11) Tighten jam nuts on turnbuckle. Tighten alternator socket head screw (46ft./lb.) Tighten alternator bracket screws on water pump (46ft./lb.) Re-check belt tension.
- 12) Reconnect electrical and test run motor. Re-check belt tension after 100 miles.

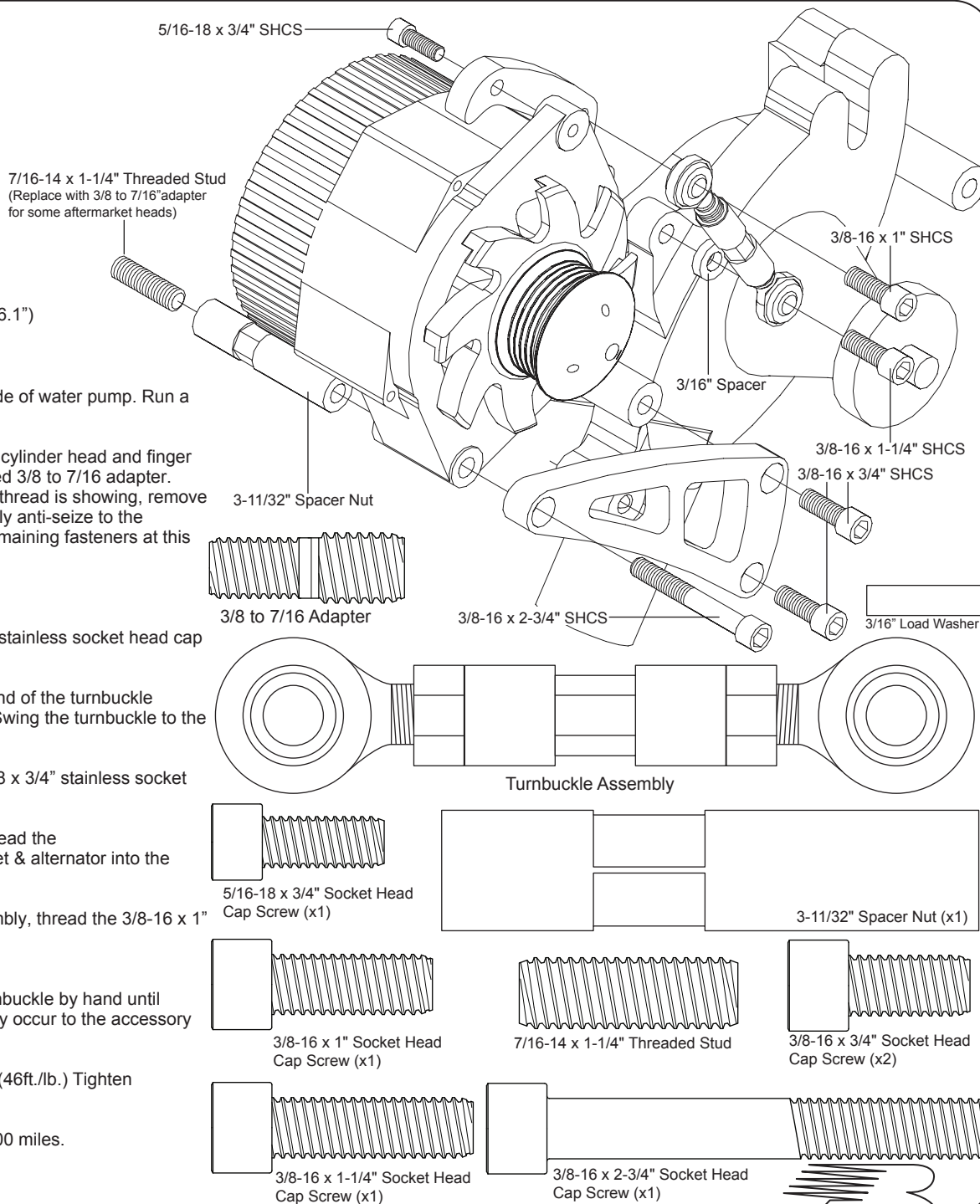



FM0230PC BBC Power Steering Bracket

Tools Required:	3/8-16 Thread chaser (If necessary)
5/16" Allen wrench	7/16-14 Thread chaser (If necessary)
3/8" Allen wrench	New water pump to engine block gaskets
1/2" Open-end wrench	RTV silicone sealer
9/16" Open-end wrench	Anti-seize

It is recommended that you use the proper tools to remove and install the power steering pulley. KD Tools P/N2897 puller and installer set or similar will insure proper pulley service. Some auto parts stores rent out tool sets.

Recommended Belt: Goodyear 6 Rib #4060385 (38.5")* or Dayco #5060388 (38.8")*

*If running power steering only

- 1) Disconnect battery, drain coolant, & power steering fluids. Disconnect coolant & power steering lines. Remove all existing accessory drive brackets and components from motor.
- 2) Remove existing power steering bracket and pulley (press on pulleys require the use of a special puller to avoid damage to power steering pump and pulley – see tool list)
- 3) Remove water pump, scrape away any existing gasket material.
- 4) Clean and prep threads in cylinder heads, use a thread chaser if necessary. 7/16-14 in engine block & 3/8-16 in water pump.
- 5) Thread the 3/8-16 x 2-1/2" threaded studs from the power steering skin board into the driver side water pump mount holes and tighten. The studs can easily be tightened by threading two 3/8-16 nuts (not included) onto the stud and tighten them against each other to act as a drive nut. Apply RTV sealer to engine block and water pump.
- 6) Install gaskets and then water pump. There should be no more than 5/8" of thread left exposed on studs. If more than 5/8" thread is showing, remove stud(s) and clean out threads then reinstall threaded stud(s) and check again. Apply anti-seize to the exposed threads on the studs. Also apply anti-seize to the threads of all the remaining fasteners at this time.
- 7) Thread the two 2" long spacer nuts (from the power steering kit) onto the exposed studs with the hex end out and install the passenger side water pump bolts to complete installation of water pump. Tighten firmly.
- 8) Attach the steel three hole power steering bracket to the front of pump with two 3/8-16 x 3/4" socket head cap screws and tighten firmly (46 ft/lb). Attach steel adjustment bracket to the back of the power steering pump with one 3/8-16 x 3/4" socket head cap screw and finger tighten.
- 9) Place pump assembly on motor and align three hole steel bracket with water pump boss by the spacer nuts. Thread the 1/2-13 x 3/4" socket head cap screw through the bracket and into the water pump and finger tighten.

Swing the rear steel bracket up and align with engine block lower mount boss, thread a 7/16-14 x 1-1/2" socket head cap screw through the thin 7/16" ID slide spacer, the rear steel bracket and the 21/32" long rear spacer into the engine block and finger tighten. Note: the spacers have a lip that locates them in the adjustment slot of the bracket.

10) Thread a 3/8-16 x 1" socket head cap screw through one thin 3/8" ID slide spacer, the aluminum power steering bracket and one more thin 3/8" ID slide spacer and into the power steering pump. Finger tighten.

11) Thread the two remaining 3/8-16 x 3/4" socket head cap screws through the aluminum bracket and into the water pump spacer nuts and tighten firmly (46 ft/lbs). Do not install top bolt if installing kits with A/C #FM2213PC or #FM2214PC.

12) Install pulley:

For pumps with a keyed shaft – Place the pulley onto shaft, install thrust washer and nut. Tighten nut.

For Pumps with a press on shaft – Always use a pump pulley installer to push the pulley onto the shaft. The hub of the pulley should be flush with the end of the pump drive shaft. Follow the instructions provided with the pulley installation tool.

Do not press or hammer the pulley onto the shaft, this will destroy the pump.

13) For bracket kits that are included with a serpentine conversion kit skip the next step and go on to step 15

14) Install belt (38-1/2" recommended); adjust belt tension by moving pump in brackets. When proper belt tension has been achieved, tighten all fasteners firmly. Check belt tension again and adjust if necessary. Do not over tighten belt! Serious damage may occur to the accessory drive bearings resulting in premature wear. Go to step 16.

15) Only if you have purchased a complete serpentine conversion kit. Align pump so that the fill cap is level, tighten all fasteners firmly. Install power steering lines and fittings at this time. Return to the main kit instructions at this time.

16) Install power steering lines and fittings, inspect hoses for kinks or nicks and replace as necessary. Fill reservoir to the proper level and test run motor. Re-check belt tension and adjust if necessary. Re-check belt tension after 100 miles.

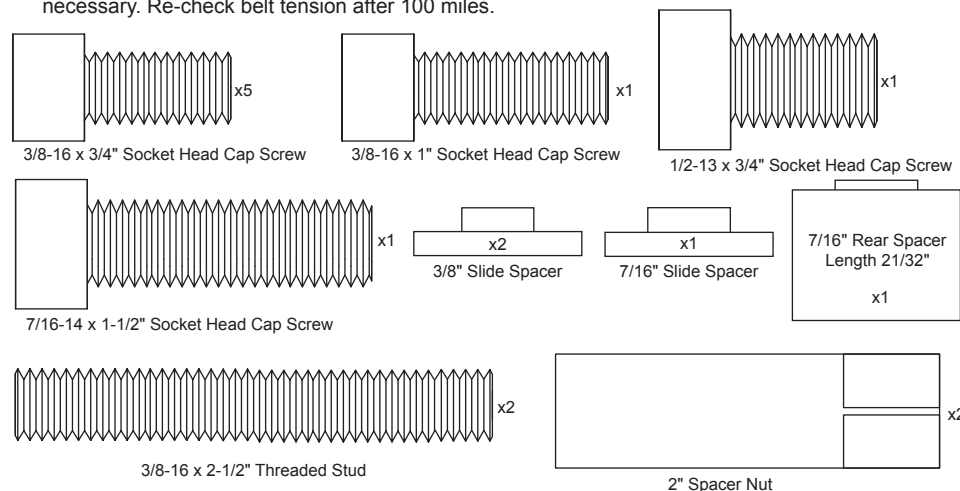

FM0230PC BBC Power Steering Bracket

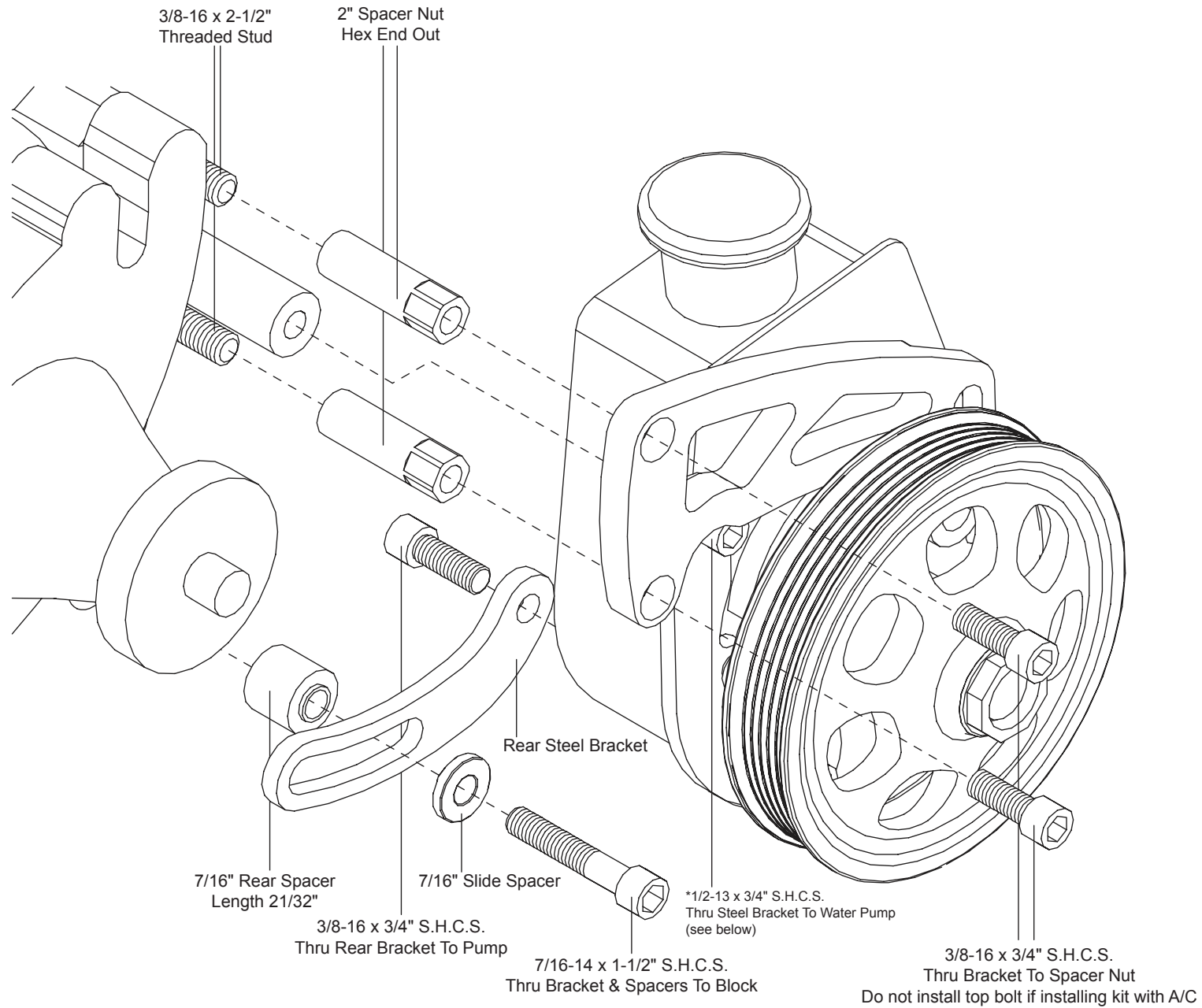

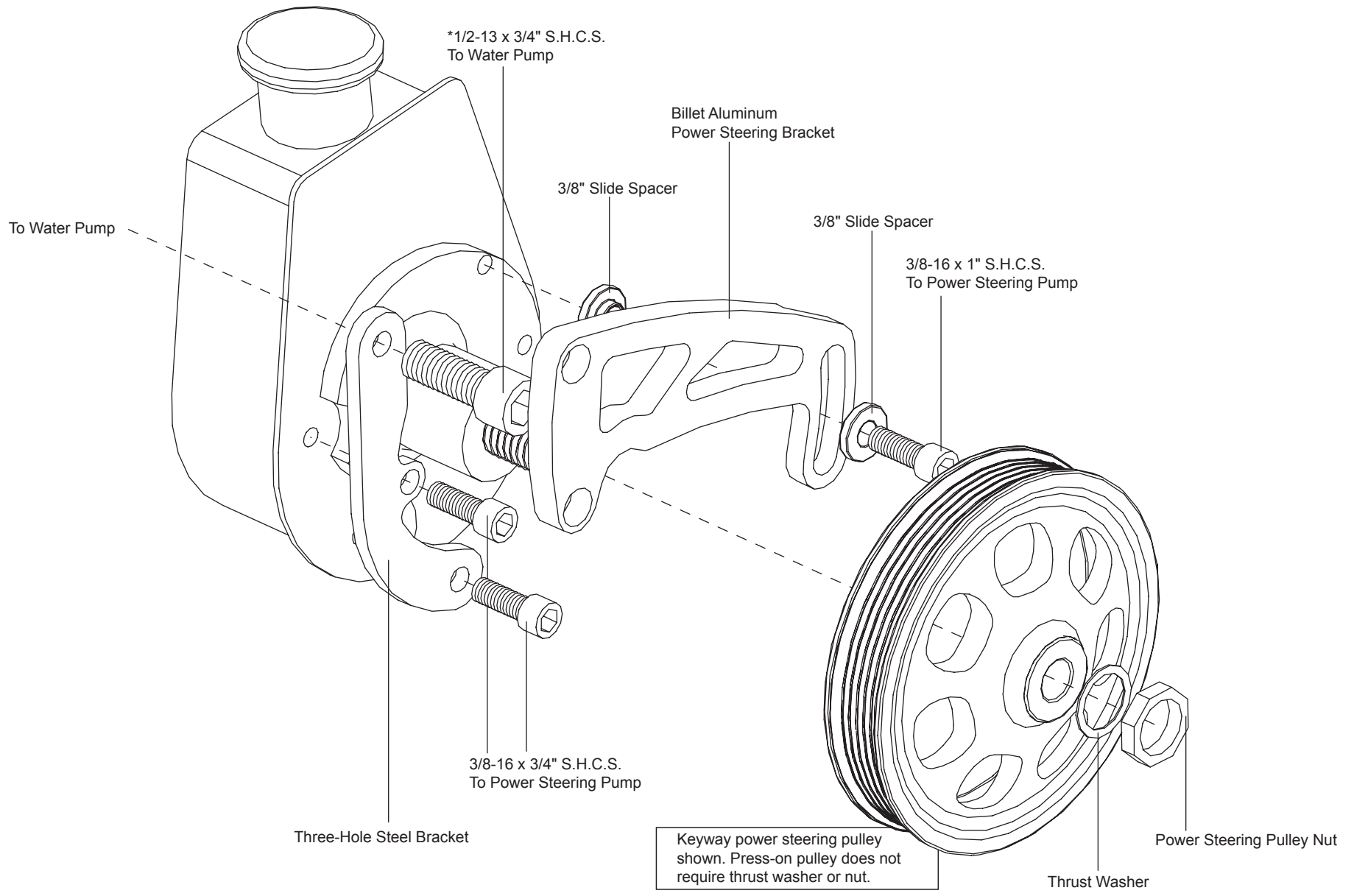



FM3210PC BBC Serpentine Pulley Kit - LWP

ALTERNATOR PULLEY

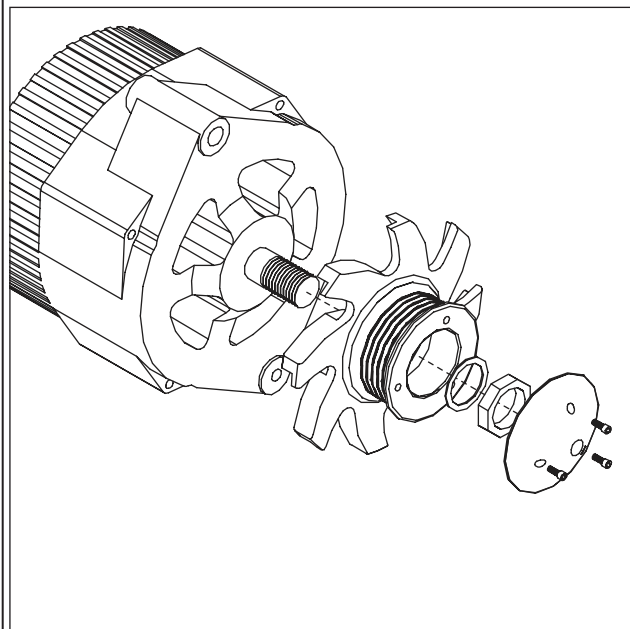
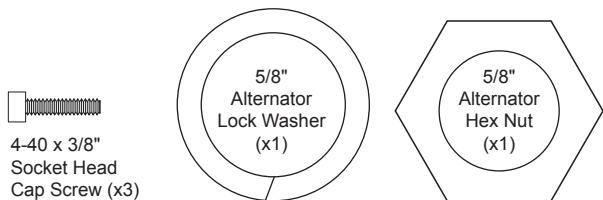

Tools Required:
3/32" Allen wrench
15/16" Socket

WATER PUMP PULLEY

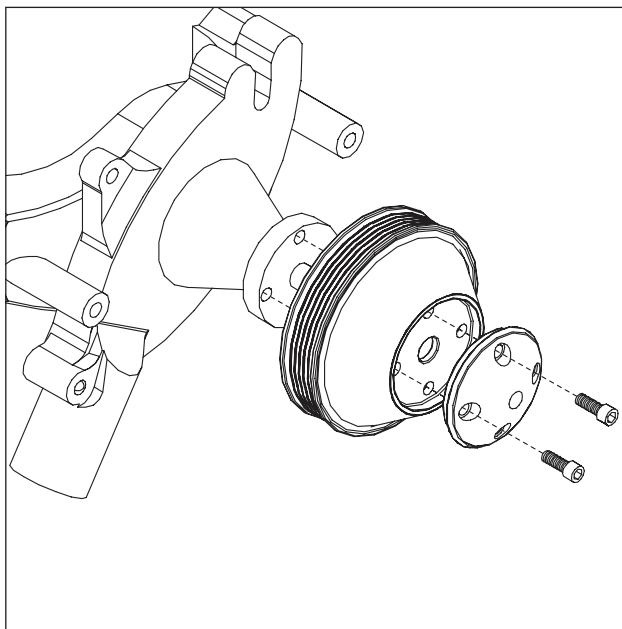
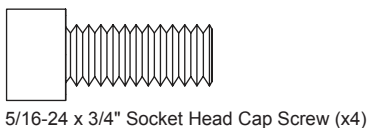

Tools Required:
1/4" Allen wrench

CRANKSHAFT PULLEY

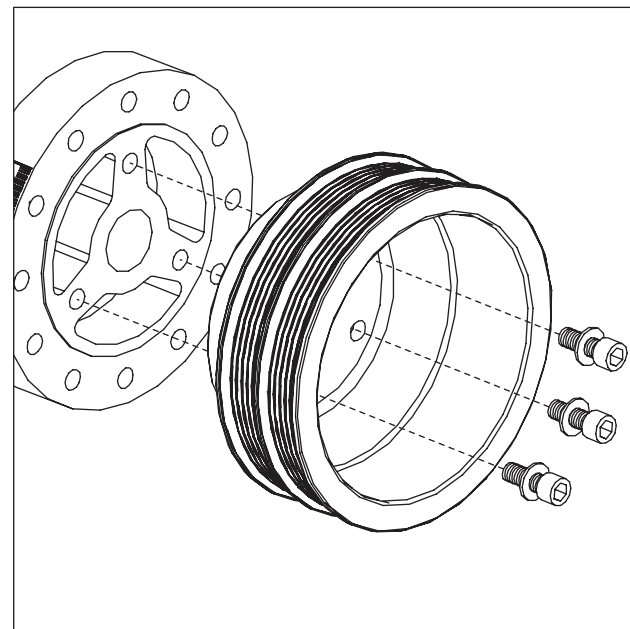
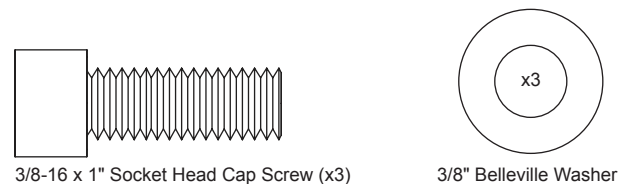

Tools Required:
5/16" Allen wrench

