



FM0109PC SBC Top Mount Alternator Bracket

Tools Required:

- | | |
|----------------------|-------------------------------------|
| 1/4" Allen Wrench | 9/16" Open End Wrench |
| 5/16" Allen wrench | 3/8-16 Thread Chaser (If necessary) |
| 1/2" Open End Wrench | Anti-Seize |

We recommend applying Anti-Seize to all threads when assembling bracket.

Recommended Belt: Goodyear 6 Rib #4060445 (44.5") or Dayco 6 Rib #5060445 (44.5")

- 1) Disconnect battery. Remove existing accessory drive brackets.
- 2) Clean & prep threads in passenger cylinder head (outside hole) and left side of water pump. Run a 3/8-16 thread chaser if necessary. Thread chasers are available at your local auto parts store or tool dealer and are different from a thread cutting tool.
- 3) Thread the 3/8-16 x 1-1/4" threaded stud into the outside passenger side cylinder head and finger tighten. There should be no more than 5/8" of thread left exposed (if more than 5/8" thread is showing, remove stud and clean out threads then reinstall threaded stud and check again). Apply anti-seize to the exposed threads on the stud. Also apply anti-seize to the threads of all the remaining fasteners at this time.
- 4) Thread the 3-11/32" spacer nut onto the exposed stud and tighten firmly.
- 5) Attach the alternator bracket to the water pump with the two 3/8-16 x 3/4" stainless socket head cap screws and finger tighten.
- 6) Thread the 3/8-16 x 1-3/4" stainless socket head cap screw through one end of the turnbuckle assembly and the 3/4" spacer into the water pump boss and tighten firmly. Swing the turnbuckle to the right and lay to rest out of the way.
- 7) Attach the alternator ear bracket to the top alternator boss with the 5/16-18 x 3/4" stainless socket head cap screw and tighten (26 ft./lb.).
- 8) Place the alternator between the spacer nut and alternator bracket and thread the 3/8-16 x 2-3/4" stainless socket head cap screw through the Alternator bracket & alternator into the spacer nut and finger tighten.
- 9) Swing the alternator up into position and match up to the turnbuckle assembly, thread the 3/8-16 x 1" stainless socket head cap screw through the turnbuckle rod end into the alternator ear bracket and tighten (46ft./lb.).
- 10) Route belt around alternator, water pump and crank pulleys. Twist turnbuckle by hand until proper belt tension is achieved. Do not over-tighten belt! Serious damage may occur to the accessory drive bearings resulting in premature wear.
- 11) Tighten jam nuts on turnbuckle. Tighten alternator socket head screw (46ft./lb.) Tighten alternator bracket screws on water pump (46ft./lb.) Re-check belt tension.
- 12) Reconnect electrical and test run motor. Re-check belt tension after 100 miles.

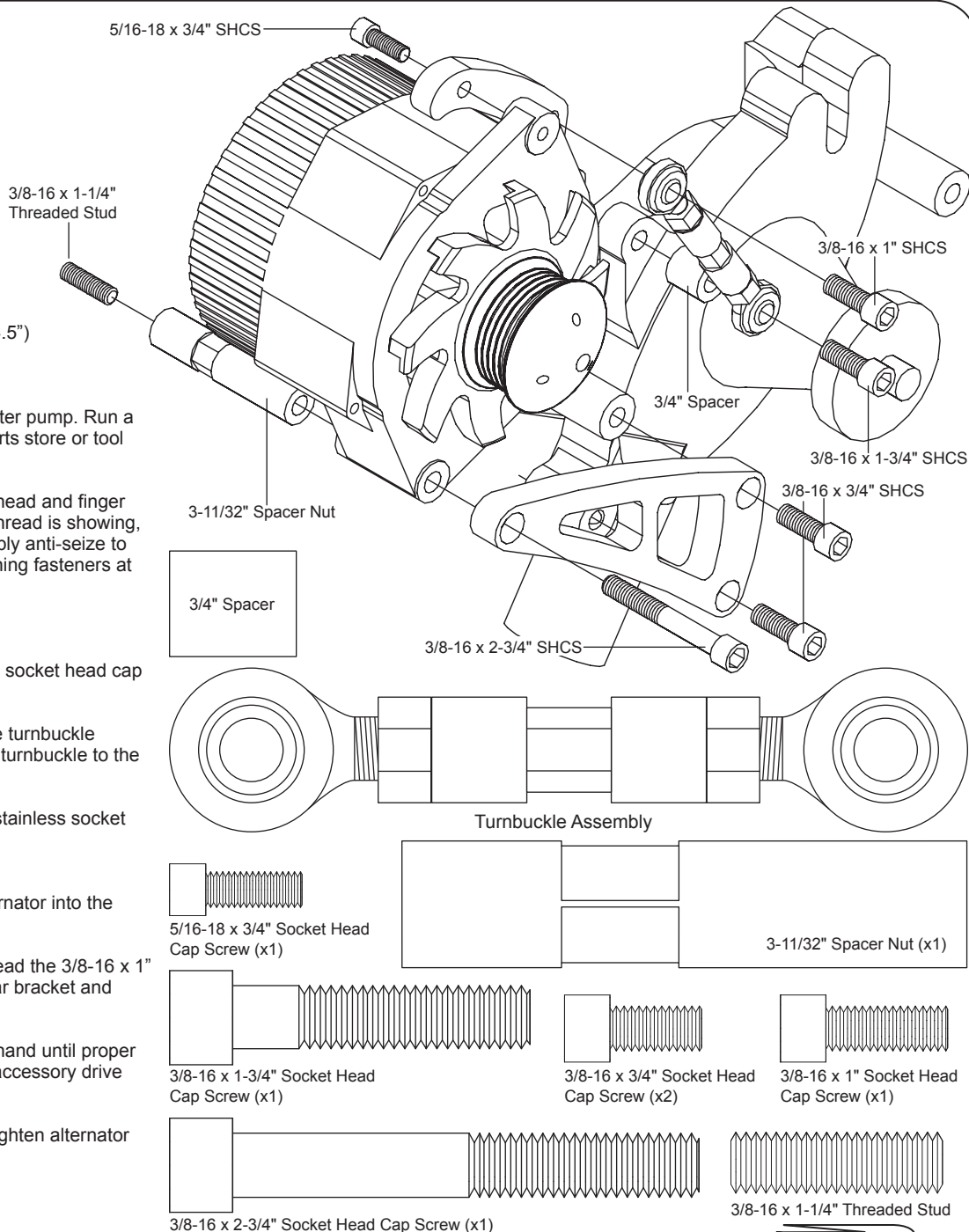



FM3110PC SBC Serpentine Pulley Kit - LWP

ALTERNATOR PULLEY

4-40 x 3/8"
Socket Head
Cap Screw (x3)

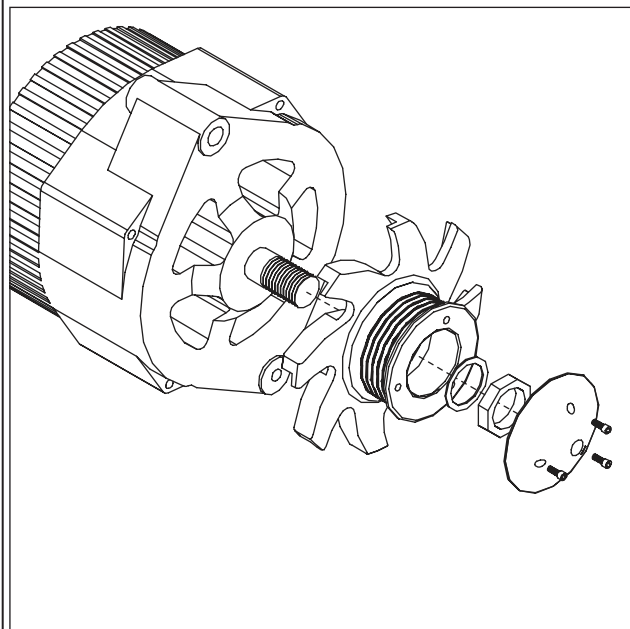
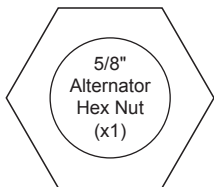
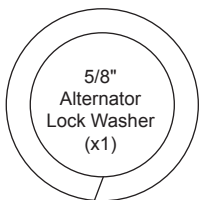

Tools Required:
3/32" Allen wrench
15/16" Socket

WATER PUMP PULLEY

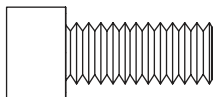

5/16-24 x 3/4" Socket Head Cap Screw (x4)

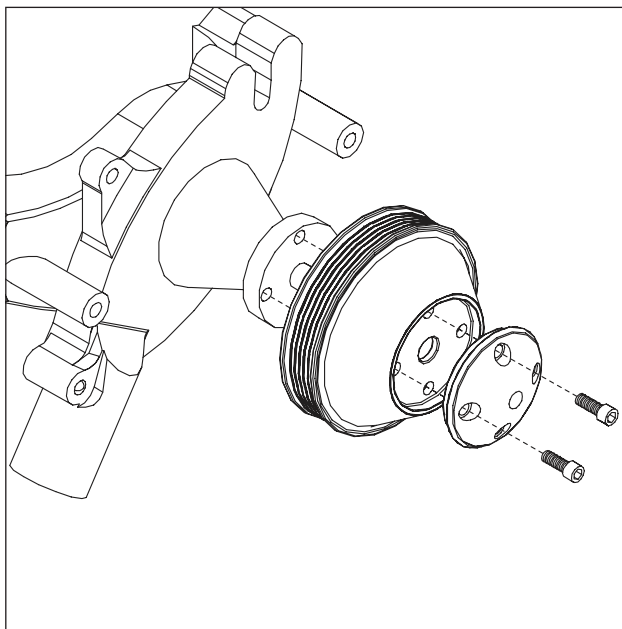

Tools Required:
1/4" Allen wrench

CRANKSHAFT PULLEY

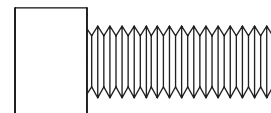

3/8-24 x 1" Socket Head Cap Screw (x3)

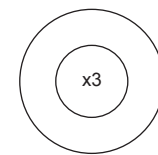

3/8" Belleville Washer

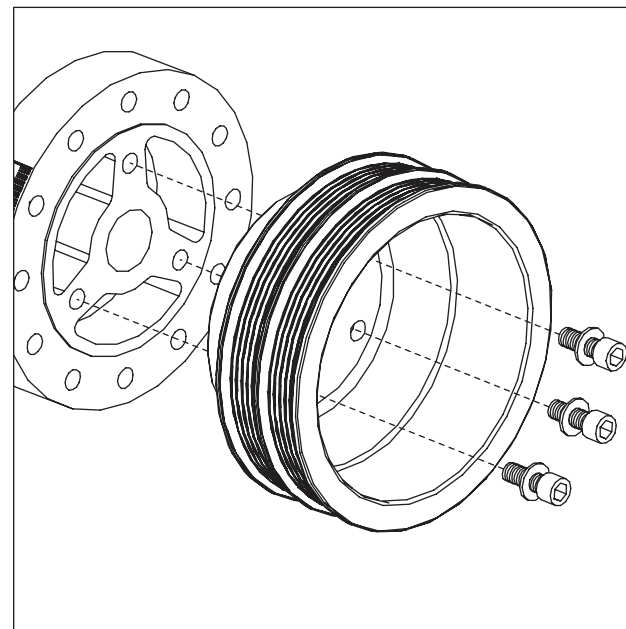

Tools Required:
5/16" Allen wrench

