



## FM1325PC BBC Top Mount A/C Bracket

Tools Required:  
5/32" Allen wrench  
1/4" Allen wrench  
3/16" Allen wrench  
5/16" Allen wrench  
1/2" Open-end wrench

9/16" Open-end wrench  
Anti-seize

Recommended Belt: Goodyear Poly-V 6 Rib #4060605 (60.5") or Dayco #5060605 (60.5")

- 1) Disconnect battery & remove all existing accessory drive brackets and components from motor.
- 2) Place the idler stand-off into the compressor bracket. Note: Idler stand off has an oval key that fits into like receptacle on bracket. Thread the 3/8-16 x 2-1/2" socket head cap screw through the back of the compressor bracket into the idler stand off bracket and tighten. This fastener will be torqued after the next step.
- 3) Attach the compressor bracket to the driver side cylinder head (outside holes nearest to the exhaust manifold) with the 3/8-16 x 3/4" socket head cap screw at the bottom of the bracket and the 3/8-16 x 1" socket head cap screw at the top of the cylinder head and tighten firmly (46 ft/lbs each). At this time, tighten the idler stand off bolt from step 2 (46 ft/lbs).
- 4) Attach the turnbuckle assembly to the top left boss on A/C bracket by threading a 3/8-16 x 1-1/4" socket head cap screw through the turnbuckle assembly and 3/16" load washer and into the compressor bracket, tighten firmly (46 ft/lb). Swing turnbuckle to rest on water pump.
- 5) At this time remove the 3/8-16 X 3/4 socket head cap screw from the top hole on the Power steering Bracket and set aside.
- 6) Install the compressor by aligning the compressor bosses with the compressor bracket, thread the 3/8-16 x 5" socket head cap screw through the compressor and bracket. Thread the 3/8-16 nut and 3/8" lock washer onto the back and finger tighten.
- 7) Thread the 3/8-16 x 1" socket head cap screw through the compressor ear (see figure) and into the 1-3/4" long front spacer nut and tighten. Swing the compressor up to match up the front spacer nut with the turnbuckle assembly, thread the 3/8-16 x 2-1/2" socket head cap screw through the rear compressor ear (see figure) and through the 1-1/16 spacer and turnbuckle assembly into the front spacer nut and tighten.

Works with the following Billet Specialties part numbers;  
FM 2211PC & FM2212PC BBC Top Mount - Alternator & Power Steering Kit.  
FM 2221PC & FM2222PC BBC Mid Mount - Alternator & Power Steering Kit.

If you do not have either of the above kits - Do Not Attempt to Install

8) Place the stainless bearing sleeve into the 3-1/4" diameter idler pulley (long end of the sleeve goes into the bearing from backside of pulley). Insert assembly into the upper hole of the power steering bracket. Thread the 3/8-16 x 2-1/2" socket head cap screw with 3/8" x 7/8" OD stainless washer through the pulley and sleeve into the power steering bracket and tighten. Install the idler pulley cover with the three #10-32 x 1/2" socket head cap screws and tighten. Install the compressor cover with the three 1/4-20 x 3/4" socket head cap screws and tighten.

9) Route belt as shown in figure 2. Place bearing sleeve into 2-1/2" dia. pulley (long end of the sleeve goes into the bearing from backside of pulley). Place idler pulley on belt and push belt and pulley into position to line up with compressor bracket boss. Thread a 3/8-16 x 2-1/4" socket head cap screw with 3/8" x 7/8" OD stainless washer through the pulley and sleeve into the 1-1/2" aluminum Idler stand off. Tighten firmly (46 ft/lbs). Install idler pulley cover with three #10-32 x 1/2" socket head cap screws and tighten.

10) Adjust belt tension by twisting the two turnbuckle assemblies by hand until proper belt tension is achieved. Do not over-tighten belt! Serious damage may occur to the accessory drive bearings resulting in premature wear. Tighten jam nuts on turnbuckle. Tighten alternator socket head cap screws (46 ft/lbs). Tighten compressor socket head screws (46 ft/lbs) and compressor swivel bolt and nut with lock washer firmly. Re-check belt tension.

11) Reconnect electrical and install A/C lines and fittings. Caution: Do not connect A/C compressor electrical until system is properly charged. Test run motor and re-check belt tension, adjust if necessary. Re-check belt tension after 100 miles.





## FM1325PC BBC Top Mount A/C Bracket

Fasteners shown are for A/C compressor bracket assembly. Refer to Alternator, Power Steering, & Pulley Installation instructions for additional information.

### Tools Required:

- 5/32" Allen wrench
- 1/4" Allen wrench
- 3/16" Allen wrench
- 5/16" Allen wrench
- 1/2" Open-end wrench
- 9/16" Open-end wrench
- 3/8-16 Thread chaser (If necessary)
- 7/16-14 Thread chaser (If necessary)
- New water pump to engine block gaskets
- RTV silicone sealer
- Anti-seize

Recommended Belt: Goodyear Poly-V 6 Rib #4060605 (60.5")

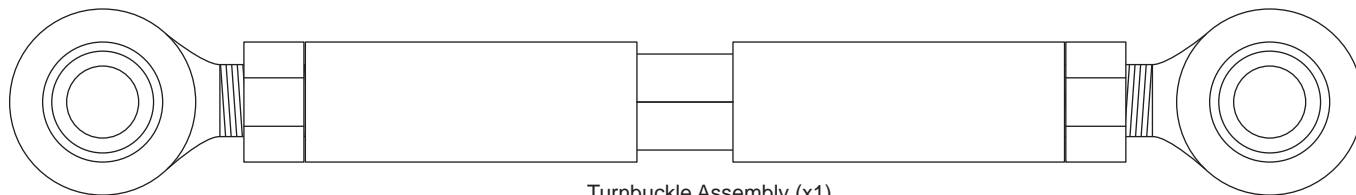

Turnbuckle Assembly (x1)

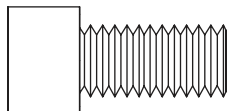

3/8-16 x 3/4" Socket Head Cap Screw (x1)

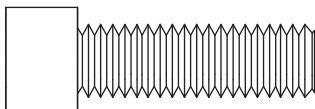

3/8-16 x 1-1/4" Socket Head Cap Screw (x1)

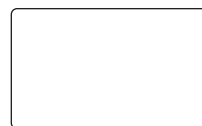

1-1/16" Rear Spacer (x1)

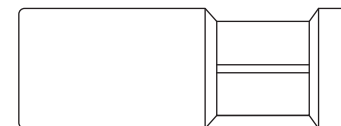

1-3/4" Front Spacer (x1)

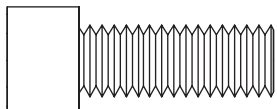

3/8-16 x 1" Socket Head Cap Screw (x2)

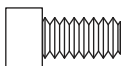

#10-32 x 1/2" Socket Head Cap Screw (x6)

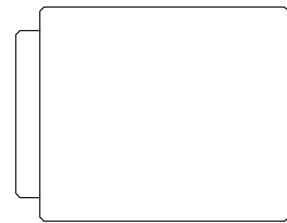

Idler Stand-Off (x1)

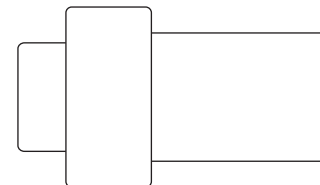

Bearing Sleeve (x2)

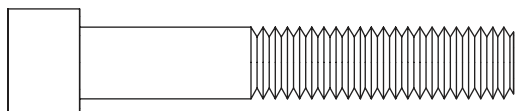

3/8-16 x 2-1/4" Socket Head Cap Screw (x1)

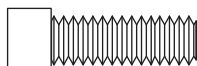

1/4-20 x 3/4" Socket Head Cap Screw (x3)

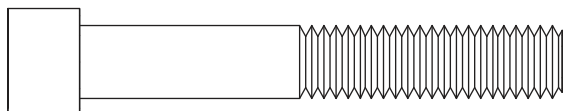

3/8-16 x 2-1/2" Socket Head Cap Screw (x3)

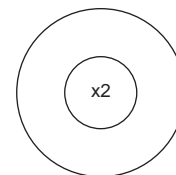

3/8 x 7/8" Flat Washer

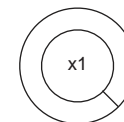

3/8" Lock Washer

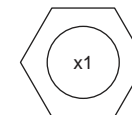

3/8"-16 Hex Nut

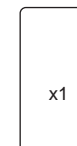

3/16" Load Washer



3/8-16 x 5" Socket Head Cap Screw (x1)





# FM1325PC BBC Top Mount A/C Bracket

Figure 2: BELT PATH

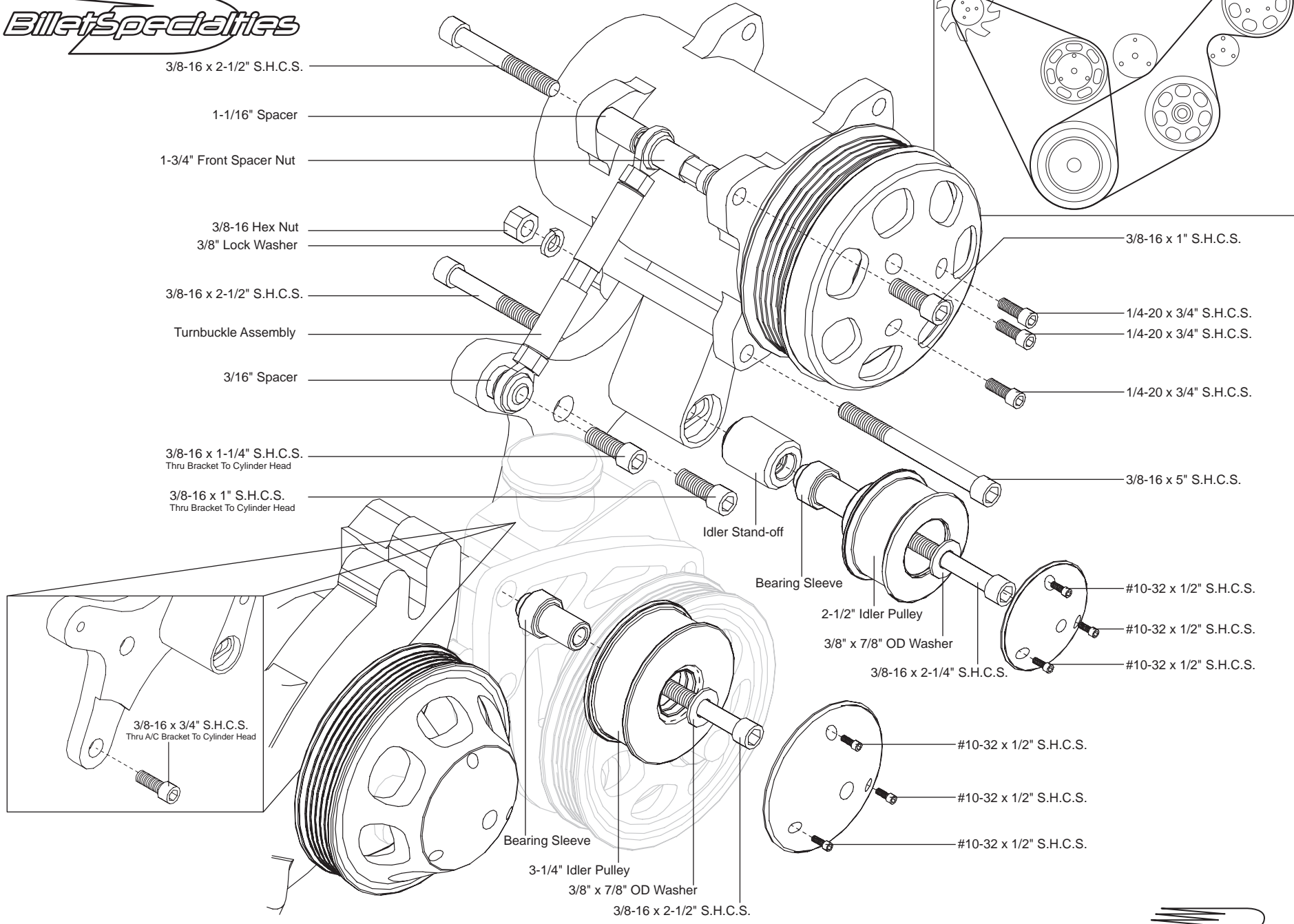
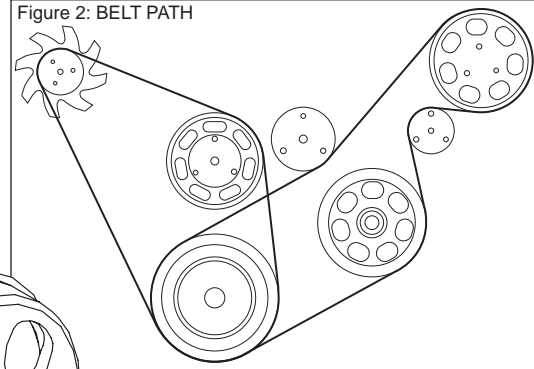

3/8-16 x 2-1/2" S.H.C.S.

1-1/16" Spacer

1-3/4" Front Spacer Nut

3/8-16 Hex Nut  
3/8" Lock Washer

3/8-16 x 2-1/2" S.H.C.S.

Turnbuckle Assembly

3/16" Spacer

3/8-16 x 1-1/4" S.H.C.S.  
Thru Bracket To Cylinder Head

3/8-16 x 1" S.H.C.S.  
Thru Bracket To Cylinder Head

3/8-16 x 1" S.H.C.S.

1/4-20 x 3/4" S.H.C.S.

1/4-20 x 3/4" S.H.C.S.

1/4-20 x 3/4" S.H.C.S.

3/8-16 x 5" S.H.C.S.

Idler Stand-off

Bearing Sleeve

2-1/2" Idler Pulley

3/8" x 7/8" OD Washer

3/8-16 x 2-1/4" S.H.C.S.

#10-32 x 1/2" S.H.C.S.

#10-32 x 1/2" S.H.C.S.

#10-32 x 1/2" S.H.C.S.

3/8-16 x 3/4" S.H.C.S.  
Thru A/C Bracket To Cylinder Head

Bearing Sleeve

3-1/4" Idler Pulley

3/8" x 7/8" OD Washer

3/8-16 x 2-1/2" S.H.C.S.

#10-32 x 1/2" S.H.C.S.

#10-32 x 1/2" S.H.C.S.

#10-32 x 1/2" S.H.C.S.

