

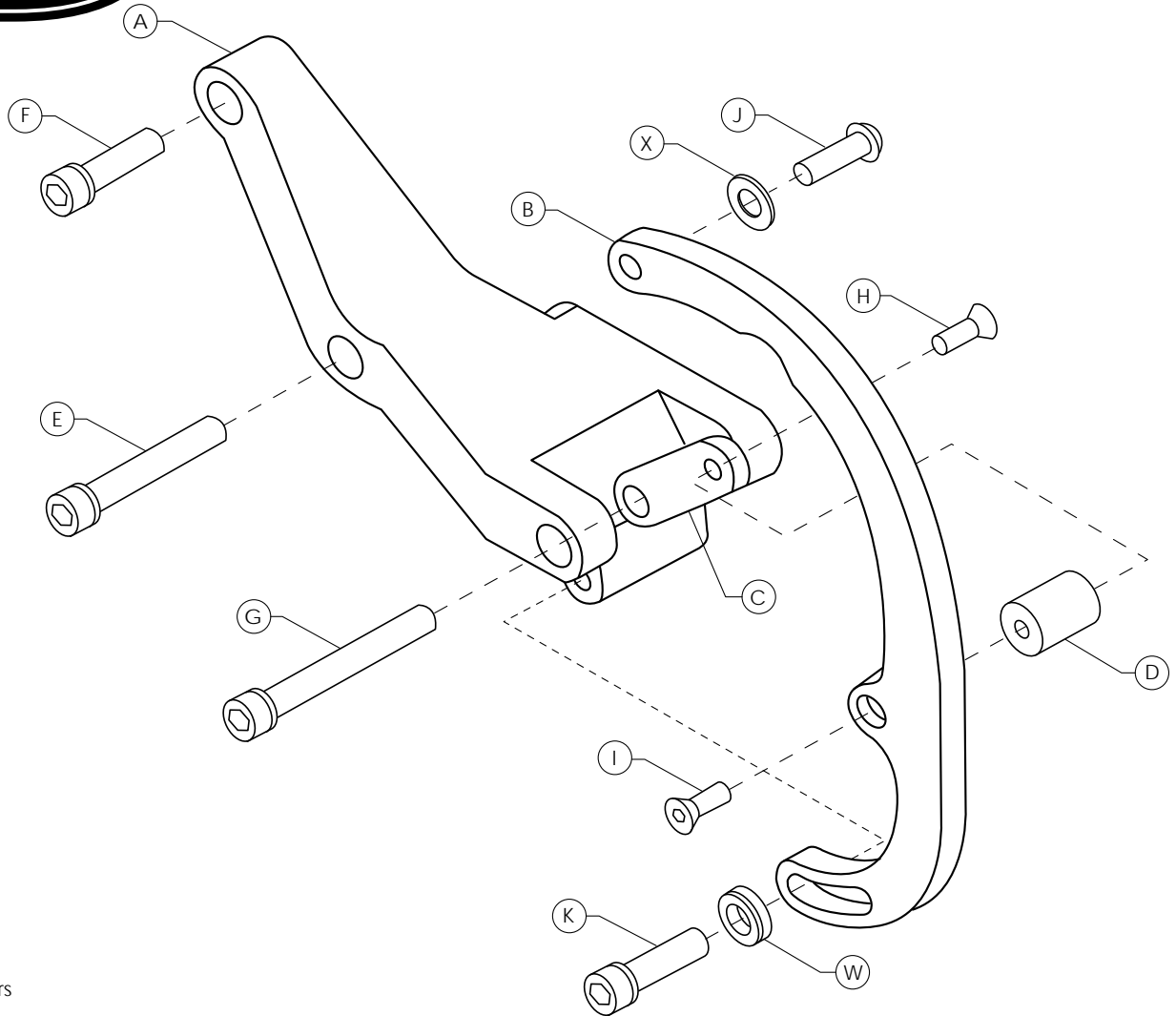

#10420 Alternator Bracket Mount Instructions Side Mount - Driver Side



For use with:

- Chevy small block
- Short water pump
- GM 60 to 80 amp alternators

1. Use Loctite® removable threadlocker 242 (blue) on all fasteners.
2. Bolt alternator bracket [A] to drivers side head using bolts [E] 3/8-16 x 2" SHCS and [F] 3/8-16 x 1-1/4" SHCS. Tighten.
3. Bolt alternator to bracket [A] using bolt [G] 3/8-16 x 3" SHCS. Be sure to position alternator pivot bracket [C] between back of alternator and rear ear of alternator bracket, shim if necessary*. Do not fully tighten.
4. Bolt picot bracket threaded bushing [D] to alternator pivot bracket using bolt [H] 1/4-20 x 3/4" FHCS.
5. Bolt alternator adjustment arm [B] to alternator using bolt [J] 5/16-18 x 1" BHCS and to threaded busing using bolt [I] 1/4-20 x 3/4" FHCS. Tighten.
6. Bolt alternator adjustment arm [B] to lower ear on bracket [A] using bolt [K] 3/8-16 x 1-1/4" SHCS and load washer [W]. Do not fully tighten.
7. Install alternator belt on rear groove when using 2-groove pulleys.
8. Apply tension on alternator belt and tighten bolts [G] 3/8-16 x 3" SHCS and [K] 3/8-16 x 1-1/4" SHCS.

*Shims are provided to shim alternator to bracket for a tight fit. Alternator mounting boss may vary due to polishing or plating.

BILL OF MATERIALS

ITEM	QTY.	DESCRIPTION	SIZE
A	1	Alternator Main Bracket	
B	1	Alternator Adjustment Arm	
C	1	Alternator Pivot Bracket	
D	1	Adjustment Arm To Pivot Bracket Threaded Bushing	
E	1	3/8"-16 Socket Head Cap Screw	2"
F	1	3/8"-16 Socket Head Cap Screw	1-1/4"
G	1	3/8"-16 Socket Head Cap Screw	3"
H	1	1/4"-20 Flat Head Cap Screw	3/4"
I	1	1/4"-20 Flat Head Cap Screw	3/4"
J	1	5/16"-18 Button Head Cap Screw	1"
K	1	3/8"-16 Socket Head Cap Screw	1-1/4"
W	1	Stainless Load Washer	3/4" X 3/16"
X	2	Stainless Flat Washer	3/4" X .060"
**	2	Stainless Flat Washer (Shims)	3/4" X .032"
**	2	Stainless Flat Washer (Shims)	3/4" X .010"