

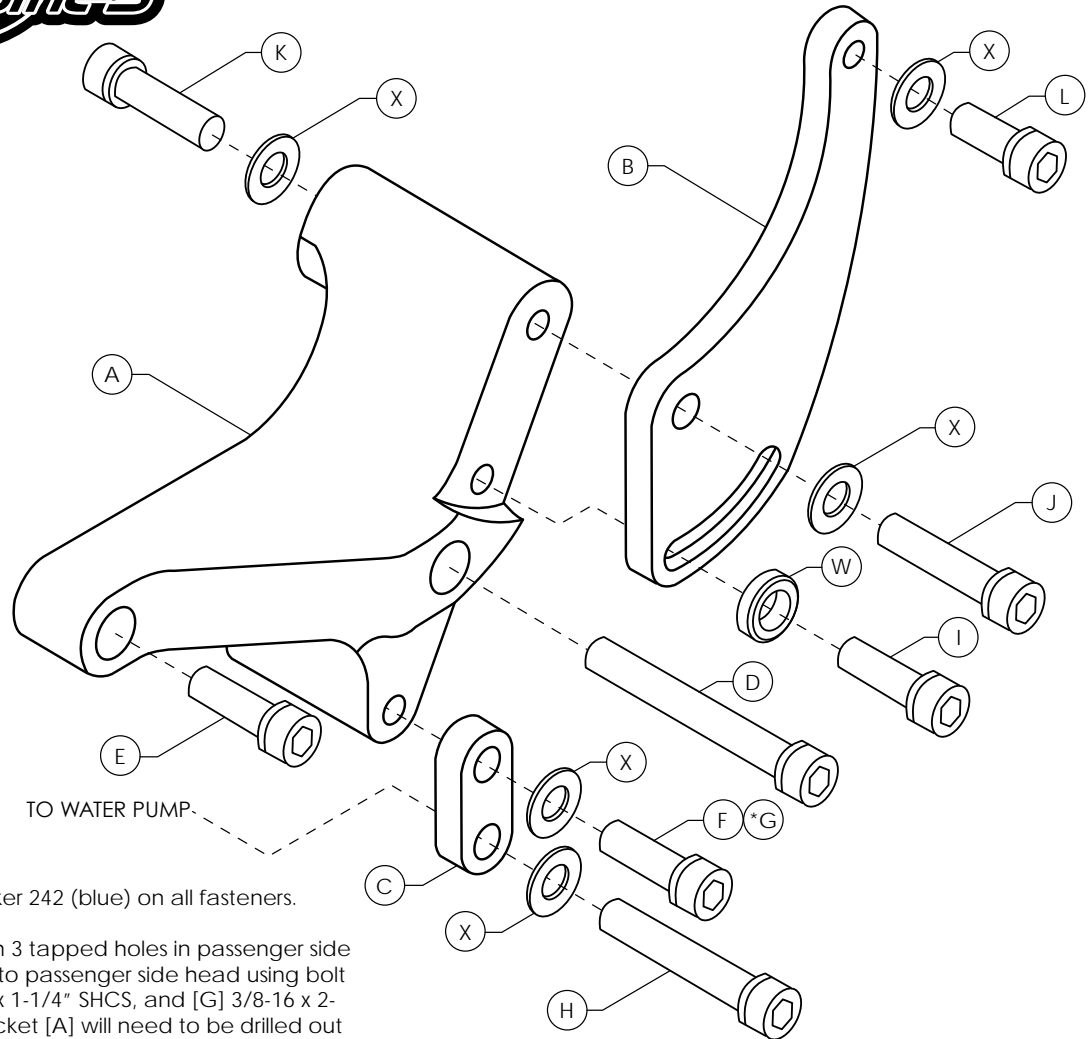

#10221 Compressor Bracket Mount Instructions Top Mount - Passenger Side



For use with:

- Chevy small block
- Short water pump
- Sanden 508 AC compressor

1. Use Loctite® removable threadlocker 242 (blue) on all fasteners.
2. Mounting for late model heads with 3 tapped holes in passenger side head. Bolt compressor bracket [A] to passenger side head using bolt [D] 3/8-16 x 3-1/4" SHCS, [E] 3/8-16 x 1-1/4" SHCS, and [G] 3/8-16 x 2-1/4" SHCS. Hole location [G] in bracket [A] will need to be drilled out with a 25/64" drill bit for this application. No need to use connector bracket [C] for this configuration. Tighten.
3. **Optional mounting on early heads may be required. If not, skip to step 5.** Optional mounting for early heads (Pre 1987) with only 1 drilled & tapped hole on passenger side head. Bolt bracket [A] to head using bolt [E] 3/8-16 x 1-1/4" SHCS. Bolt connector bracket [C] to bracket [A] using bolt [F] 3/8-16 x 1-1/4" SHCS and to water pump using bolt [H] 3/8-16 x 2-1/4" SHCS. Shims may be needed at water pump to compensate for casting variances. Spot drill head at bolt position [D] using 25/64" drill bit to provide adequate start for tap drill. Remove bracket [A] and [C] and drill head using a 5/16" drill bit to a depth of 1". Hand tap head with a 3/8-16 tap to provide at least 3/4" of thread.
4. Reinstall bracket [A] and [C] and shim between bracket [A] and head at bolt location [D] 3/8-16 x 3-1/4" SHCS to compensate for casting variances. Bolt bracket [C] to water pump using bolt [H] 3/8-16 x 2-1/4" SHCS. Shims may be needed at water pump to compensate for casting variances. Tighten bolts [D], [E], [F], and [H].
5. Bolt compressor adjustment arm [B] to inside of the front ear of the Sanden 508 compressor using bolt [L] 3/8-16 x 1" SHCS. Tighten.
6. Bolt Sanden 508 compressor with bracket [B] to bracket [A] using bolt [I] 3/8-16 x 1-1/4" SHCS, [J] 3/8-16 x 11-3/4" SHCS, and [K] 3/8-16 x 1-1/4" SHCS. Do not tighten.
7. Install compressor belt on front groove when using 2-groove pulleys.
8. Apply tension on compressor belt and tight bolts [I] 3/8-16 x 1-1/4" SHCS, [J] 3/8-16 x 11-3/4" SHCS, and [K] 3/8-16 x 1-1/4" SHCS.

* Denotes optional mounting sequence. See instructions for details.

BILL OF MATERIALS			
ITEM	QTY.	DESCRIPTION	SIZE
A	1	Compressor Main Bracket	
B	1	Compressor Adjustment Arm	
C	1	Water Pump To Main Bracket Connector Bracket	
D	1	3/8"-16 Socket Head Cap Screw	3-1/4"
E	1	3/8"-16 Socket Head Cap Screw	1-1/4"
F	1	3/8"-16 Socket Head Cap Screw	1-1/4"
G	1	3/8"-16 Socket Head Cap Screw	3-1/4"
H	1	3/8"-16 Socket Head Cap Screw	2-1/4"
I	1	3/8"-16 Socket Head Cap Screw	1-1/4"
J	1	3/8"-16 Socket Head Cap Screw	11-3/4"
K	1	3/8"-16 Socket Head Cap Screw	1-1/4"
L	1	3/8"-16 Socket Head Cap Screw	1"
W	1	Stainless Load Washer	3/4" x 3/16"
X	6	Stainless Flat Washer	3/4" x .060"
**	2	Stainless Flat Washer (Shims)	3/4" x .032"
**	2	Stainless Flat Washer (Shims)	3/4" x .010"