

#10220 Alternator Bracket Mount Instructions
Top Mount - Drivers Side

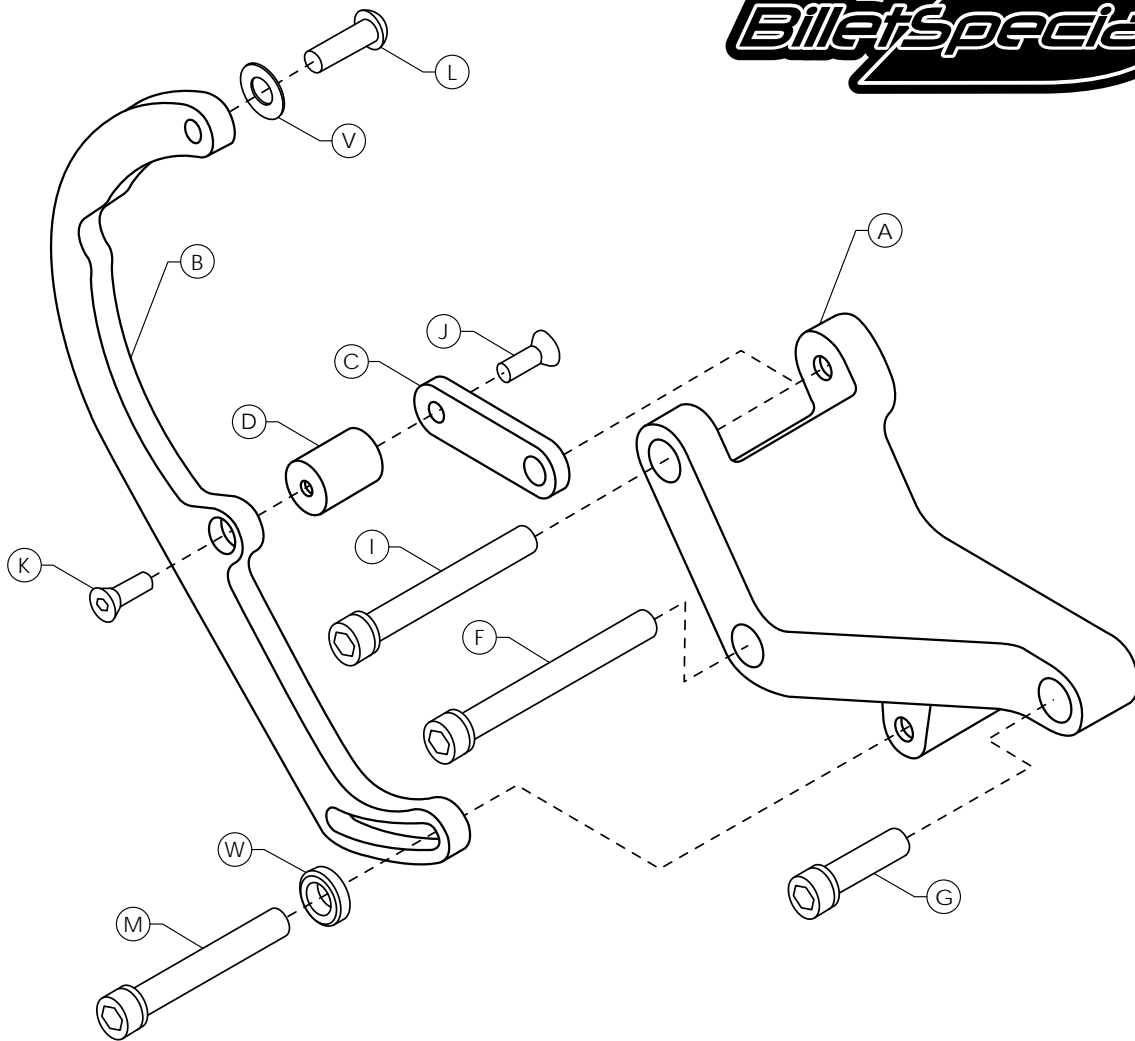

For use with:

- Chevy small block
- Short water pump
- GM 60 to 80 amp alternator

1. Use Loctite® removable threadlocker 242 (blue) on all fasteners.
2. Bolt alternator bracket [A] to drivers side head using bolt [F] 3/8-16 x 3-1/4" SHCS and [G] 3/8-16 x 1-1/4" SHCS. Tighten.
3. Bolt alternator to bracket [A] using bolt [I] 3/8-16 x 3" SHCS. Be sure to position alternator pivot bracket [C] between back of alternator and rear ear of alternator bracket. Shim if necessary at front of alternator boss for proper fit. Do not fully tighten.
4. Bolt pivot bracket threaded bushing [D] to alternator pivot bracket [C] using bolt [J] 1/4-20 x 3/4" FHCS. Tighten.
5. Bolt alternator adjustment arm [B] to alternator using bolt [L] 5/16-18 x 1" BHCS and [V] 5/16" flat washer; and to threaded bushing using bolt [K] 1/4-20 x 3/4" FHCS. Tighten.
6. Bolt alternator adjustment arm [B] to lower ear on bracket [A] using bolt [M] 3/8-16 x 2-1/2" SHCS and load washer [W]. Do not fully tighten.
7. Install alternator belt on rear groove when using 2-groove pulleys.
8. Put tension on alternator belt and tighten bolts [I] 3/8-16 x 3" SHCS and [M] 3/8-16 x 2-1/2" SHCS.

* Shims provided to shim alternator to bracket for a tight fit. Alternator mounting boss may vary due to polishing or plating.

BILL OF MATERIALS			
ITEM	QTY.	DESCRIPTION	SIZE
A	1	Alternator Main Mounting Bracket	
B	1	Alternator Bracket Adjustment Arm	
C	1	Alternator Pivot Bracket	
D	1	Adjustment Arm To Pivot Bracket Threaded Bushing	
F	1	3/8"-16 Socket Head Cap Screw	3-1/4"
G	1	3/8"-16 Socket Head Cap Screw	1-1/4"
I	1	3/8"-16 Socket Head Cap Screw	3"
J	1	1/4"-20 Flat Head Cap Screw	3/4"
K	1	1/4"-20 Flat Head Cap Screw	3/4"
L	1	5/16"-18 Button Head Cap Screw	1"
M	1	3/8"-16 Socket Head Cap Screw	2-1/2"
V	1	Stainless Flat Washer	11/16" x 3/16"
W	1	Stainless Load Washer	3/4" x 3-16"
X	3	Stainless Flat Washer	3/4" x .060"
**	2	Stainless Flat Washer	3/4" x .032"
**	2	Stainless Flat Washer	3/4" x .010"