



3026/0,3

3026/0,5

3026/1,0



INSTRUCTIONS FOR USE

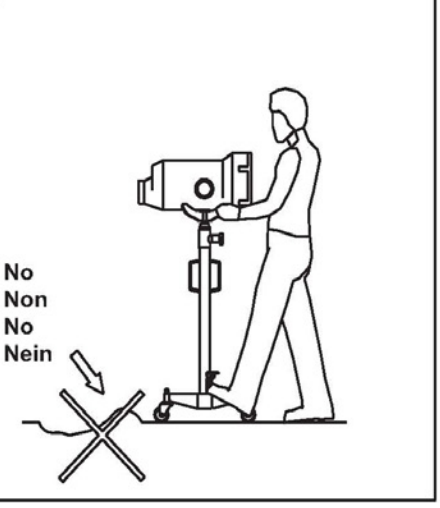
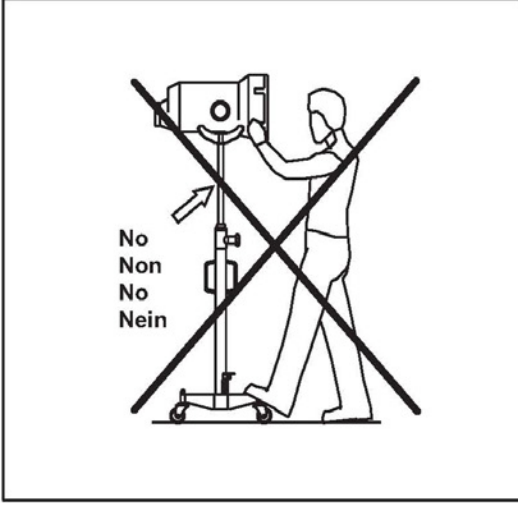
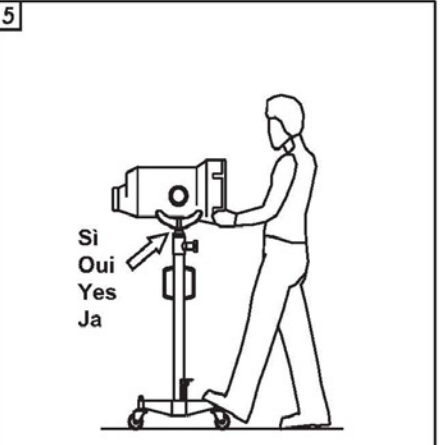
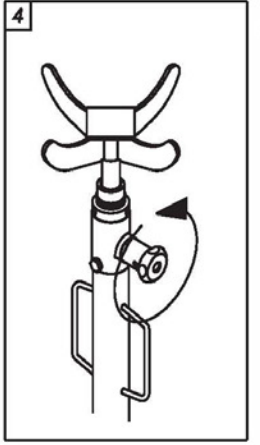
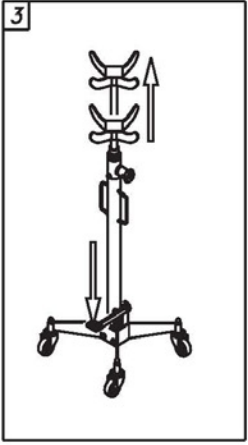
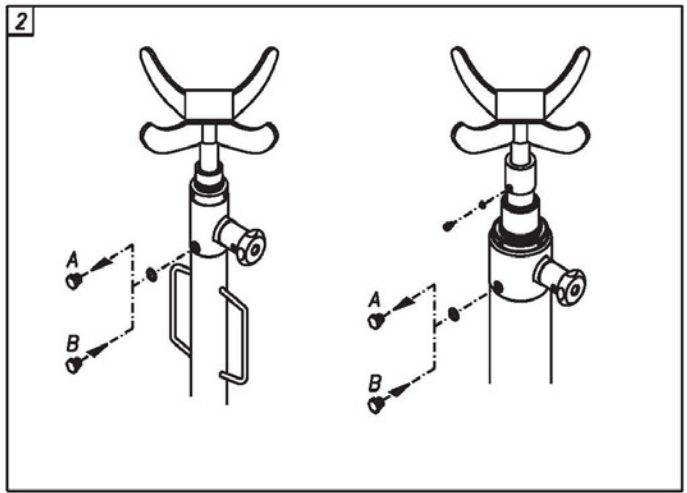
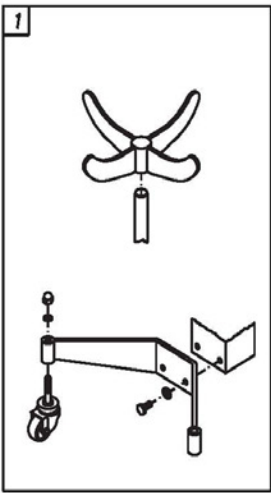

INSTRUCTIONS FOR USE

SERVICE INSTRUCTIONS FOR VERTICAL TRANSMISSION JACKS

RESPONSIBILITY OF THE OWNER AND/OR THE MACHINE OPERATOR

These instructions are an essential part of the jack and must always follow it, even in case of sale. The owner and/or the operator shall understand the product operating instructions and warnings before operating the jack .

If the operator is not fluent in one of these languages, the product instructions and warnings shall be read and discussed with the operator in the operator's native language, making sure that he understands its contents.

The constructor is not liable for damages to people or things due to unfit or unallowed use of the jack.

ASSEMBLING

- Open the package while checking that the machine has not suffered any damages in transit and that all pieces in the packing list are present.
The packing material is to be recycled or used again.
- Apply the 4 pivoting wheels to the 2 trolley ends and block them locking the nut and washer (fig.1).
- Fix, without locking, the 2 trolleys down to the pump by mean of hexagonal-head screws and relative washers (fig. 1). Lock the carriages bolts to the jack only after checking that the outside rod is set at right angles to an horizontal plane.
- Insert the saddle on the rod end.
- Before operating the jack , replace the oil plug (ref.A, fig.2) on the cylinder with the holed one (ref.B, fig.3) supplied by the manufacturer.
- Test the JACK lifting first without load then with the rated load. (ATTENTION! Respect the load capacity shown on the jack.)

OPERATION

Lifting : Pump on the pedal of the jack by a foot (fig.3)

Lowering : turn slowly the release valve to the left. (fig. 4).

SAFETY RULES

The use of this jack is limited to the removal and installation of transmissions and differentials.

When loaded, the transmission jack may be used on a short flat way **AND ONLY WITH THE JACK IN THE LOWEST POSITION, WITH THE ROD COMPLETELY INSIDE** (fig.5). Check that during trasport the load do not swing and suddently fall.

- Do not overload! Overloading may cause damages to persons or things.
- It may be used with appropriate adaptors manufactured especially for the Jack to handle other components , such as rear axle units and transfer cases , within the weigth limitations specified .
- Be sure that the vehicle is appropriately supported before starting repairs..



AVOID DECENTRAL PLACEMENT OF THE GRAVITY OF THE LOAD.

Decentral placement of the load might cause overturning of or damage to the Jack .

- This jack is designed for use only on hard level surfaces capable of sustaining the load, Use on other than hard level surface can result in jack instability and possible loss of load (fig.5).
- The safety valve is calibrated and sealed by the manufacturer; it is absolutely forbidden to tamper with this valve or change its calibration.

FAILURE TO HEED THESE WARNINGS may result in loss of the load, damage to the jack and/or failure resulting in personal injury or property damage.

INSTRUCTIONS FOR USE

MAINTENANCE

The hydraulic system (pump/cylinder) is a sealed system, that requires only a monthly oiling of the moving parts. In case the hydraulic unit leaks oil or has to be dismantled for gaskets replacement, you need to make the pump working and slowly add oil through the filling hole. When the transmission jack is in the lowest position, the oil level should not exceed the filling cap level. For dismantling apply to authorized people.

Required quantity of oil: 0,95 lt.

The hydraulic system contain enough oil when the jack reaches the highest position.



WARNING

a surplus of oil might cause troubles.

Usable oil: any hydraulic oil of gradation ISO 22 (ref. Shell Tellus oil 22 or equivalent) . **NEVER USE BRAKE FLUID.**

Oil the pedal mechanical parts every 2 months with an high quality oil and grease the head pumping element.

In case of oil leaking from the hydraulic system replace the seals.

INSPECTIONS

- Before using, each jack should be checked to exclude leaks, damages, missing, loose and worn parts.
- Each jack shall be inspected immediately if it is believed to have been subjected to an abnormal load or shock.

IT IS RECOMMENDED that this inspection be made by supplier's skilled personnel It is recommended that an annual inspection of the jack be made by a supplier's authorized specialist and that defective and dangerous parts must be replaced with original spare parts supplied by the manufacturer (see spare parts list).

DAMAGED JACKS

Every damaged, very used or abnormally operating jack **SHALL BE REMOVED FROM SERVICE..**

JACKS DESTRUCTION

When the jack must be destructed, materials must be recycled according to the country law in force.