



1471M/C22

Operation manual and instructions

# OPERATION MANUAL AND INSTRUCTIONS

## PNEUMATIC TOOL FOR PUSHING BACK AND ROTATING RIGHT AND LEFT DISC BRAKE CALLIPER PISTONS ITEM 1471M/C22

### OPERATION MANUAL AND INSTRUCTIONS FOR PNEUMATIC TOOL MANUFACTURED BY:

BETA UTENSILI  
S.P.A.

Original documentation drawn up in ITALIAN.

#### CAUTION



IMPORTANT! READ THIS MANUAL THOROUGHLY BEFORE USING THE PNEUMATIC TOOL. FAILURE TO COMPLY WITH THE SAFETY STANDARDS AND OPERATING INSTRUCTIONS MAY RESULT IN SERIOUS INJURY.



Store the safety instructions with care and hand them over to the users.

#### PURPOSE OF USE

- **The pneumatic tool can be used for the following purposes:**
  - Pushing back and rotating disc brake calliper pistons
  - Right-hand and left-hand operation
  - Can also be used in open places exposed to water and air
- **The pneumatic tool must not be used for the following operations:**
  - The pneumatic tool must not be used in environments containing potentially explosive atmospheres.
  - The trigger must not be locked with adhesive tape or clamps.
  - The pneumatic tool must not be used for any applications other than stated ones.

#### WORK AREA SAFETY

- Beware of both surfaces that may become slippery due to the use of the machine and the danger of tripping over the air hose.

-  Do not operate the pneumatic tool in environments containing potentially explosive atmospheres, because sparks may be generated, which can ignite the dust, fumes or gases.
-  Avoid contact with live equipment: the pneumatic tool is not insulated, and contact with live parts can cause electric shocks.
-  Keep children and bystanders away from your workplace while operating the pneumatic tool. Distractions from other people can cause you to lose control over the pneumatic tool.

#### PNEUMATIC TOOL SAFETY

- Do not point the air flow to yourself or other people. Compressed air can cause serious injury.
- Check the connections and the air supply lines. All units, couplers and hoses should conform to the product specifications in terms of pressure and air volume. Too low pressure impairs the function of the pneumatic tool; too high pressure can cause damage and/or injury.
- Do not bend or tighten any hoses; avoid using solvents and sharp edges. Keep the hoses away from heat, oil and rotating parts. Immediately replace any damaged hose. A defective feed pipe may cause uncontrolled movements of the compressed air pipe. Raised dust or chips may cause eye injury. Make sure that the hose clamps are always secured firmly.

#### PERSONNEL SAFETY

- Stay alert; watch what you are doing. Do not use the pneumatic tool while tired or under the influence of drugs, alcohol, or medication.
- **Always use the following personal protective equipment:**
  - Eye protection
  - Safety shoes
  - Protective gloves against physical agents

# OPERATION MANUAL AND INSTRUCTIONS

- Make sure you are in a safe position, keeping proper balance at all times. A safe working position and a proper body posture enable better control of the pneumatic tool in unexpected situations.
- Do not wear loose clothing or jewellery. Keep your hair, clothing and gloves away from moving parts. Loose clothing, jewellery, and long hair can get caught in moving parts.
- Do not directly inhale the exhaust air, and prevent it from getting into your eyes. The exhaust air of the pneumatic tool can contain water, oil, metal particles and impurities, which may cause hazards.

## PNEUMATIC TOOL USE AND CARE



- Do not overload the pneumatic tool. Use the pneumatic tool intended for your work only.
- Always check that the machine is free from defects. Do not use a pneumatic tool that has a defective On/Off switch. A pneumatic tool that can no longer be stopped or started is dangerous and must be repaired.
- Store idle pneumatic tools out of the reach of children. Do not allow persons unfamiliar with these instructions to operate the pneumatic tool.
- Maintain the pneumatic tool with care. Check for misalignment or binding of moving parts, breakage or damage of parts and any other condition that may affect the operation of the pneumatic tool. Have damaged parts repaired before using the pneumatic tool.
- Do not modify the pneumatic tool. This can reduce the effectiveness of safety measures and increase operator risk.
- Have the pneumatic tool repaired only through a trained repair person and only using original replacement parts.

## PNEUMATIC TOOL SAFETY

- Make sure that the nameplate is readable; get a replacement nameplate from the manufacturer, if need be.
- Operators and maintenance personnel should be physically able to handle the weight and power of the pneumatic tool.
- Avoid contact with the moving parts of the tool, as this may cause injuries.
- Stop the tool in case of air supply failure or low operating pressure. Check the operating pressure; start the tool again when optimal operating pressure is resumed.
- Hold the pneumatic tool with a not too firm yet secure grip, compliant with the required hand reaction forces.
- Never carry the pneumatic tool by the hose.

## PERSONAL PROTECTIVE EQUIPMENT TO WEAR WHILE OPERATING PNEUMATIC TOOL

-  Failure to observe the following warnings may result in physical injury and/or disease.

	ALWAYS WEAR EYE PROTECTION WHILE OPERATING PNEUMATIC TOOL OR PERFORMING MAINTENANCE JOBS
	ALWAYS WEAR PROTECTIVE GLOVES AGAINST PHYSICAL AGENTS WHILE OPERATING PNEUMATIC TOOL
	ALWAYS WEAR SAFETY SHOES

-  Additional personal protective equipment to wear according to the values found in the environmental hygiene/risk analysis survey if the values exceed the limits under current regulations.

	WEAR PROTECTIVE MASK AGAINST PHYSICAL AGENTS ACCORDING TO THE VALUES FOUND IN THE ENVIRONMENTAL/INDUSTRIAL HYGIENE SURVEY
---	---

# OPERATION MANUAL AND INSTRUCTIONS

## TECHNICAL DATA

AIR INLET	1/4" GAS
MINIMUM HOSE SIZE $\varnothing$	6,0 mm
MAXIMUM PRESSURE	8,0 bar
THRUST CAPACITY	150 kg
PISTON	$\varnothing$ 50 mm
ROD	$\varnothing$ 14 mm
PISTON STROKE	45 mm
WEIGHT	1,3 kg
LENGTH	260 mm
HEIGHT	190 mm
WIDTH	95 mm
NOISE (ISO 15744)	
SOUND POWER LEVEL	$L_{WA} = 57,0$ dB
SOUND PRESSURE LEVEL	$L_{pA} = 68,0$ dB
VIBRATIONS (ISO 20643)	
VIBRATION LEVEL	$0,876$ m/s <sup>2</sup>
UNCERTAINTY	$K=0,582$ m/s <sup>2</sup>

## KEY TO SYMBOLS

- 1: magnetic end
- 2: release button
- 3: rotation lever
- 4: operation lever
- 5: oil lubricator

## Air supply connection

For correct use of the pneumatic tool, always keep to a maximum pressure of 8 bar, as measured at the tool inlet. Feed the pneumatic tool with clean, condensate-free air (picture). Excessively high pressure or humidity in supply air results in shorter life for the mechanical parts and may damage the tool.

## USE

Choose the adapter according to the type of brake calliper piston.

Fit it onto the magnetic end (1) of the tool.

Connect the pneumatic tool to the compressed air line, making sure that it does not exceed a maximum pressure of 8 bar.

Press release button (2) and operate lever (3) to move the push rod forward or backward, so that the tool can be fitted into the brake calliper.

Do not place any parts of the body between the tool and the brake calliper, to avoid crushing.

Press trigger (4), while rotating lever (3), to rotate the brake calliper piston.

After pushing the piston backward, press release button (2) and pull lever (3) to move the push rod backward, thereby releasing the tool from the calliper.

Periodically, depending on the frequency of use, clean the tool, to remove any impurities and allow for proper operation. Furthermore, lubricate the piston, adding a few drops of hydraulic oil (5).

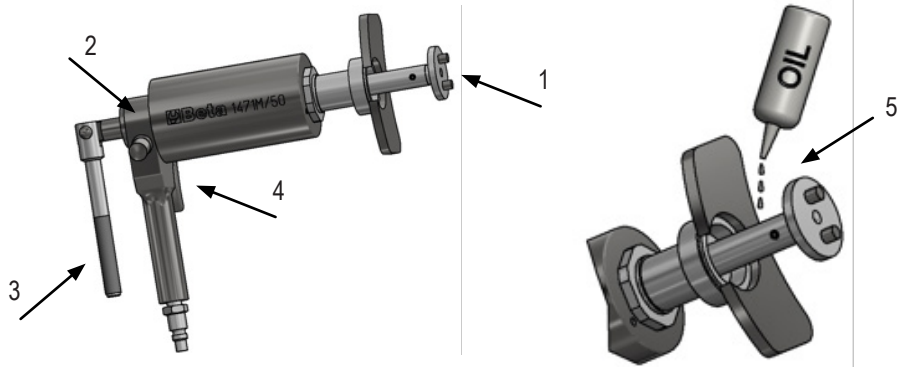

# OPERATION MANUAL AND INSTRUCTIONS

Always disconnect the air supply before replacing the adapters.

## INFORMATION ON ADAPTERS

0 - GM	A - Renault
2 - Citroen, Honda	B1 - Ford
3 - VW, Land Rover	B2 - Iveco Daily
4 - Alfa Romeo, FIAT, FORD, GM, HONDA, MAZDA, SAAB, TOYOTA,	B3 - BMW
5 - Adattatore da 3/8"	B4 - BMW
6 - NISSAN, VW	B5 - Mini / BMW
7 - Alfa Romeo, Audi, Citroen, FIAT, FORD, HONDA, Jaguar, Lancia, NISSAN, PEUGEOT, Renault, Rover, SAAB, Seat, SUBARU, TOYOTA, VW, Volvo	E - FORD, NISSAN
8 - GM	F - Opel
9 - GM	M - FORD, MINI
N - Alfa Romeo, Audi, Lancia, SAAB, Honda, VW	
K - Citroen	
W - Passat VW	

## LUBRICATION

The pneumatic tool must be connected to a filter-lubricator unit (we recommend Beta item 1919F1/4) provided with an air-oil microfog mixer, set at two drops per minute. This will result in a high-performing tool and wear-resistant mechanical parts. If lubrication is not provided to the line, oil ISO 32 must be periodically poured into the pneumatic tool, through the air supply hole.

## MAINTENANCE

Maintenance and repair jobs must be carried out by trained personnel only. For such jobs, you can contact Beta Utensili S.P.A.'s repair centre through your Beta dealer.

## DISPOSAL

The pneumatic tool, accessories and packaging should be sent to a waste disposal centre, in accordance with the laws in force in your country.

## WARRANTY

This tool is manufactured and tested in accordance with current EU regulations, and is covered by a 12-month warranty for professional use or a 24-month warranty for nonprofessional use.

We will repair any breakdowns caused by material or manufacturing defects by fixing the defective pieces or replacing them at our discretion.

Should assistance be required once or several times during the warranty period, the expiry date of this warranty will remain unchanged.

This warranty will not cover defects due to wear, misuse or breakdowns caused by blows and/or falls. In addition, this warranty will no longer be valid if any changes are made, or if the pneumatic tool is forced or sent to the customer service in pieces.

This warranty explicitly excludes any damage to people and/or things, whether direct or consequential.

## DECLARATION OF CONFORMITY CE

We hereby declare, assuming full responsibility, that the described product complies with all the relevant provisions of Machine Directive 2006/42/EC and amendments thereto, as well as with the following standard:

- EN ISO 12100