





Installation Instructions



ZipRail Tonneau

No Drilling in Truck Bed Required

Vehicle Application:

- Chevrolet Silverado and Sierra Sportside
6.5' Short Bed
1999 – 2005
Part Number: 15206

INSTALLATION TIME	SKILL LEVEL
 1/2 Hour	 1 - Easy

TOOLS		
 Safety Glasses	 Wrench 1/2"	 Allen Wrench 1/8"

Installation Tips

Before you begin installing this assembly, read all instructions thoroughly.

For a smooth fit:

For ease in installation, the product should be installed at temperatures above 70° F. Below this temperature, the fabric may contract an inch or more, making it difficult to fit to the vehicle. It is normal for fabric to contract and wrinkle when stored in the shipping carton. Within a few days after the installation, the fabric will relax and the wrinkles will disappear.

Wash truck to make sure no dirt or abrasive materials are between your truck's finish and the Tonneau Rail Frame.



CAUTION

Safety glasses should be worn at all times while installing this product.

WARNING

Tonneau cover must be secured at all points when vehicle is moving. A tonneau cover that is unsecured will flap, resulting in damage to the vinyl fabric.

Do not overload bed of truck. Stress on tonneau could result in damage.

ZipRail Tonneau Installation Instructions

Parts List

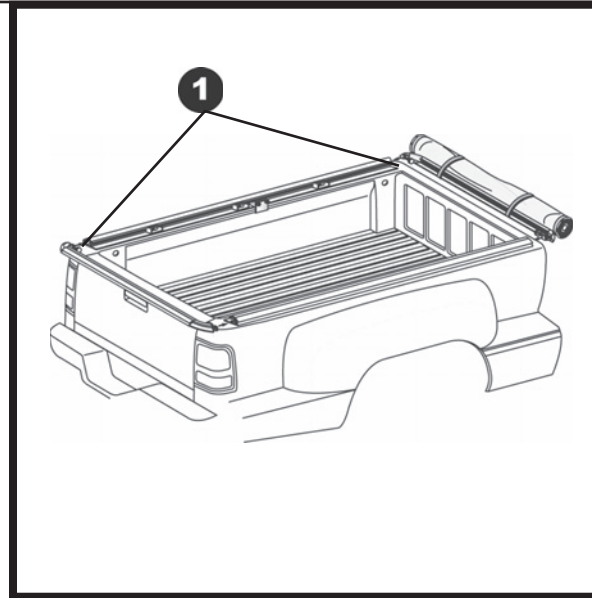
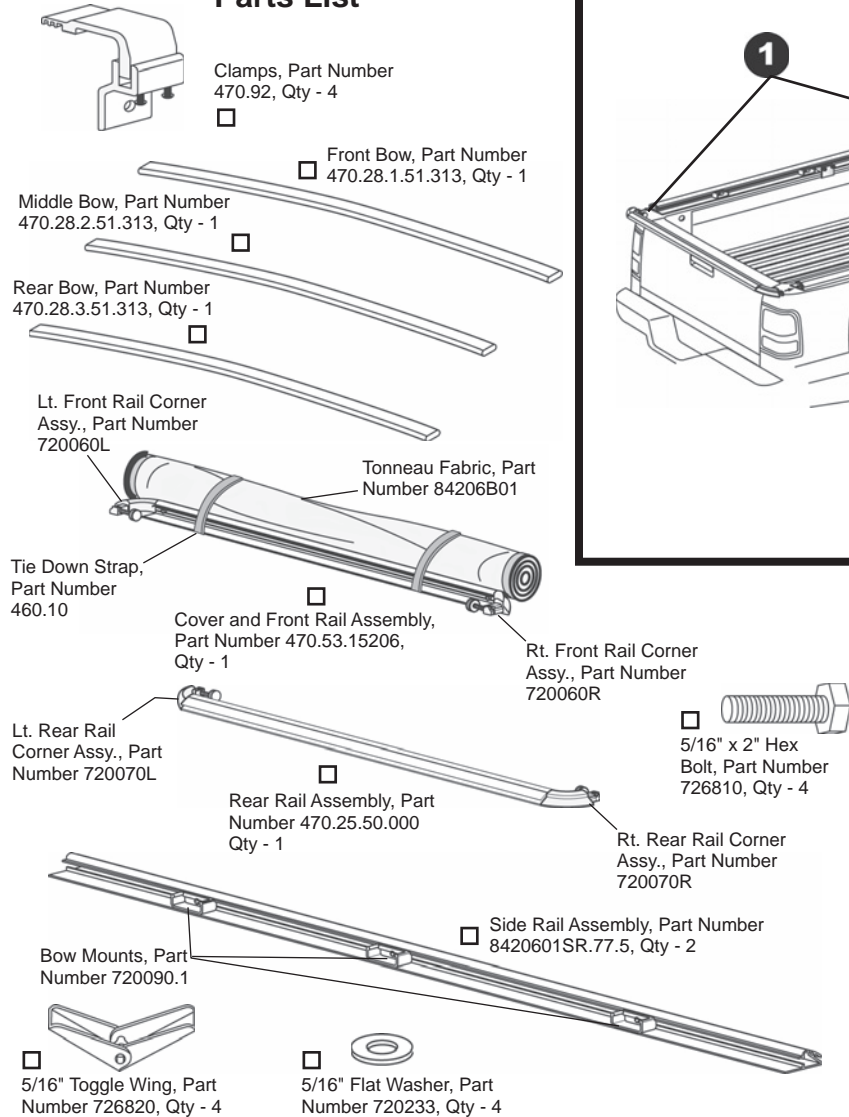

1 Install Rail Assemblies

Locate the Left and Right Side Rails. Remove paper backing and set the Side Rails onto the top of the truck box.

Remove paper backing and set the Front Rail (with cover attached) onto truck. Make sure long ends of Tie Down Straps are to the inside of the truck box. Fasten corners by inserting into Side Rail ends and tightening the thumb screws.

Follow the same procedure to install the Rear Rail.

NOTE If you choose to assemble the frame on a level surface other than the vehicle, use two (2) people to position it on the truck bed to avoid extreme pressure on the corners.

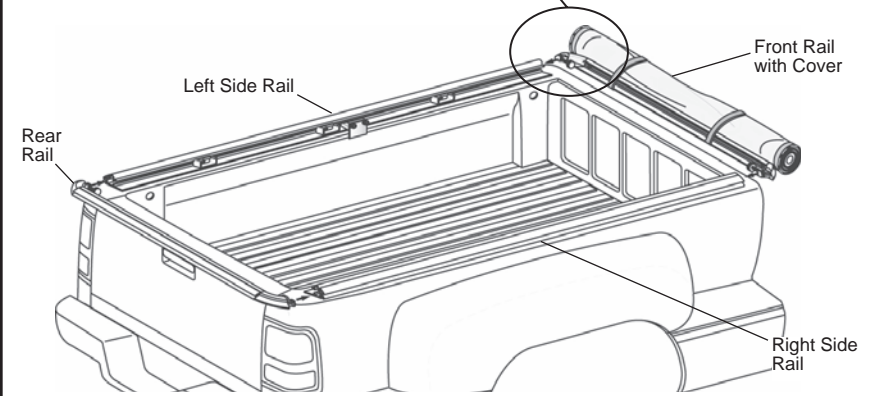
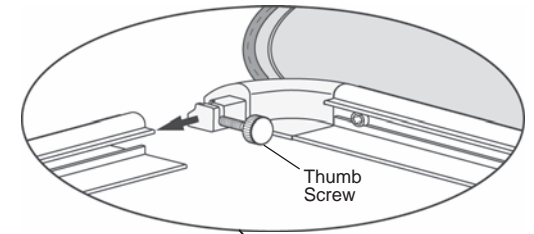

ZipRail Tonneau Installation Instructions

2 Install Outer Clamps

Locate the four Clamps, Toggle Wings, 5/16" Flat Washers and 5/16" x 2" Hex Bolts. Use a 1/8" Allen Wrench to remove the two #10 x 3/4" Screws from the bottom of each clamp and separate the Inner and Outer Clamps.

Slide a 5/16" Flat Washer onto the 5/16" x 2" Bolt. Insert the Bolt through the hole in the Outer Clamp. Thread the Toggle Wing onto the bolt. Compress the wing and insert it into the hole as shown. Tighten the bolt by hand until snug. Slide the Outer Clamp up as far as possible and tighten with a 1/2" wrench.

NOTE You may have to pull the Outer Clamp away from the truck bed so the Toggle Wing does not spin while you turn the bolt.

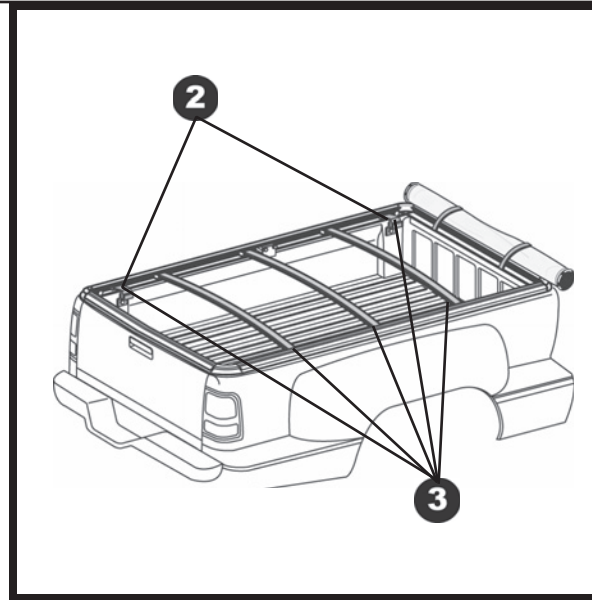
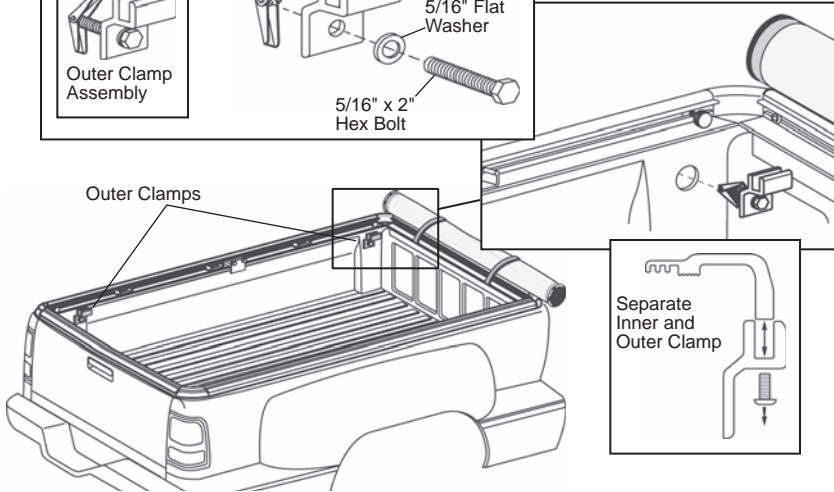
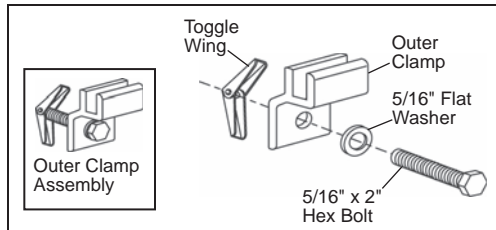

3 Install Inner Clamps and Bows

Locate the three Bows. Place one end of the Front Bow into one of the front bow mounts then snap the other end into place. Repeat with the other two Bows.

Hook the "teeth" of the Inner Clamp to the Side Rail and the bottom into the Outer Clamp as shown. Make sure the frame is square side to side and front to back. Reinstall the #10 x 3/4" Screws into the clamps and tighten with the 1/8" Allen Wrench.

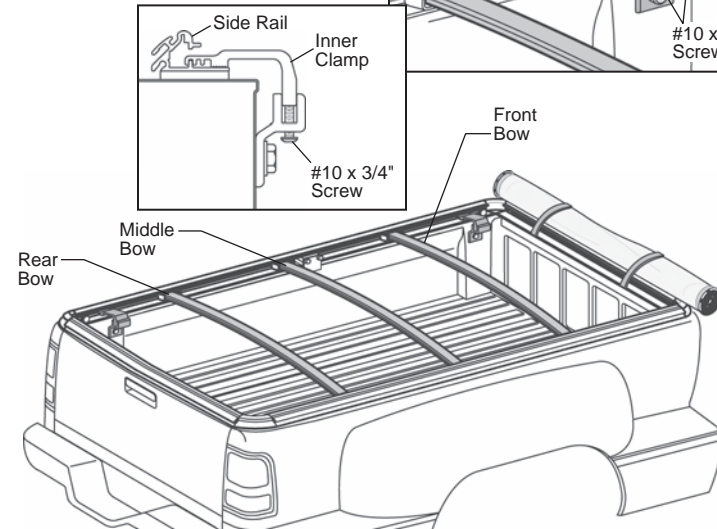
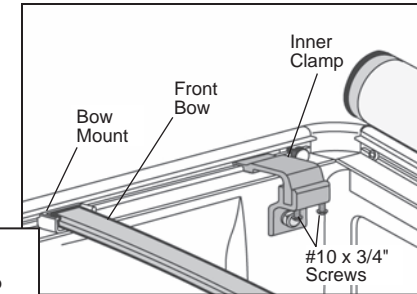

ZipRail Tonneau Installation Instructions

4 Secure the Fabric

Make sure the inside edge of the Front Rail is aligned with the inside edge of the bed and that the Rail Assembly is centered from side to side on the vehicle.

Check that the front strip on the Tonneau Fabric is centered in the Front Rail. If not slide the strip in the rail until it is centered.

The plastic strips along the three sides of the vinyl cover fit into the grooves in the rail assembly.

Pull the cover over the bows to the rear of the truck. Center the fabric tag above the tailgate latch and begin inserting the rear plastic strip into the groove working from the center out to each rear corner.

Use one hand to insert and the other to guide the plastic into the groove. Start at either the front or rear corner to insert the side plastic strip into the groove. Work to the opposite corner. Repeat on both sides.

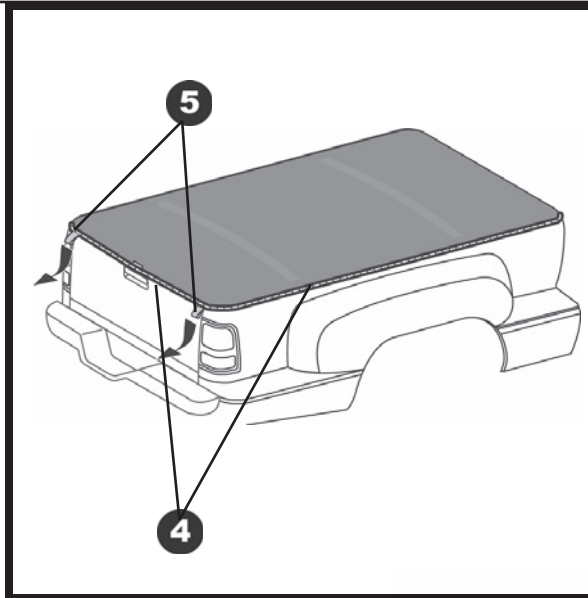

5 Removing Cover

To remove cover: Use the loops at the Right or Left rear corner and ease the plastic strip out of the rail by pulling DOWN and OUT. Then peel the plastic strip out of the remainder of the rear rail. Pull DOWN and OUT on the vinyl fabric to remove the plastic strips from the sides of the rail assembly.

Roll cover toward cab of truck. Use Hook & Loop straps attached to front of rail to secure cover.

To fasten cover, repeat installation step 4.

