

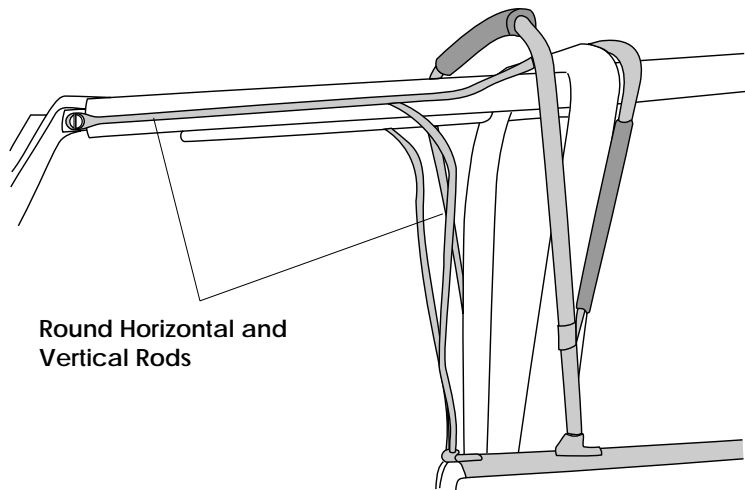

**Bestop**

## Stop! Read This Important Information.



Round Horizontal and Vertical Rods

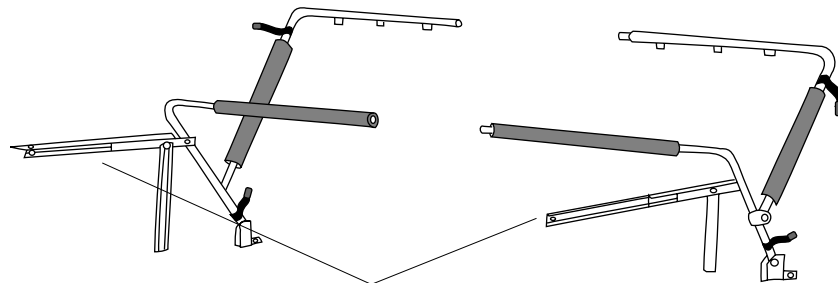

Flat Horizontal Rods

### Stop, Do Not Proceed, Read This

This door replacement kit is designed for the replacement of doors on a Supertop **ONLY!** This door will not work on any other style of soft top.

For this door to work properly, your Supertop **MUST** have round tubular steel Horizontal and Vertical Rods.

If your Horizontal Rods are flat, stamped metal, this door kit will **NOT** work.

Please contact your distributor or Bestop with any questions.



## Supertop Installation Instructions

For: CJ7 (1976-1986) and Wrangler (All) Supertop Door  
Part Number: 51778

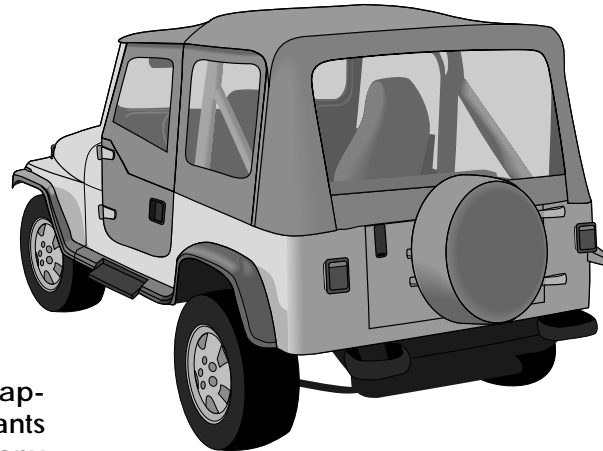

### WARNING

This product is designed primarily to enhance the appearance of the vehicle and to shield the occupants from ordinary weather conditions. Do not rely in any way on the components of this product to contain occupants within the vehicle, or to protect against injury or death in the event of an accident. This top will not protect the occupants from falling objects. Never operate vehicle in excess of manufacturer's specifications.

**WEAR SEAT BELTS AT ALL TIMES**

Read and follow, precisely, all installation instructions provided when installing top. Failure to do so may result in a poor fitting top and could place occupants of the vehicle in a potentially dangerous situation.

### Installation Tips

*Before you begin installing this door assembly, read all instructions thoroughly. Below are a few tips to make this installation easier.*

#### **For a smooth fit:**

It is normal for fabric to contract and wrinkle when stored in the shipping carton. Within a few days after the installation, the top will relax and the wrinkles will disappear.

## Parts List and Hardware Identification

Door, Upper - Right	Qty - 1
Door, Upper - Left	Qty - 1
Door, Lower - Right	Qty - 1
Door, Lower - Left	Qty - 1

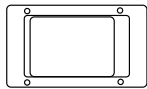

Paddle Handle Assembly,  
Qty - 2, Part Number 245.46



### Tools Needed

1/8" Allen Wrench  
7/16" Wrench  
Phillips Head Screwdriver

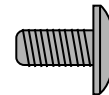

#10-24 Truss Head Machine Screw -  
Black, Qty - 12, Part Number 195.92



#10-24 Locknut, Qty - 12,  
Part Number 195.93

Door Striker - Right, Qty - 1,  
Part Number 212.87

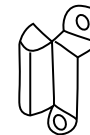

Door Striker - Left, Qty - 1,  
Part Number 212.88



## Step One

If your vehicle has Hard Door Strikers, it will be necessary to remove before installing the Doors. Use a #20 Torx to remove the four bolts in the door striker assembly.

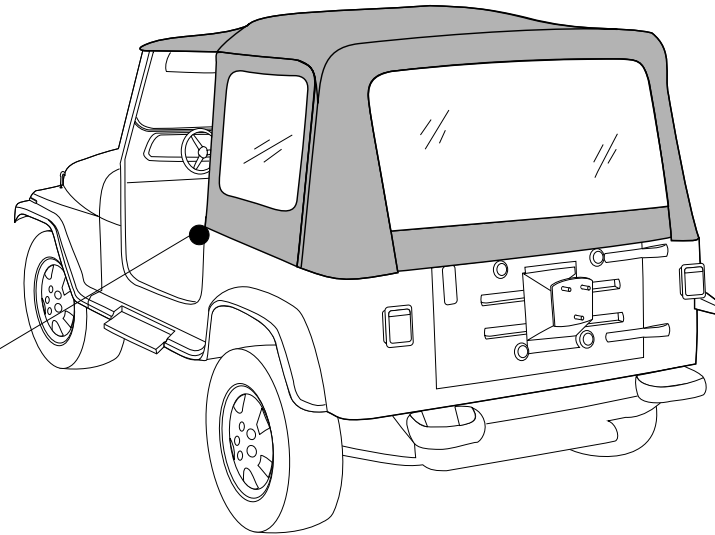
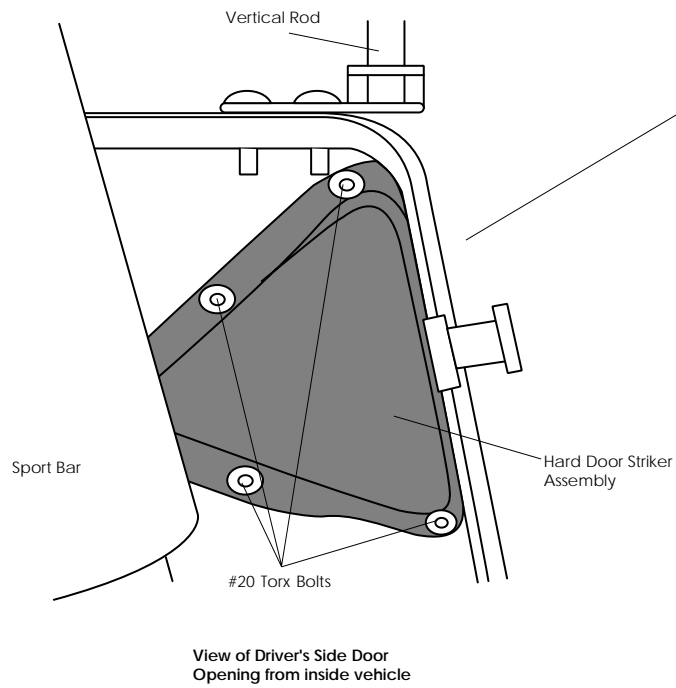

## Step Two

Remove the plastic caps from the upper door pins and from the Lower Door Hinge Pins. Locate the pre-cut "X" in the lower door panel where the Paddle Handle will fit into the mounting plate on the door frame. Fold the pre-cut fabric back and insert the Paddle Handle into the mounting plate so that the latch mechanism is inside of the vehicle and the latch bolt is toward the rear of the door. Align the four holes in the Paddle Handle Assembly with the four holes in the mounting plate. Use a pointed tool to punch four holes in the fabric to match the holes in the Paddle Handle and the mounting plate. Insert four #10-24 Truss Head Machine Screws from the outside and secure them with #10-24 Locknuts. Do not tighten the screws until all four are in place. Trim the excess fabric around the Paddle Handle. Repeat for both lower doors.

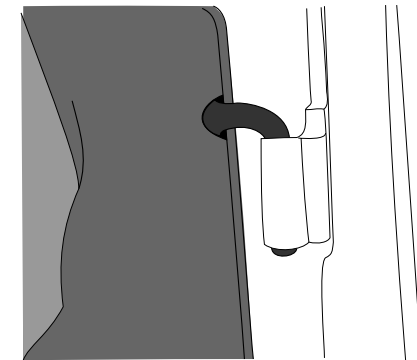
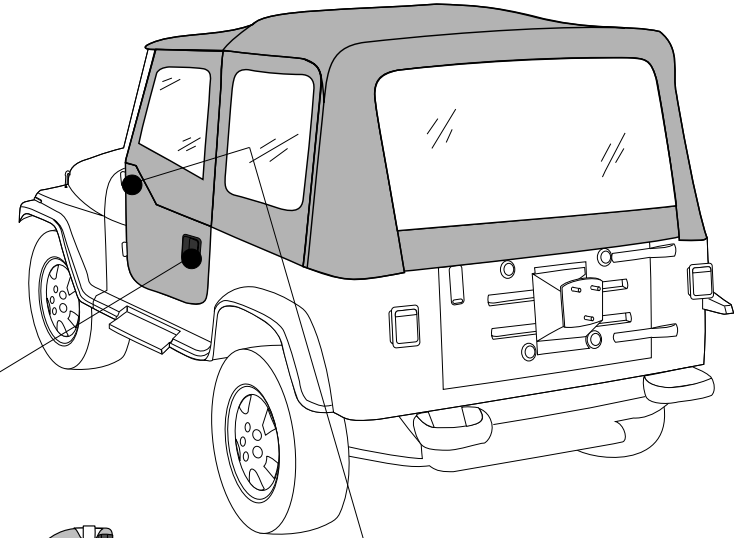
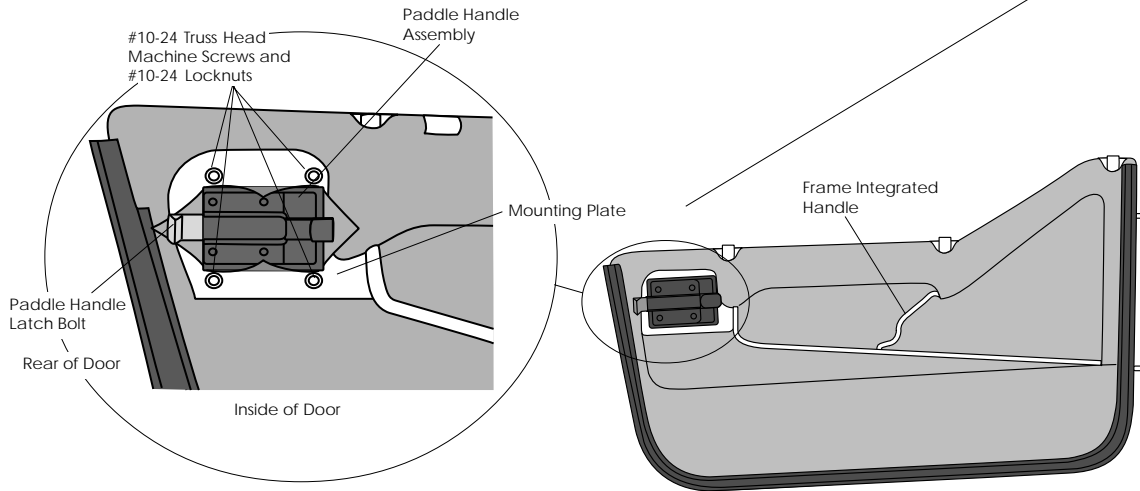

## Step Three

**NOTE:** Bestop has replaced the Clip-On Handle included in this kit with a frame integrated handle. There are no Clip-On Handles in this kit due to this product change. Please disregard this step in the video installation.

**WARNING:** Door handles are only designed to aid in door closure. Door and handle **WILL NOT** support a person's weight.

## Step Four

Hold the door straight out from the vehicle with the hinge pins over the body hinges. Lower the pins into the hinges. Make sure that the pins are fully inserted into the body hinges. Close the door and check all sides to make sure that it fits properly against the body.

## Step Five

Locate the Lower Hinge Pin Adjustment Plate on the Lower Door frame. If the Lower Door needs to be adjusted for a better fit against the body, use a 7/16" Wrench to loosen the two nuts in the adjustment plate. Slide the Hinge Pin backward or forward as necessary for the best fit. Tighten the nuts.

**Note:** The door should fit snugly into the bevel of the door opening.

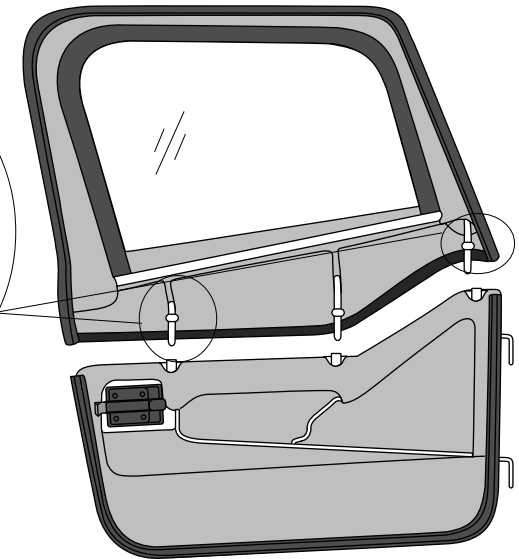
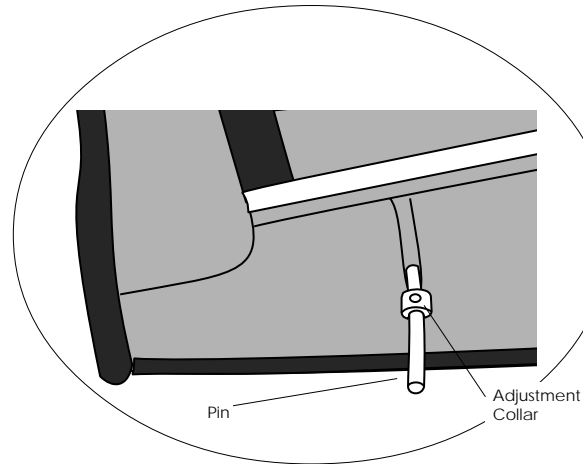
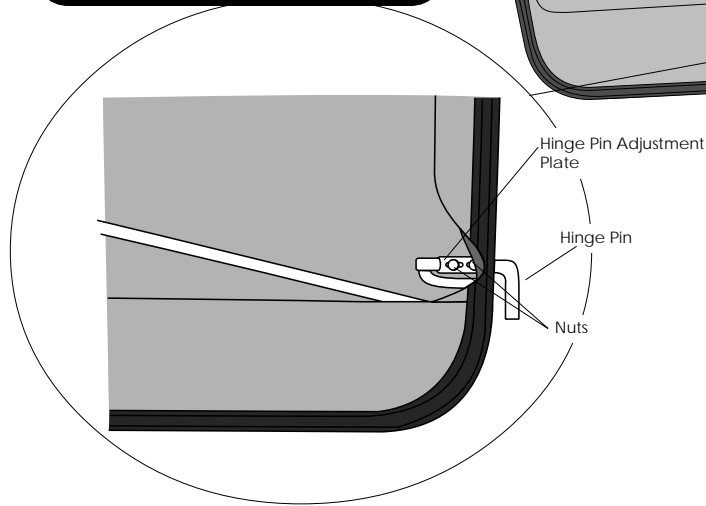
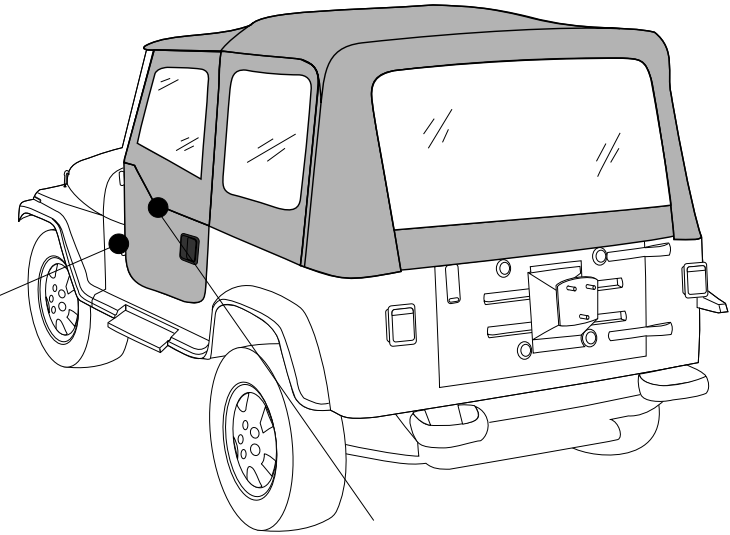
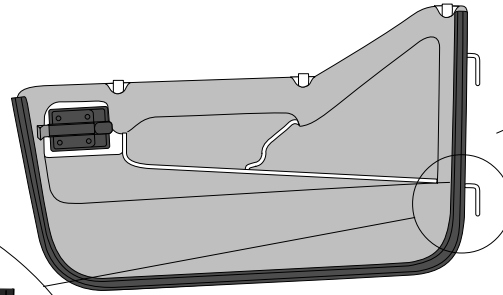

## Step Six

Install the upper door into the lower door. Starting with the front pin, slip the pins into the sockets in the lower door. Make sure that the pins are well seated in the sockets. Close the door to check that it fits properly against the body. If necessary, use a 1/8" Allen Wrench to loosen the Collars on the front and rear upper door pins. The Collars will slide up or down as needed to provide the best fit of the Upper Door against the windshield. Attach the loop strip on the bottom of the upper door to the hook strip on the top of the lower door. If necessary for proper door fit, bend the door slightly.

**Note:** Lubricating the upper door pins with a light weight oil will make it easier to install and remove the upper door.

## Step Seven

Close the door against the body and place the Door Striker behind the Paddle Handle Latch with the flat surface to the inside of the vehicle and with the raised end toward the top. Mark, center punch and drill two 7/32" holes. Install the Door Striker with two #10-24 Truss Head Machine Screws and two #10-24 Locknuts. The Door Striker may be adjusted in or out until you are satisfied with the way the door shuts and opens. Repeat on both sides of the vehicle.

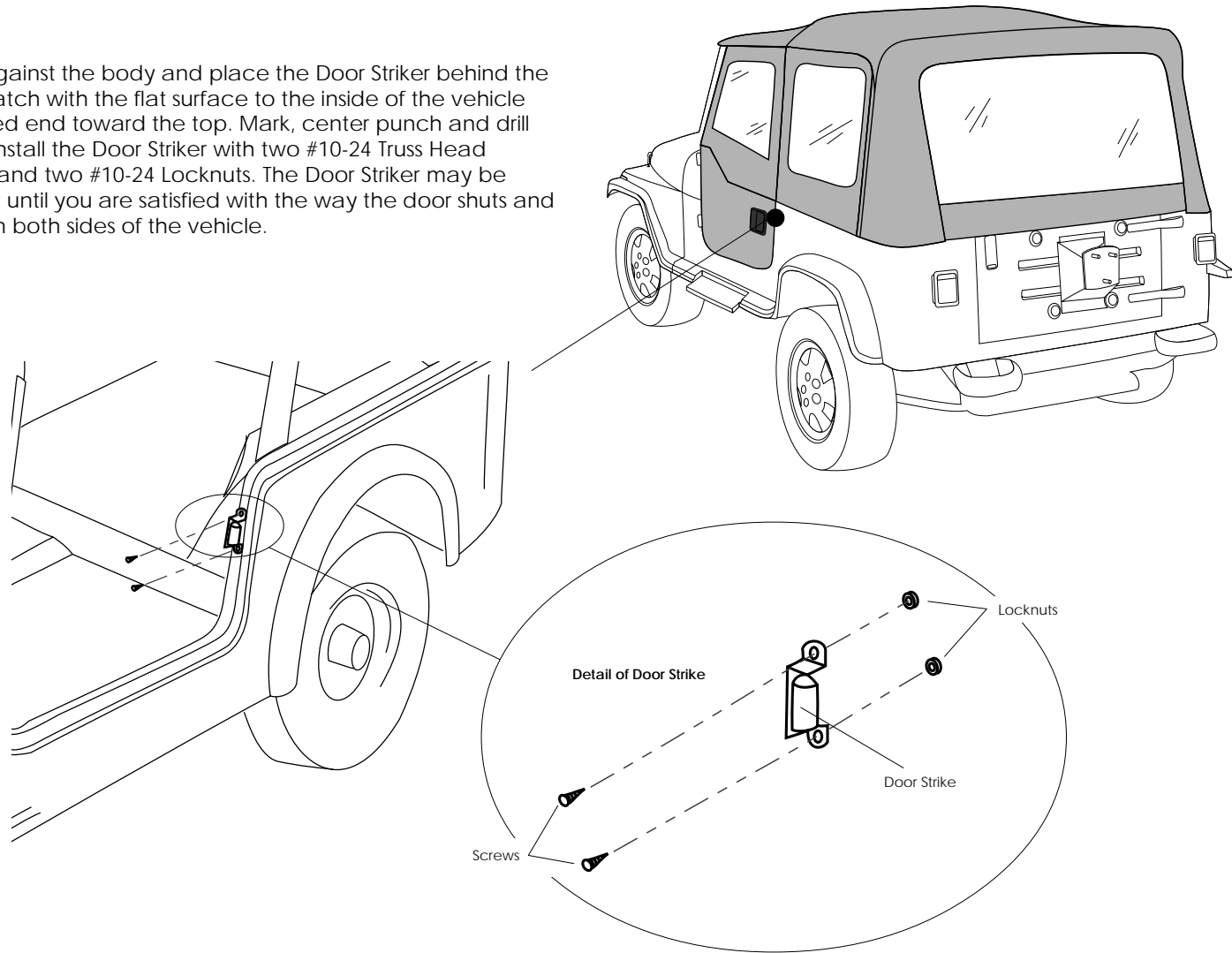

## Care and Maintenance of your Bestop Top

Your top is made of the finest materials available. To keep it looking new and for the maximum possible wear, it will need periodic cleaning and maintenance.

**Washing:** The top fabric should be washed often using soap, warm water and a soft bristle brush. Rinse with clear water to remove all traces of soap. A vinyl protector can be used on the vinyl side of the fabric.

**Windows:** Keep windows clean to avoid scratching. DO NOT use a brush on the windows! Wash with a water-soaked cloth or sponge and a mild dishwashing detergent. NEVER WIPE THE WINDOWS WHEN THEY ARE DRY. Be careful when cleaning snow or frost from the vinyl windows since they are easily scratched and may crack at low temperatures. DO NOT roll the sides or rear window in cold weather. The windows become stiff and will crack.

**Zippers:** Keeping the zipper cleaned and lubricated with a silicone lubricant will help prevent damage and keep the zippers in a smooth working condition. If a zipper opens behind the slider, the slider may have been spread apart.

This problem can usually be repaired by using an ordinary pair of pliers to bring the sides back into parallel. Return slider to the end of the zipper in the normal Open position. Squeeze lightly at first and test the zipper. If the zipper continues to remain open squeeze more firmly with the pliers and try the zipper again. Repeat this procedure until the zipper operates correctly.

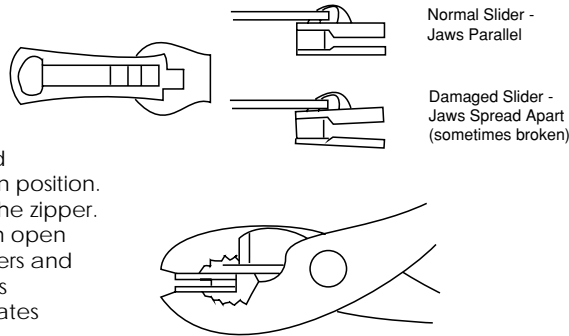

**Water:** Seeping through at the seams may be stopped by applying 3-M Scotchgard® on the inside of the seams. Rips in the fabric may be repaired with Bondex® iron on patches. Iron the patches to the inside of the top, carefully following the Bondex® instructions.

**Snaps:** Keep snaps cleaned and lubricated with silicone to help prevent snaps from sticking to the studs. If a snap does become stuck to a stud, use a screwdriver and GENTLY pry apart to prevent permanent damage to the snap or the top fabric.

