







Installation Instructions TrailMax™ II Fixed Rear Seat

Vehicle Application

- Jeep CJ5s, CJ7s and Wranglers
1955 – 1995
Part Number: 39437

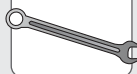
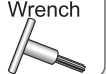
INSTALLATION TIME	SKILL LEVEL
 1/2 Hour	 1 - Easy

TOOLS			
 Wrench 13 mm and 5/8"	 Torx Wrench T-50	 Power Drill 25/64" Bit	 Safety Glasses





Installation Tips

Before you begin installing this assembly, read all instructions thoroughly.

For a smooth fit:

For ease in installation, the product should be installed at temperatures above 72° F. Below this temperature, the fabric may contract an inch or more, making it difficult to fit to the vehicle. It is normal for fabric to contract and wrinkle when stored in the shipping carton. Within a few days after the installation, the fabric will relax and the wrinkles will disappear.

 **CAUTION** Safety glasses should be worn at all times while installing this product.

 **WARNING** This product is designed primarily to enhance the appearance of the vehicle and to shield the occupants from ordinary weather conditions. Do not rely in any way on the components of this product to contain occupants within the vehicle, or to protect against injury or death in the event of an accident. This product will not protect the occupants from falling objects. Never operate the vehicle in excess of manufacturer's specifications.

WEAR SEAT BELTS AT ALL TIMES

Read and follow, precisely, all installation instructions provided when installing product. Failure to do so may result in a poor fit and could place occupants of the vehicle in a potentially dangerous situation.

TrailMax™ II Fixed Rear Seat – Installation Instructions

Parts List and Hardware Identification

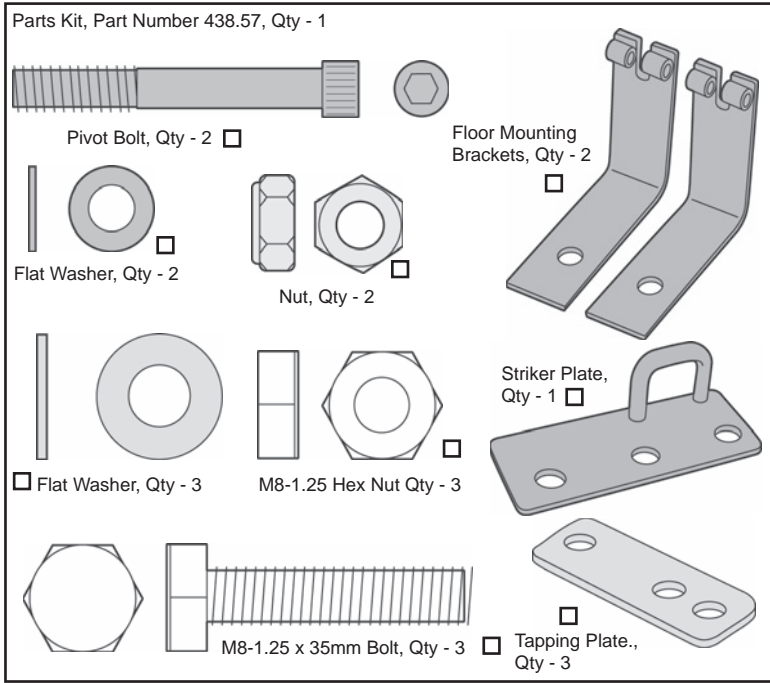
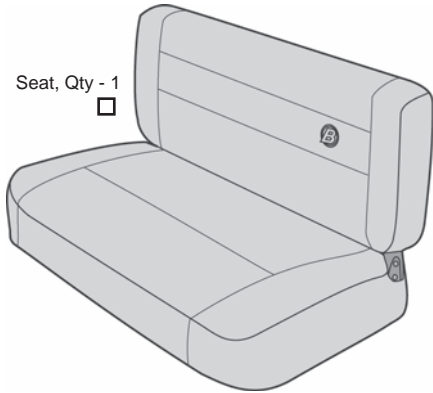

CAUTION

Before beginning the seat installation, set the parking brake, place the vehicle in gear or park and chock the wheels to reduce the risk of the vehicle unexpectedly moving, which could result in serious injury.

1

Remove the Existing Rear Seat

Remove the old rear seat. Remove the existing front mounting brackets. Discard the brackets, but set the bolts aside to be used to install the new seat.



WARNING

If your vehicle has carpet covering the floor, cut the carpet so that the Floor Mounting Brackets are installed flush on the metal floor. If the Floor Mounting Brackets are not flush mounted, the seatback may not lock in place, which could result in serious injury to you and others.

2

Floor Mounting Bracket Installation 1986 and Newer Vehicles

Locate the Floor Mounting Bracket mounting holes on the floor of the vehicle behind the front seat risers. Align the Floor Mounting Brackets over the mounting holes with the loops on each bracket positioned towards the front of the vehicle. Use the original bolts that were removed in Step 1 to install the Floor Mounting Brackets. Securely tighten the bolts.

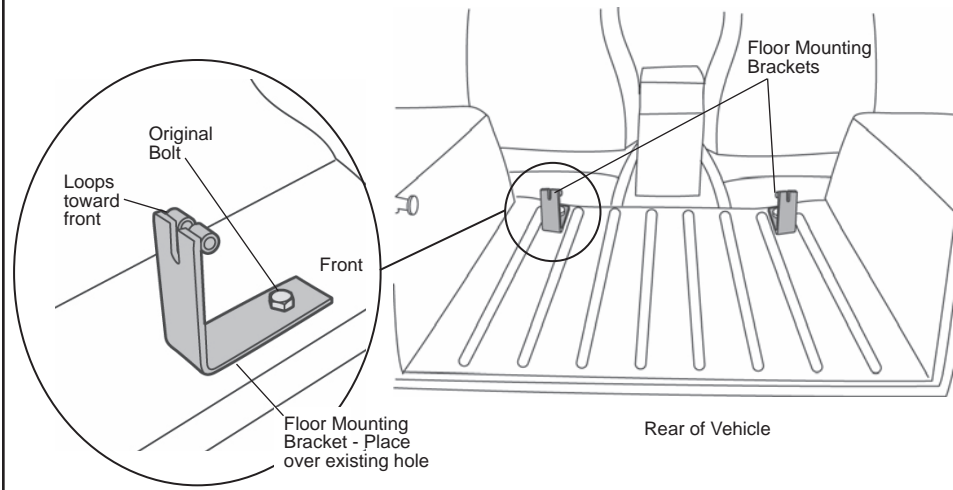

TrailMax™ II Fixed Rear Seat – Installation Instructions

3 Install Seat 1986 and Newer Vehicles

Orient the Seat, with the Legs on the bottom of the seat facing the rear of the vehicle. Place Seat in the vehicle.

Slide the Seat toward the front of the vehicle. Align the holes of the brackets, on the bottom of the seat cushion, with the Floor Mounting Bracket. Slide the Pivot Bolts through the holes in the Floor Mounting Brackets and through the brackets on the bottom of the seat. Slide a Washer over each Pivot Bolt and thread a Nut on the end of each Pivot Bolt.

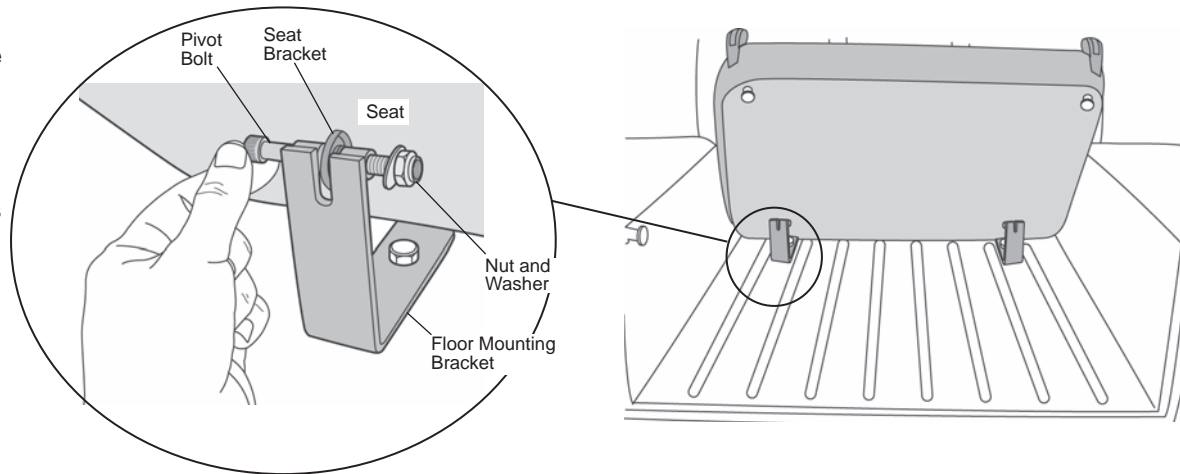

4 Install Striker Plate 1986 and Newer Vehicles

Remove the Seat Belt Mounting Bracket and set it aside to be reinstalled.

Orient the Striker Plate with the raised catch toward the rear of the vehicle. Place the plate in the vehicle with the middle hole over the hole from the seat belt bracket and the catch toward the rear. Re-place the Seat Belt Mounting Bracket on top of the Striker Plate and align the hole in the bracket with the middle hole in the plate. Re-install the bolt to secure the Seat Belt Mounting Bracket and the Striker Plate.

Hook the lock on the rear of the seat to the catch on the Striker Plate.

Check that the Seat is in the proper position and that the Latch catches securely to the Striker Plate. Securely tighten all hardware.

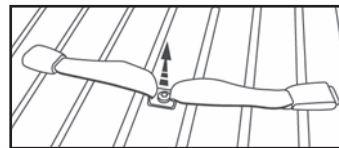

Remove Seat Belt Mounting Bracket

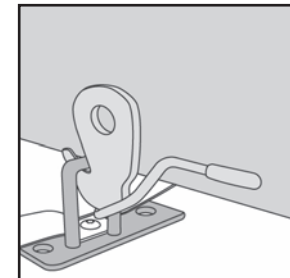
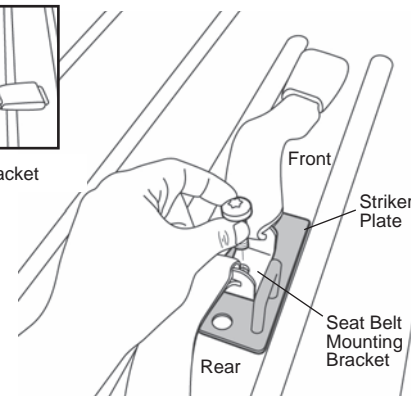

Hook Seat Latch to Striker Plate

TrailMax™ II Fixed Rear Seat – Installation Instructions



WARNING

If your vehicle has carpet covering the floor, cut the carpet so that the Floor Mounting Brackets are installed flush on the metal floor. If the Floor Mounting Brackets are not flush mounted, the seatback may not lock in place, which could result in serious injury to you and others.



WARNING

Check for wiring and fuel lines before drilling holes in floor.

NOTE

In 1985 and older vehicles, the seat installation will be easier with two people.

2 Floor Mounting Bracket Installation 1985 and Older Vehicles

Orient the Seat, with the Legs on the bottom of the seat facing the rear of the vehicle.

Orient the Floor Mounting Brackets with the loops toward the front of the vehicle. Attach the two (2) Floor Mounting Brackets to the bottom of the seat by sliding the Pivot Bolts through the holes in the Floor Mounting Brackets and through the brackets on the bottom of the seat. Slide a Washer over each Pivot Bolt and thread a Nut on the end of each Pivot Bolt.

Set the Seat in the rear of the vehicle and center it from side to side and in the desired position from front to rear.

Use the Floor Mounting Brackets as templates to mark the hole locations of the Floor Mounting Brackets. Remove the Pivot Bolts, Nuts and Washers and remove the Seat from the vehicle. Center punch and drill a 25/64" hole at each mark. Remove the Floor Mounting Brackets from the seat.

Align the Floor Mounting Brackets over the drilled holes with the loops on the brackets facing toward the front of the vehicle. From underneath the vehicle, align the Tapping Plates and M8-1.25 Hex Nuts over the drilled holes and hold them in place. Insert two (2) M8-1.25 x 35mm Bolts with two (2) Flat Washers through each Mounting Bracket and Tapping Plate into the Nut. Loosely tighten the bolts using an adjustable wrench or 13mm wrench.

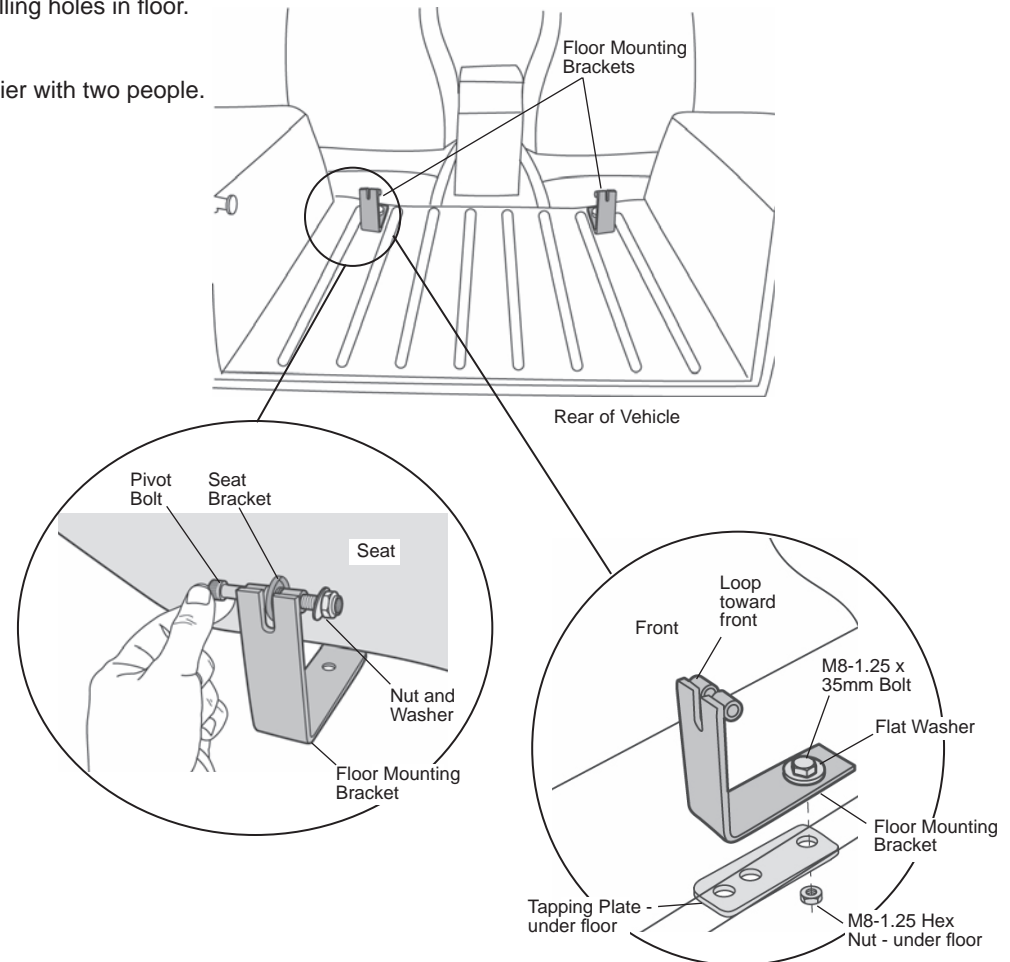

TrailMax™ II Fixed Rear Seat – Installation Instructions

3 Install Seat 1985 and Older Vehicles

Orient the Seat, with the Legs on the bottom of the seat facing the rear of the vehicle. Place Seat in the vehicle.

Slide the Seat toward the front of the vehicle. Align the holes of the brackets, on the bottom of the seat cushion, with the Floor Mounting Bracket. Slide the Pivot Bolts through the holes in the Floor Mounting Brackets and through the brackets on the bottom of the seat. Slide a Washer over each Pivot Bolt and thread a Nut on the end of each Pivot Bolt.

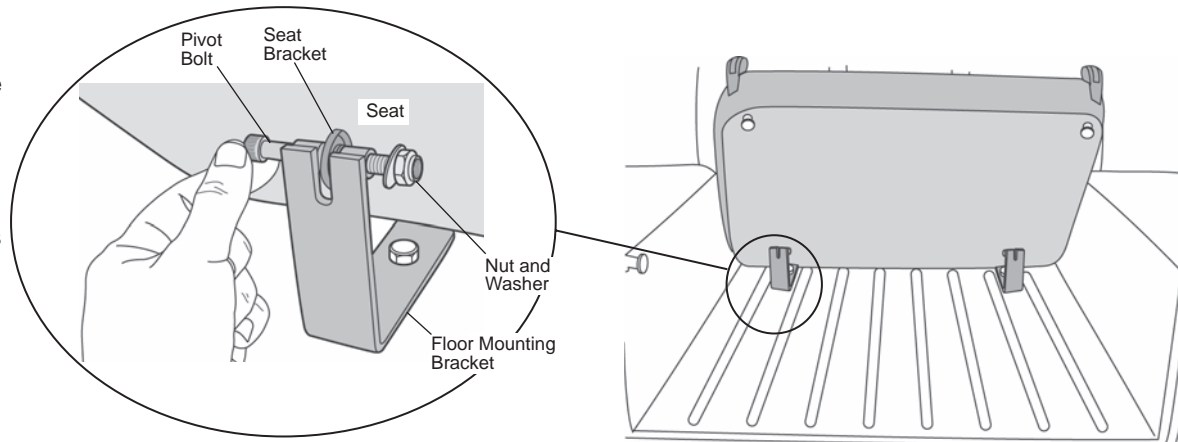

WARNING

Check for wiring and fuel lines before drilling holes in floor.



In 1985 and older vehicles, the seat installation will be easier with two people.

4 Install Striker Plate 1985 and Older Vehicles

Locate the Seat Latch in the center of the seat back, along the bottom.

Orient the Striker Plate with the raised catch toward the rear of the vehicle. Place it on the floor of the vehicle so that the Seat Latch hooks securely into the catch. Mark the locations of the middle hole in the Striker Plate. Center punch and drill a 25/64" hole at the mark.

Align the middle hole of the Striker Plate over the drilled hole with the catch toward the rear of the vehicle. From underneath the vehicle, align a Tapping Plate and M8-1.25 Hex Nut over the drilled hole and hold them in place. Insert an M8-1.25 x 35mm Bolt with a Flat Washer through the Striker Plate and Tapping Plate into the Nut. Loosely tighten the bolts using an adjustable wrench or 13mm wrench.

Check that the Seat is in the proper position and that the Latch catches securely to the Striker Plate. Securely tighten all hardware.

