



# Installation Instructions Duster

Vehicle Application:  
**Jeep® JL Wrangler Unlimited 2018-Current**  
Part Number 90036 (Requires #52700-01 with Optional #52603-01)

## Installation Tips

Before you begin installing your new Duster, please read all the instructions thoroughly.

**! WARNING** Do not rely in any way on the components of this product to protect against injury or death in the event of an accident. Never operate the vehicle in excess of manufacturer's specifications.

Read and follow, precisely, all installation instructions provided when installing this product. Failure to do so may result in a poor fit and could place occupants of the vehicle in a potentially dangerous situation.

## WEAR SEAT BELTS AT ALL TIMES

**! CAUTION** Safety glasses should be worn at all times when installing this product.

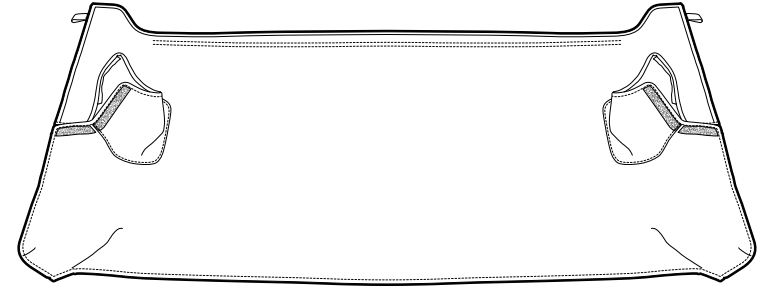

### Tools



Safety Glasses

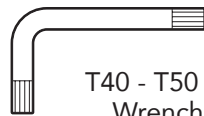

T40 - T50 Torx Wrenches (included in your Jeep tool kit)

### Installation Time



30 minutes

### Skill Level



1 - Easy



# Installation Instructions Duster

Vehicle Application:  
Jeep® JL Wrangler Unlimited 2018-Current  
Part Number 90036 (Requires #52700-01 with Optional #52603-01)

## Parts List

- Required parts for installation      - Page number in Installation Guide

### Sections 1 to 6      Duster, End Caps, Tailgate Bar & Retainers

Pages 4 to 9 of Guide

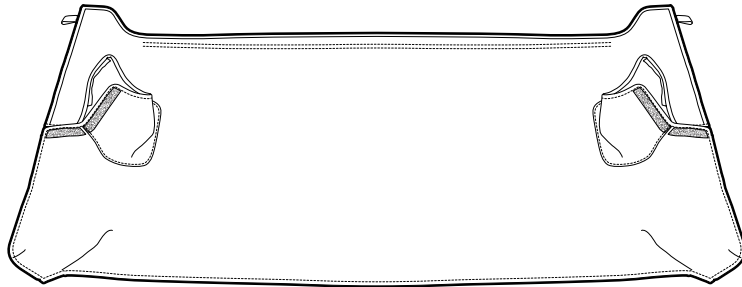

Duster  
Qty. 1

### Optional Parts, available separately in the Bestop #52603-01 Parts Kit.

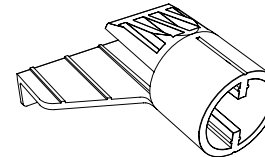

Plastic End Cap - Left  
Bestop Part #593.71  
Qty. 1

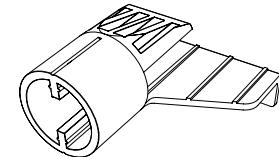

Plastic End Cap - Right  
Bestop Part #592.66  
Qty. 1

### Required Parts, available separately in the Bestop #52700-01 Parts Kit.

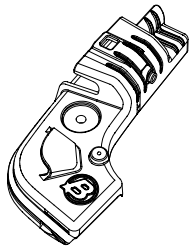

Tailgate Bar Retainer  
Part #575.38 - Right (shown)  
Part #575.39 - Left  
Qty. 1 of each

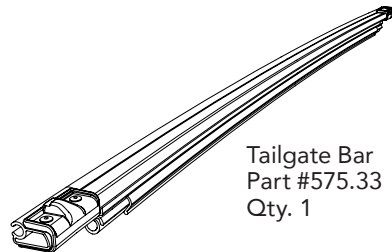

Tailgate Bar  
Part #575.33  
Qty. 1



M8 x 1.25 x 38  
Button Head  
Socket Cap Screw  
#532.17  
Qty. 2

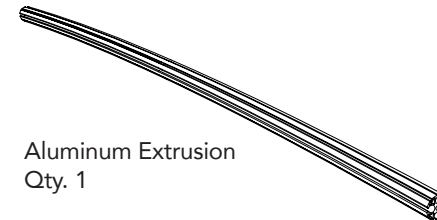

Aluminum Extrusion  
Qty. 1

**Step 1**

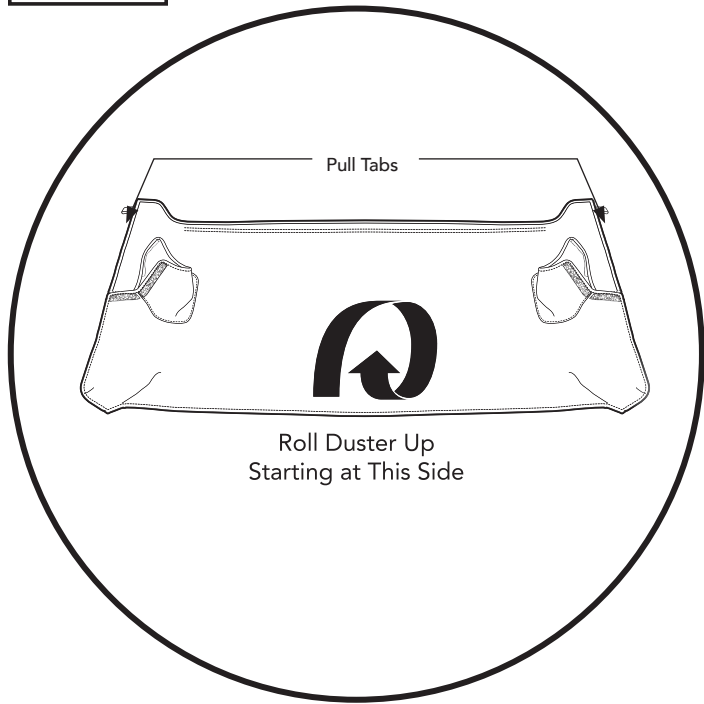

**Hardware**

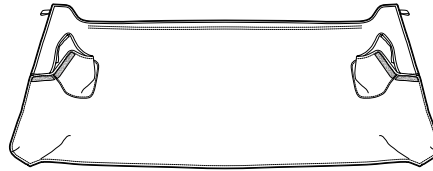

Duster  
Qty. 1

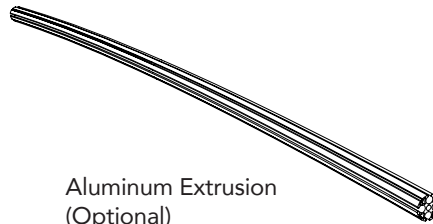

Aluminum Extrusion  
(Optional)  
Qty. 1  
Sold Separately in  
Bestop #52603-01 Kit

**Step 2**

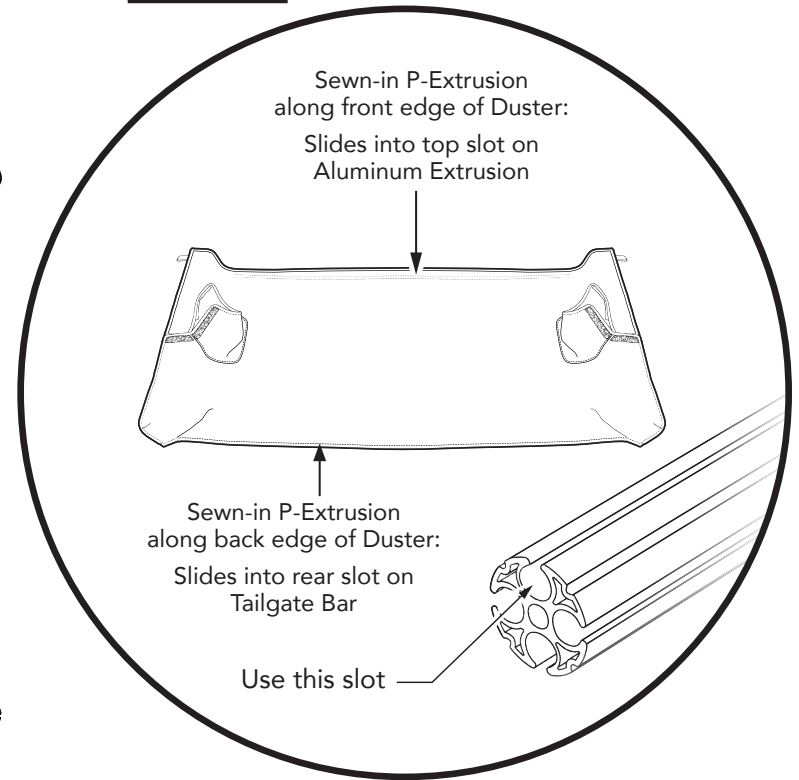

**Step 1**

Starting on the side of the duster without the pull tabs, roll the Duster up loosely.

The side of the Duster with the pull tabs is the front edge.

**Step 2**

With the Duster loosely rolled up, slide the P-Extrusion along the exposed front edge of the Duster into the top slot of the Extruded Aluminum Bow, using the slot in the Bow that is on top of the arch and facing up.

**Step 1** 593.71 592.66

**Hardware** 52603-01 Parts Kit

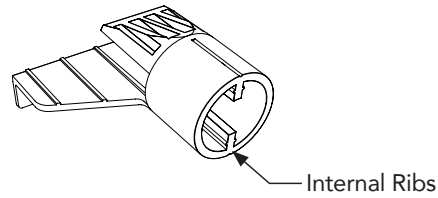
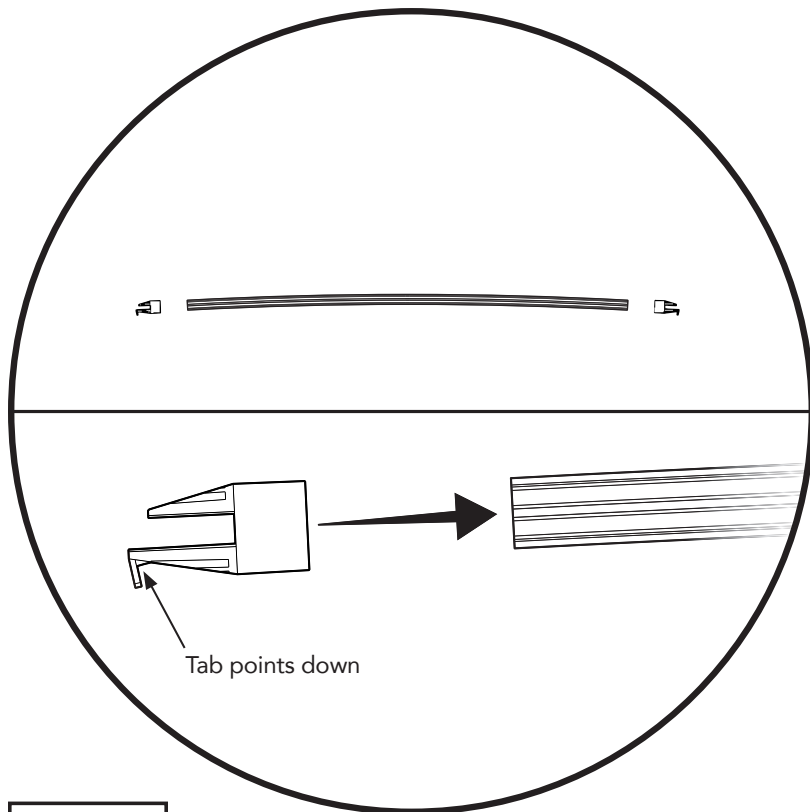

Plastic End Cap - Left  
(Optional)  
Bestop Part #593.71  
Qty. 1  
Sold Separately

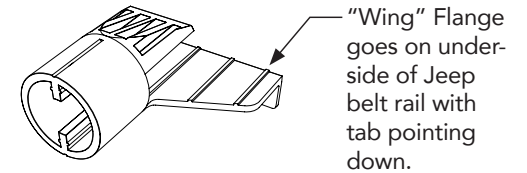

Plastic End Cap - Right  
(Optional)  
Bestop Part #592.66  
Qty. 1  
Sold Separately

**Step 1**

Place the Plastic End Caps #593.71 and #592.66 on the Extruded Aluminum Bow (Available separately with Bestop Parts Kit #52603-01).

The Caps should be aligned so that the "wing" flange is on the underside of the Jeep belt rail, and the tab on each flange is pointing down.

The internal ribs inside the round opening of each end cap will slide into the slots on the top and bottom of the aluminum extrusion.

## Step 1

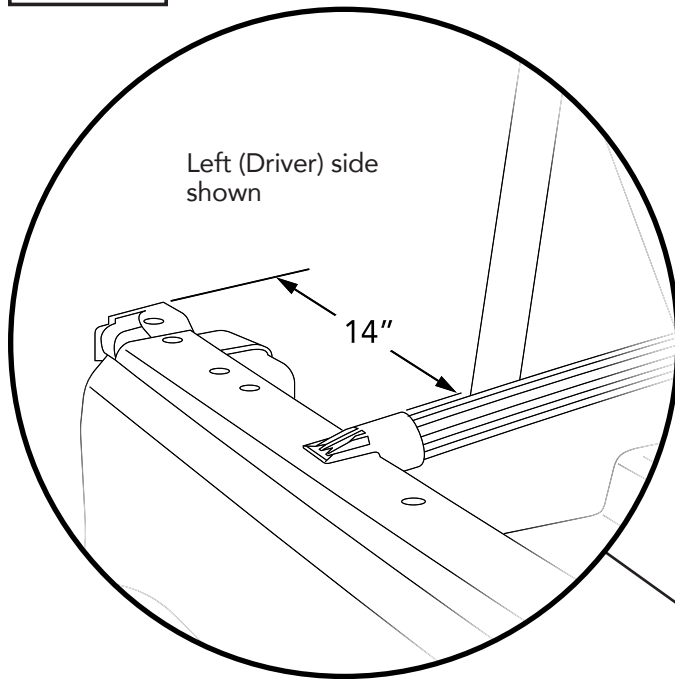

## Tools

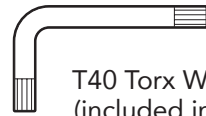

T40 Torx Wrench  
(included in your  
Jeep tool kit)

## Step 2

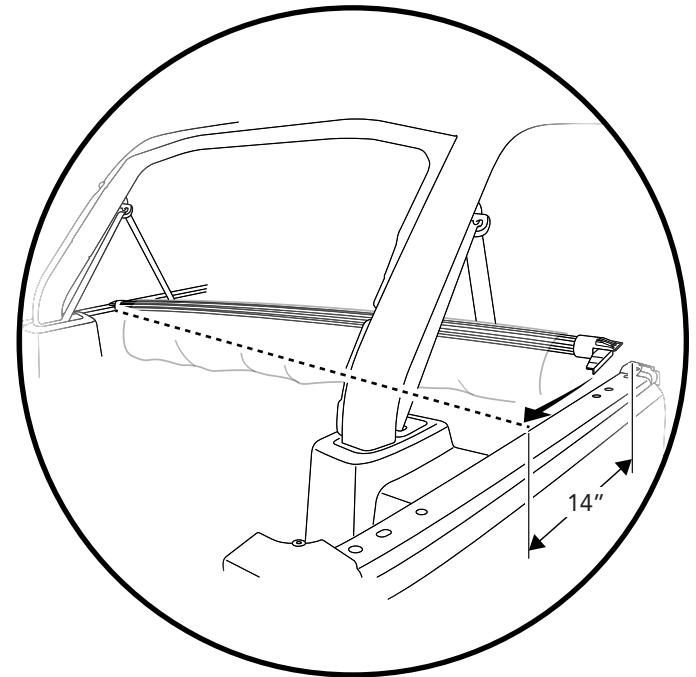

## Step 1

Slide the open end of one end cap with attached aluminum extrusion over the Jeep belt rail at a location 14.75" from the plastic trim cap at the rear of the door opening.

## Step 2

Now pivot the other end of the aluminum bow with attached end cap into place. Slide the opening of the end cap over the Jeep belt rail, and locate it the same distance - 14" - from the door opening trim cap on the same side.

**NOTE:** If you have Door Surrounds on your vehicle, you must remove some fasteners to allow the Door Surround to be moved out of the way before pivoting the Extrusion Bow into place. You do not need to remove the Door Surround - just move it out of the way. Use the T40 Torx Driver that comes in your Jeep's tool kit to remove the Door Surround fasteners.



<b>Step 1</b>	575.38	575.39	532.17
---------------	--------	--------	--------

<b>Hardware</b>	52700-01 Parts Kit
-----------------	--------------------

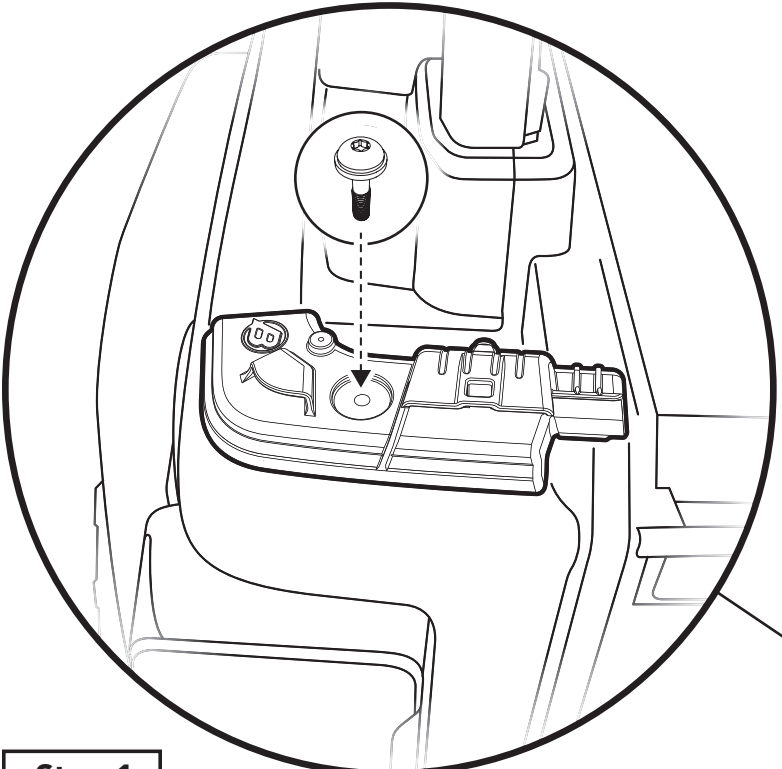

Tailgate Bar Retainer  
Part #575.38 - Right  
Qty. 1

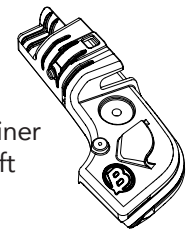

Tailgate Bar Retainer  
Part #575.39 - Left  
Qty. 1

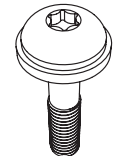

M8x1.25x38  
Button Head  
Socket Cap Screw  
#532.17  
Qty. 2

**Tools**

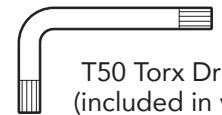

T50 Torx Driver  
(included in your  
Jeep tool kit)

**Step 1**

Attach the Tailgate Bar Retainers #575.38 (right) and #575.39 (left) to the Jeep Belt Rail, using one (1) M8x1.25x38 Button Head Socket Cap Screw #532.17 per retainer.

Insert the screws through the retainers, and into threaded holes in the top of the Jeep belt rail, and tighten.



## Step 1

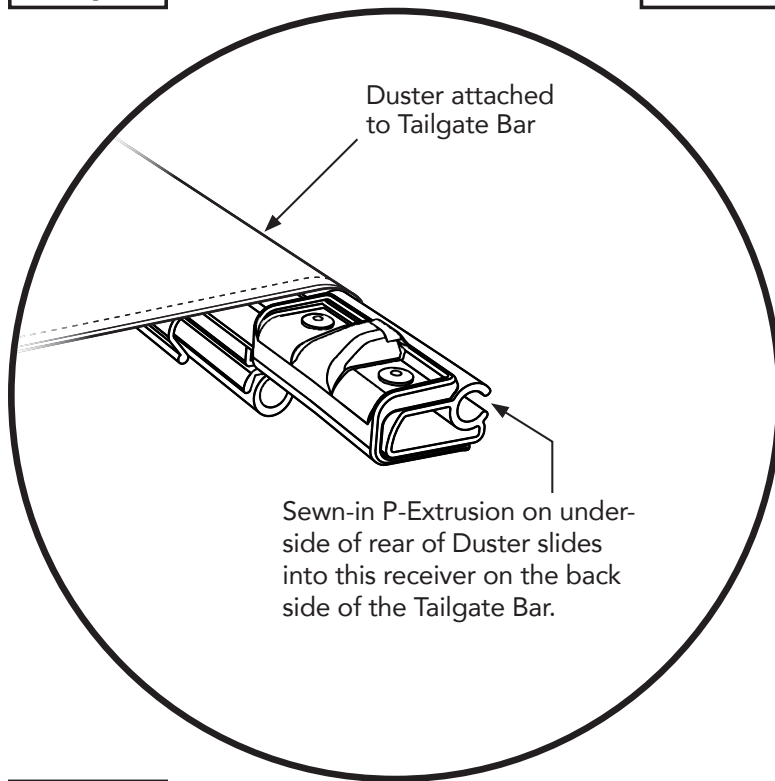

## Hardware

52700-01 Parts Kit

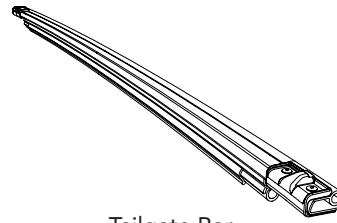

Tailgate Bar  
#575.33  
Qty. 1

## Step 2

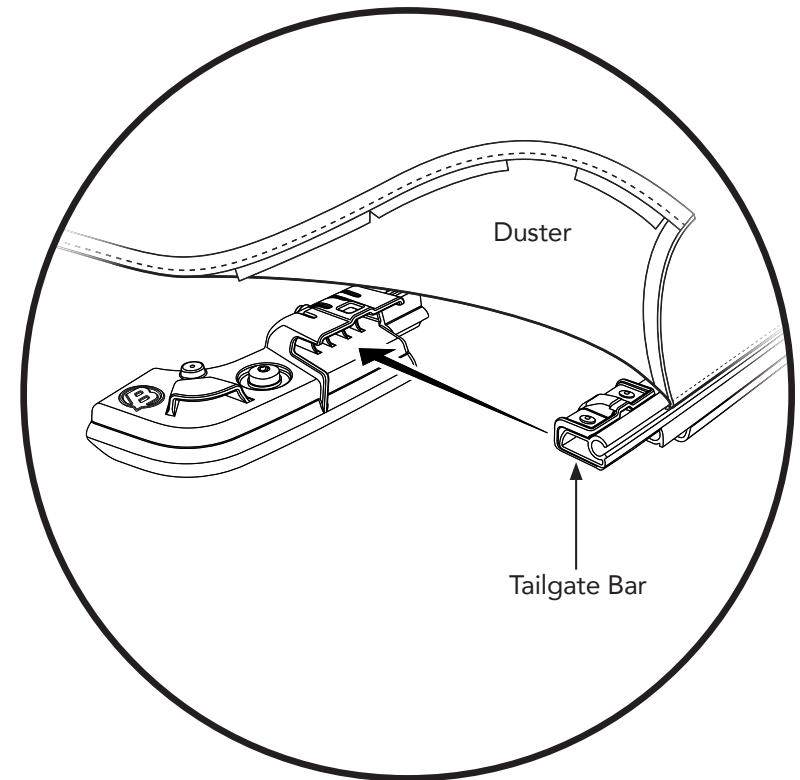

## Step 1

Attach the Tailgate Bar #575.33 (from #52700-01 Parts Kit) to the sewn-in P-Extrusion rail on the underside of the rear of the Duster.

Slide the Tailgate Bar all the way across.

## Step 2

Secure the Tailgate Bar with attached Duster to the Tailgate Bar Retainers that you installed in Section 4.

Press the Tailgate Bar into the receiver on each Tailgate Bar Retainer.

## Step 1

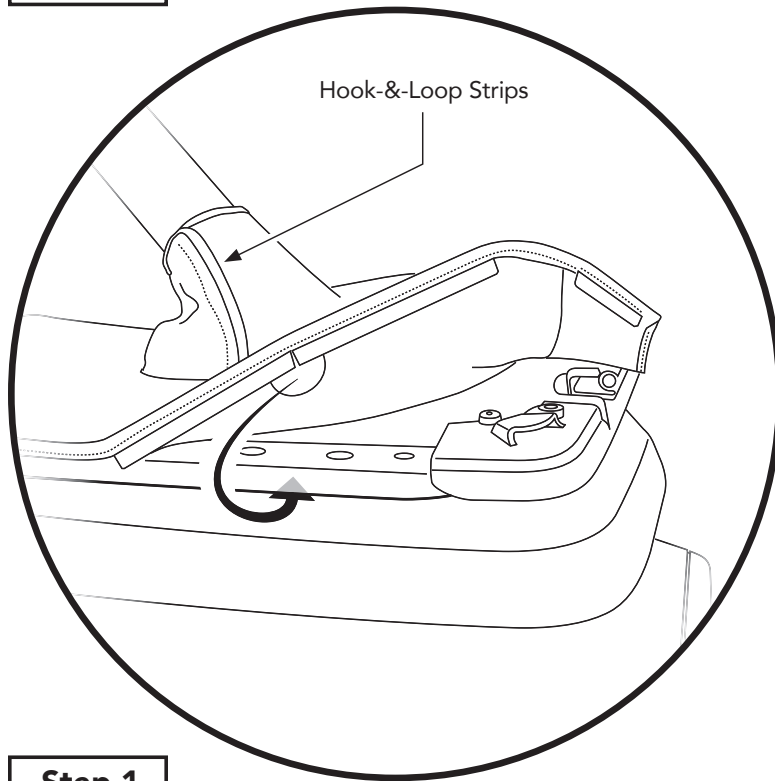

## Tools

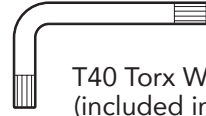

T40 Torx Wrench  
(included in your  
Jeep tool kit)

## Step 1

Tuck the plastic tabs along the left and right edges of the Duster underneath the Jeep belt rail, working from back to front.

Make sure to tuck the straight tabs as well as the semi-circular tabs under the belt rail.

Tuck all side plastic tabs under the belt rail, from back to front, and then tuck the plastic tabs at the rear corners under the belt rail.

Wrap the hook-&-loop sleeves around the sport bar downtubes, and attach hook-&-loop strips together snugly.

You may now return the Door Rail that you moved in Section 3 back into place and tighten the fasteners.