









Installation Instructions Cable Top OEX Replace-a-top™ with Tinted Windows

Upper Door Skins not included

Vehicle Application

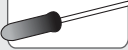
- Jeep Wrangler Unlimited (JK) 4 Door
2010 and newer
Part Number: 79349
Will fit 54723

INSTALLATION TIME	SKILL LEVEL
 <p>1 1/2 Hours</p>	 <p>2 - Moderately Easy</p>

TOOLS				
 <p>Phillips Screwdriver</p>	 <p>Masking Tape</p>	 <p>Pliers</p>	 <p>Torx Wrench</p> <p>T-15</p>	 <p>Safety Glasses</p>



<h3>Installation Tips</h3> <p>Before you begin installing this assembly, read all instructions thoroughly.</p> <p>For a smooth fit: For ease in installation, the product should be installed at temperatures above 72° F. Below this temperature, the fabric may contract an inch or more, making it difficult to fit to the vehicle. It is normal for fabric to contract and wrinkle when stored in the shipping carton. Within a few days after installation, the fabric will relax and the wrinkles will disappear.</p>

 <p>CAUTION Safety glasses should be worn at all times while installing this product.</p>

<p>WARNING This product is designed primarily to enhance the appearance of the vehicle and to shield the occupants from ordinary weather conditions. Do not rely in any way on the components of this product to contain occupants within the vehicle, or to protect against injury or death in the event of an accident. This product will not protect the occupants from falling objects. Never operate the vehicle in excess of manufacturer's specifications.</p> <p>WEAR SEAT BELTS AT ALL TIMES</p> <p>Read and follow, precisely, all installation instructions provided when installing product. Failure to do so may result in a poor fit and could place occupants of the vehicle in a potentially dangerous situation.</p>

Cable Top OEX Replace-a-top™ with Tinted Windows – Installation Instructions

Parts List

Fabric Top	Qty - 1
Quarter Window, Right	Qty - 1
Quarter Window, Left	Qty - 1
Rear Window	Qty - 1
Elastic Garter	Qty - 2

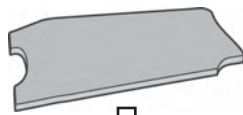

Header Foam, Driver's Side, Qty - 1

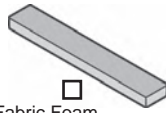

Fabric Foam, Qty - 2

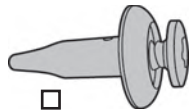

Unscrewing Rivet, Part Number 317.71, Qty - 4

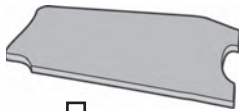

Header Foam, Passenger Side, Qty - 1

1 Remove Quarter Windows and Rear Window

Remove the Quarter Windows and the Rear Window. Remove the metal Tailgate Bar from the bottom of the Rear Window and set it aside.

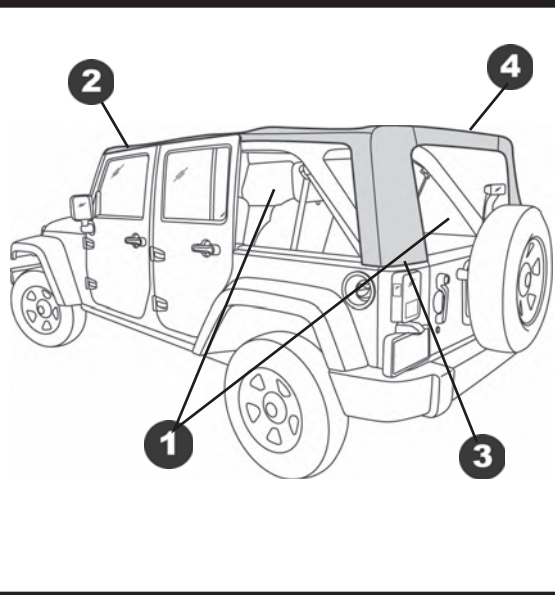

2 Release Windshield Latches

Release the latch that secures the header to the windshield. Pull up on the lever and then down and out to release the hook from the loop in the windshield frame.

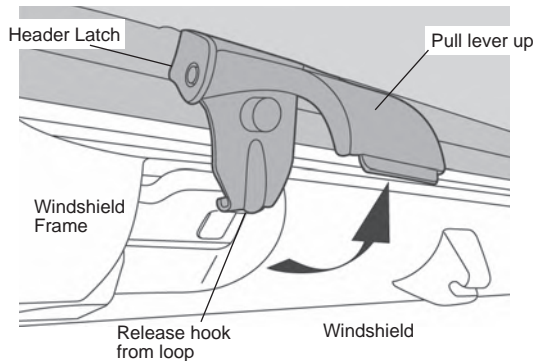

3 Release Rear Corners

Release the rear corners of the top. Pull gently down and then out to release the plastic strip from the retainer on the vehicle.

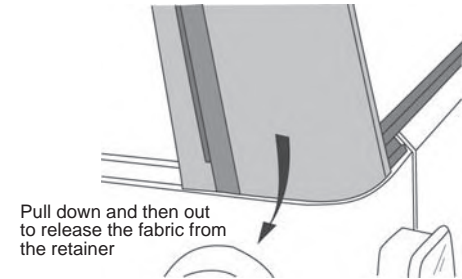

Pull down and then out to release the fabric from the retainer

4 Release Rear Bow

Use a phillips screwdriver to remove the four (4) screws that attach the flaps in the top to the Rear Bow. Set the screws aside to be reused later. Allow the bow to drop onto the tailgate.

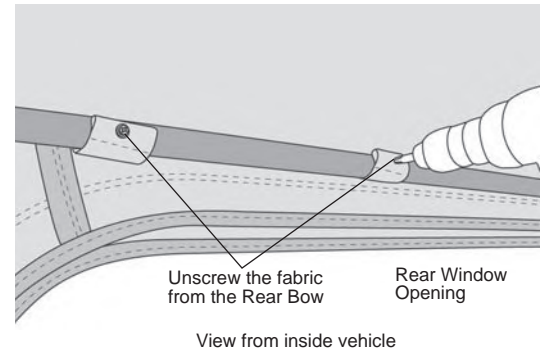

Cable Top OEX Replace-a-top™ with Tinted Windows – Installation Instructions

5 Release #3 Bow

Use a phillips screwdriver to remove the four (4) screws that attach the two (2) flaps in the top to the #3 Bow. Set the screws aside to be reused later.

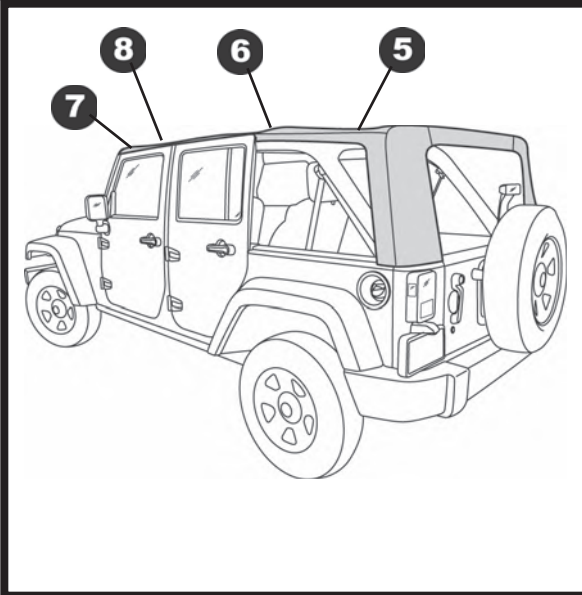
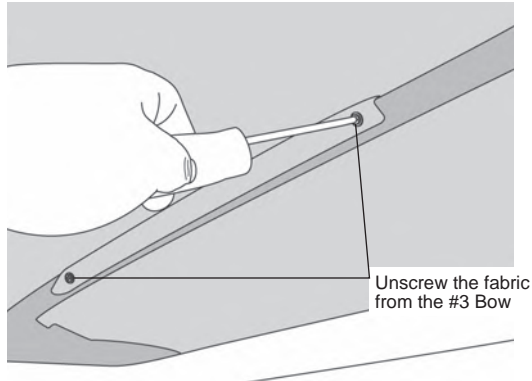

8 Remove Top Fabric

Raise the bow assembly and lock the header to the windshield.

Drape the top fabric, backing side up, over the hood and windshield. Remove the twenty-seven (27) screws that secure the fabric to the upper and lower headers. Set the screws aside for use in installing the new top. Slide the extrusion along the front edge of the top out of the channel in the lower header and remove the old top from the vehicle.

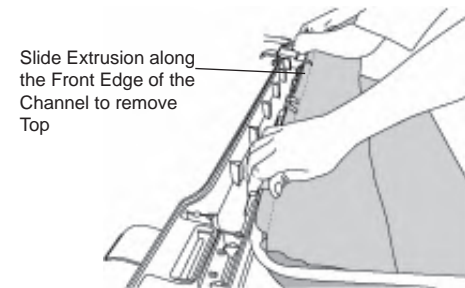
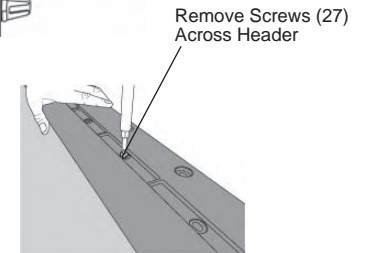
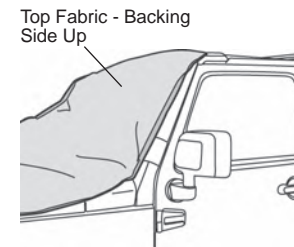

6 Release #2 Bow

Use a phillips screwdriver to remove the five (5) screws that attach the flap in the top to the #2 Bow. Set the screws aside to be reused later.

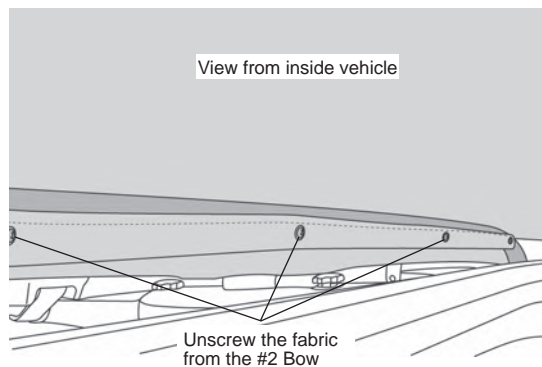

7 Remove Header Screws

Collapse the bow assembly down onto the tailgate to access the header. Use a T-15 Torx to remove the two screws that secure the fabric to the header.

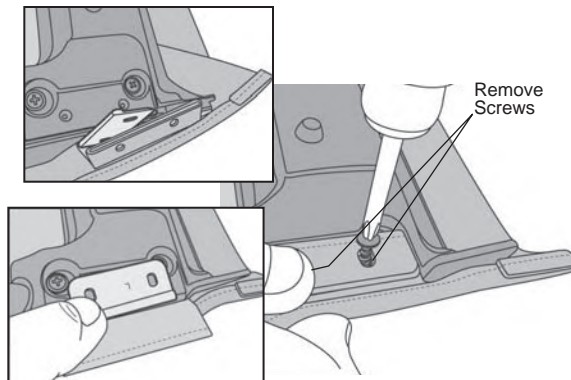

Cable Top OEX Replace-a-top™ with Tinted Windows – Installation Instructions

9 Install Top Fabric

Raise the bow assembly and lock the header to the windshield.

Drape the top fabric, backing side up, over the hood and windshield. Slide the extrusion along the front edge of the top into the channel in the lower header. Line up the center drill hole in the fabric with the center notch in the header. Use masking tape to help hold the fabric in place along the lower header.

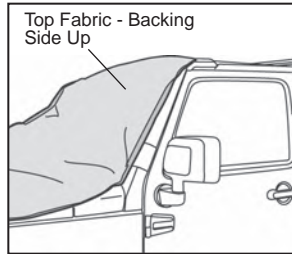

Slide Extrusion along the Front Edge of the Channel

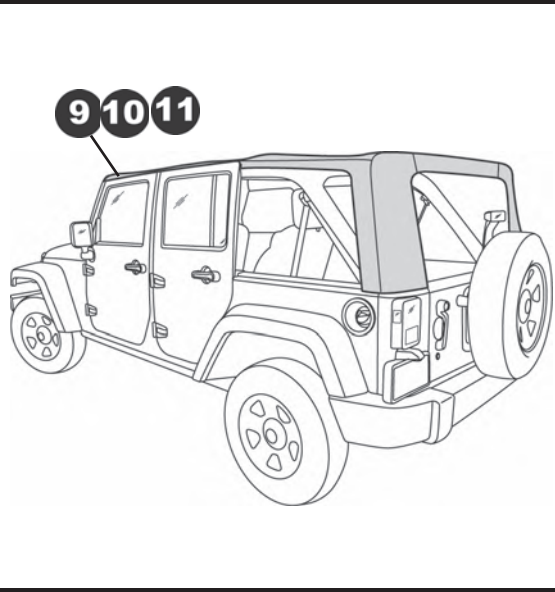
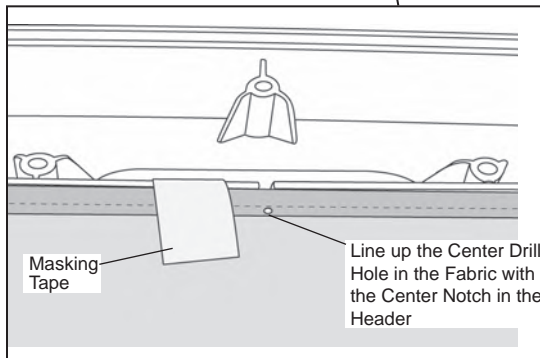
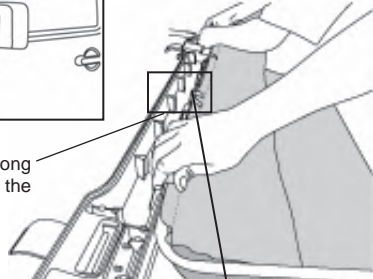

10 Install Top Fabric

Close the upper header over the fabric, sandwiching the fabric. Reinstall the four (4) corner screws. Then install the twenty-seven (27) screws across the header.

Lower the bow assembly to the rear of the vehicle.

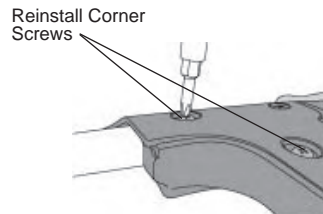

11 Install Corner Screws

Slip the fabric pocket sewn into the top between the headers and position the cable anchor.

Install two (2) T-15 Torx Screws through the fabric and metal flag into the Lower Header on each side.

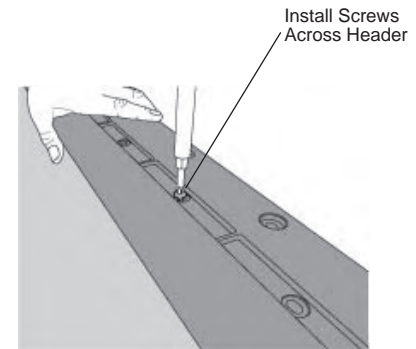
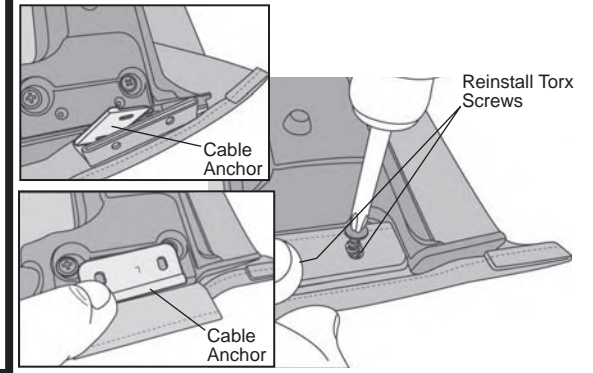

Cable Top OEX Replace-a-top™ with Tinted Windows – Installation Instructions

12 Install Fabric Foam

Peel the backing off the Fabric Foam and install it on each side of the Header.

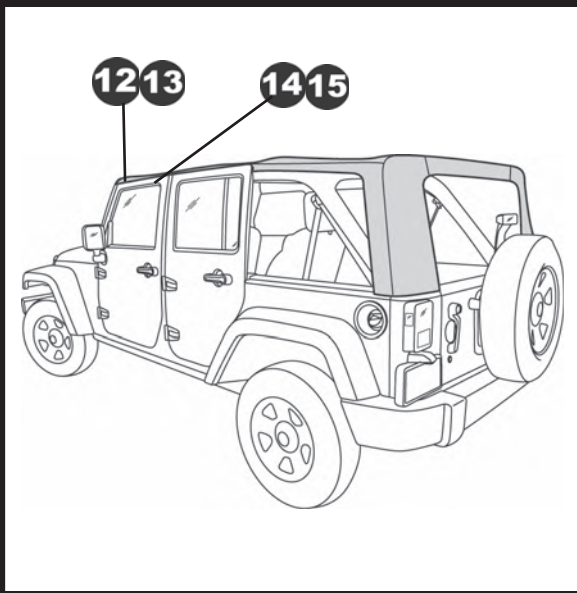
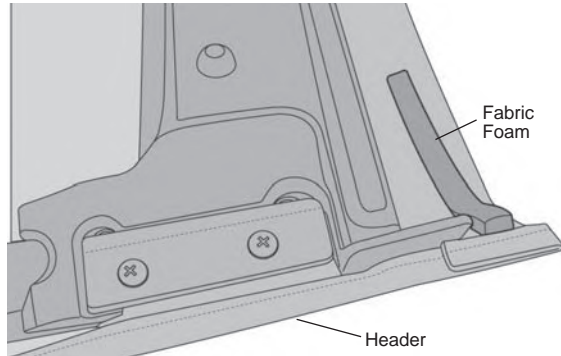

15 Secure Bow Assembly

Slide the Pivot Assembly on the Top along the track above the door until it latches into place.

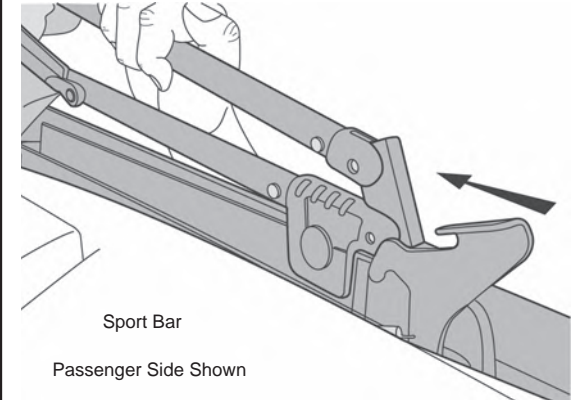

13 Install Header Foam

Peel the backing off the Driver's Side Header Foam and install it on the driver's side of the Header. Repeat on the passenger side.

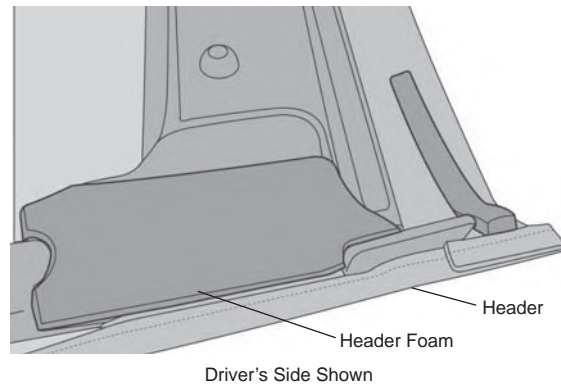

14 Install Bow Assembly

Open the Top Assembly and drape it over the cab of the vehicle.

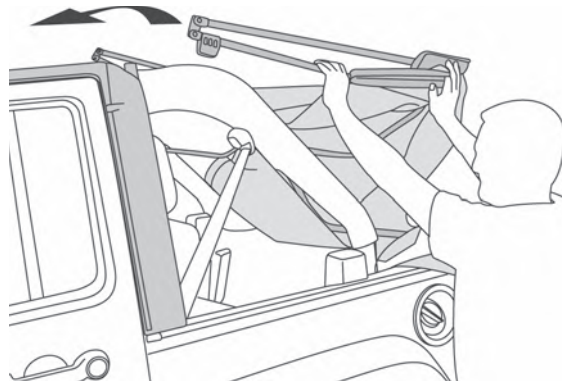

16 Pull Fabric Over Bows

Pull the fabric up over the bow assembly.



Cable Top OEX Replace-a-top™ with Tinted Windows – Installation Instructions

17 Secure Cable Spring

Hook the Cable Spring to the bracket on the bow and use pliers to crimp the spring.

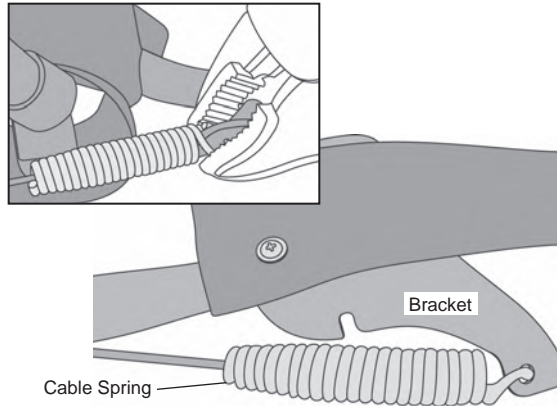

18 Secure Header to Windshield

Close the header latches to secure the front of the top to the windshield. Catch the hook in the loop in the windshield frame and then close the lever over it so that it lays flat against the windshield frame.

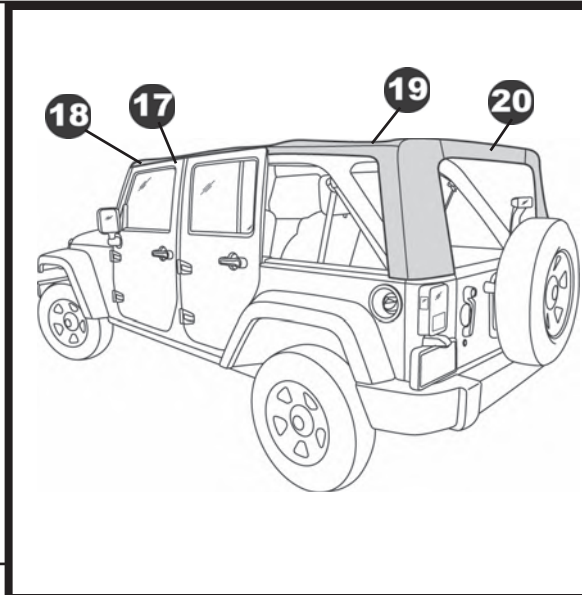
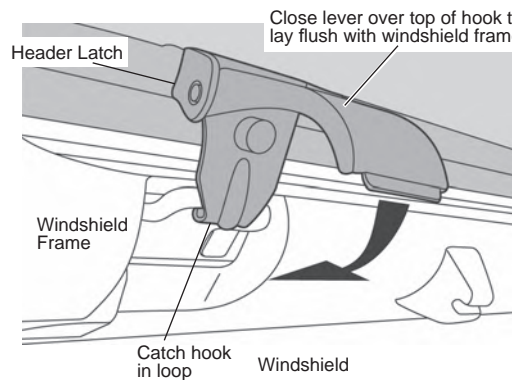

2010 – 2012 Only

19 Secure #3 Bow

Reinstall the four (4) screws that attach the two (2) flaps in the top to the #3 Bow.

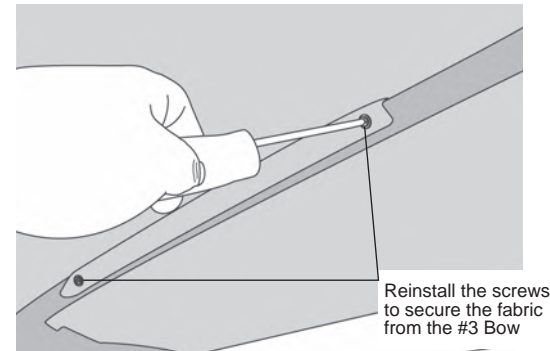

20 Attach Top to Rear Bow

Locate the flaps inside the top above the rear window opening. Use the four (4) screws that were removed in Step 4 to secure the flaps to the Rear Bow.

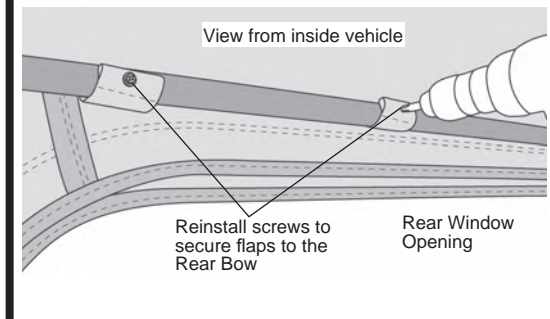

2013 + Only

19 Secure #3 Bow

Use four (4) Unscrewing Rivets to attach the two (2) flaps in the top to the #3 Bow. If necessary open the holes in the fabric for the new fasteners by first pushing the screws removed in Step 5 through the fabric flap. Remove them and then use a screwdriver to carefully open the holes to fit the Rivet. Install the Rivet through the fabric into the Bow.

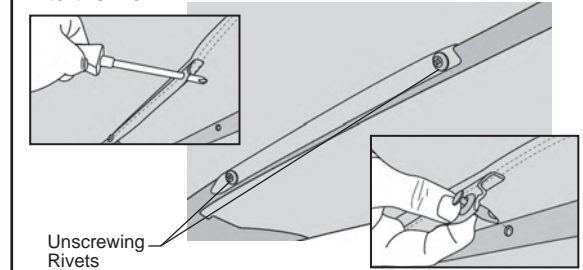

Cable Top OEX Replace-a-top™ with Tinted Windows – Installation Instructions

21 Secure #2 Bow

Reinstall the screws removed in Step 6 to secure the fabric to the #2 Bow.

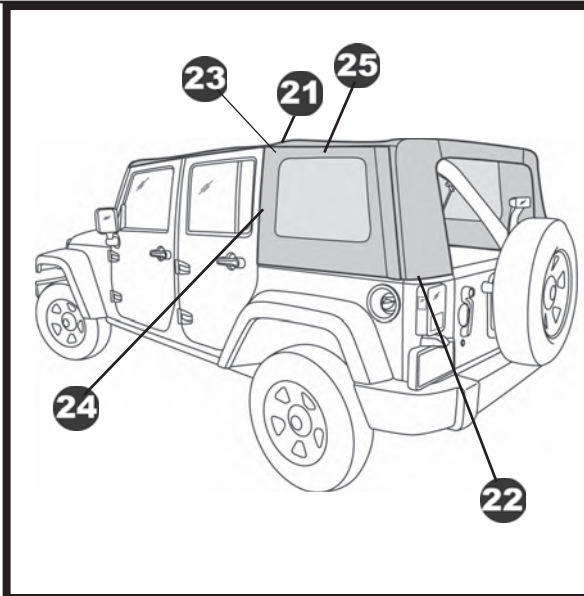
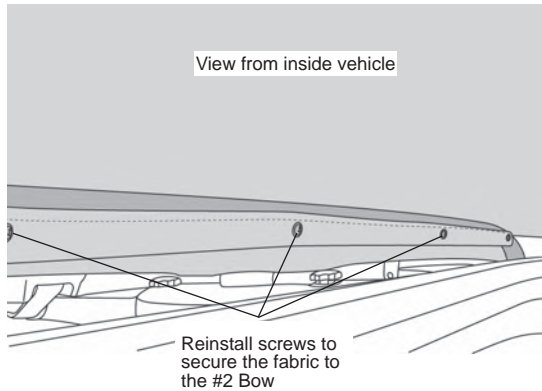

24 Secure Front of Quarter Window

Roll the plastic strip along the front of the Quarter Window into the channel in the Door Surround.

Roll Plastic Strip into channel in retainer

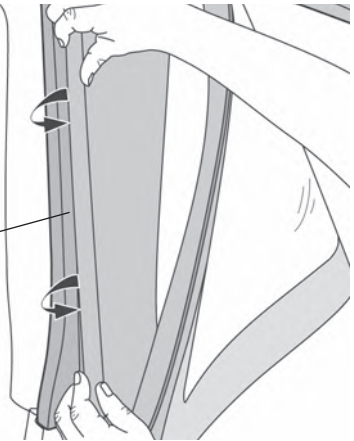

22 Secure Rear Corners

Pull down gently on the Rear Bow and work the plastic sewn to the rear corners of the top into the retainer on the vehicle.

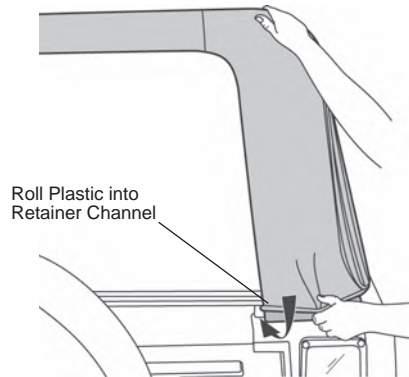

23 Attach Quarter Window Zippers

Start the zipper on the Quarter Window and close it 1-2 inches.

Start Zipper on Quarter Window

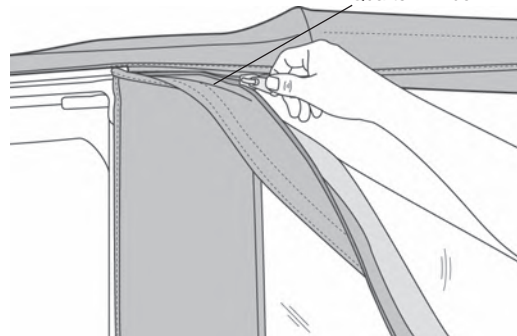

25 Secure Quarter Window

Close the zipper and slip the plastic along the bottom of the Side Window into the channel on the vehicle.

Fasten the hook and loop strip above the window to the top.

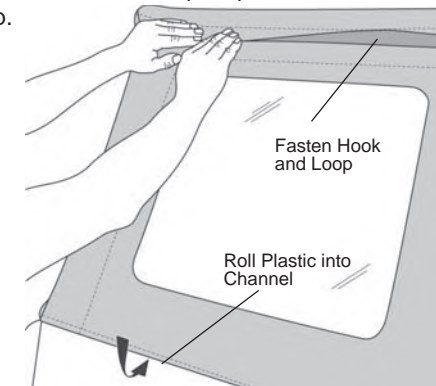

Cable Top OEX Replace-a-top™ with Tinted Windows – Installation Instructions

26 Install Elastic Garters

Snap the Elastic Garters to the snaps on the Rear Bow above the rear window opening.

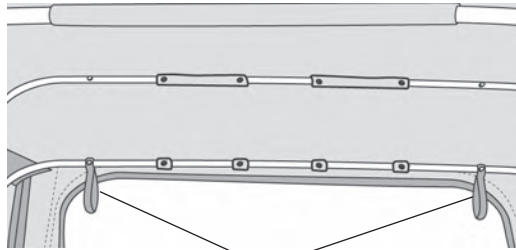

Snap Elastic Garters to Rear Bow

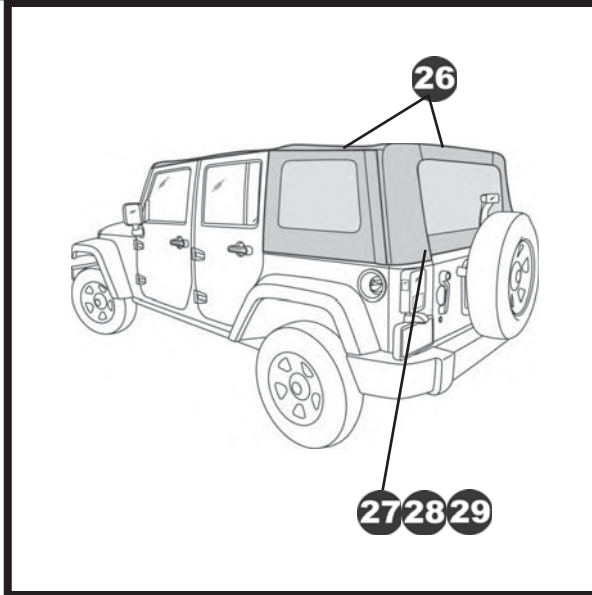

29 Secure Rear Window Zippers

To start the zipper, pull the two sliders as far down as possible on the driver's side of the window in order to catch the sliders to the pin.

Once the zipper is caught, start the top slider 1/2". Then hold up the top of the window with one hand and close the zipper with the other. The zipper is sandwiched between layers of fabric in the corners so be careful not to catch extra fabric in the zipper. Close the zipper.

Make sure that the Tailgate Bar is centered and is securely in the mounts. Then tuck the flaps on the Rear Window under the top fabric.

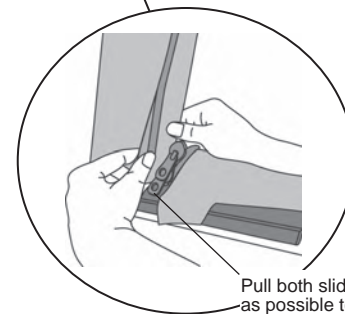
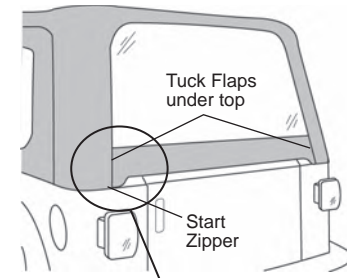

27 Install Tailgate Bar on Vehicle

Insert the Tailgate Bar into the mounts on each side of the tailgate opening with the vinyl side of the Rear Window toward the outside of the vehicle.

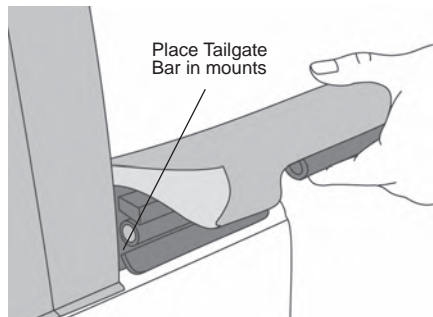

28 Install Tailgate Bar on Rear Window

Remove the Rear Window from the box and lay it flat with the backing side up. Locate the Tailgate Bar set aside in Step One. The bar has a "C" shaped channel, when viewed from the end. Orient the bar with the round seal down and slide the "C" channel on the retainer onto the tubed strip sewn to the backing side of the Rear Window.

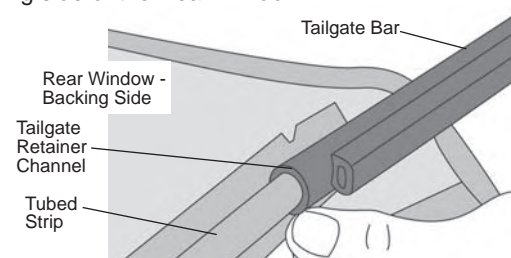

Cable Top OEX Replace-a-top™ with Tinted Windows – Installation Instructions



WARNING

When operating the vehicle without the Quarter Windows, the Rear Window should be rolled up and secured with the elastic garters for proper ventilation.

30 To Fold the Top Down Remove Quarter Panels and Rear Window

Remove the Quarter Panels and the Rear Window. To remove the Quarter Windows, unzip the rear and top zippers. Release the plastic strip from the retainer. Release the Hook and Loop Fasteners from around the Vertical Retainer. To roll up the Rear Window, remove the Tailgate Bar and open the zippers on each side of the window to the top. Start at the bottom and roll the window to the inside. Avoid wrinkles in the fabric and window. Secure it in place with the elastic garters inside of the top.

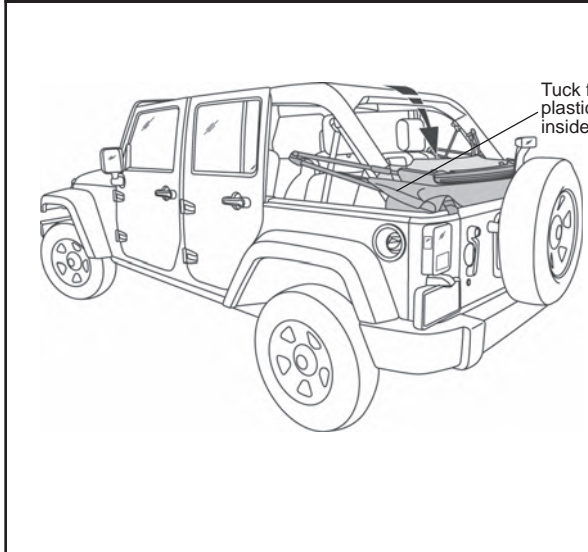
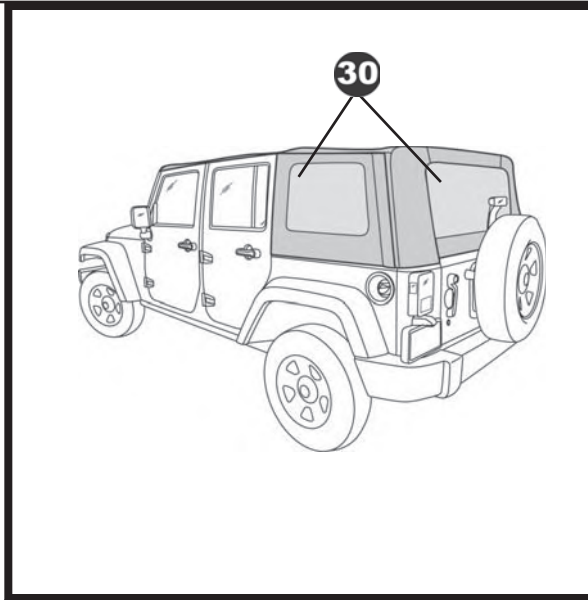

31 To Fold the Top Down Collapse Top

Release the front of the top from the windshield. Raise the front of the deck and collapse the rear bows, tucking the two plastic strips above the door openings and the stay pad on the rear bow inside of the bows. Wrap the fabric around the bows, then tuck the rear legs of the top under the bows.

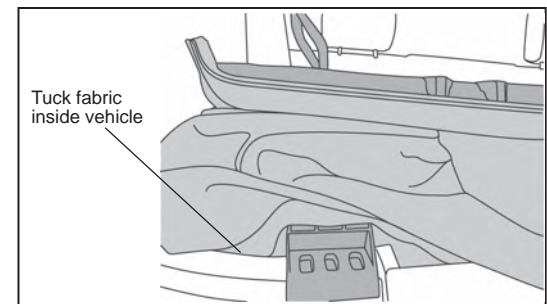
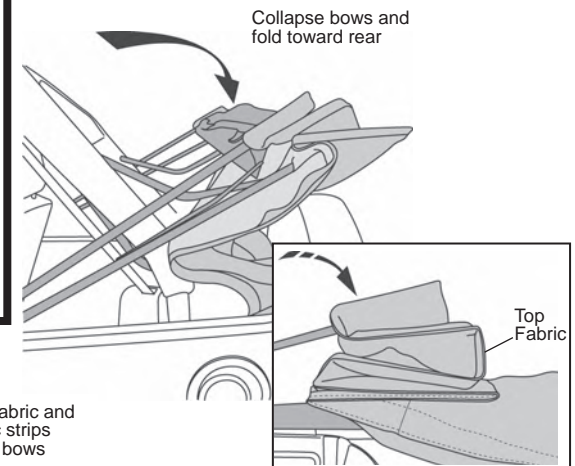

Cable Top Sailcloth Replace-a-top™ with Tinted Windows – Installation Instructions

Care and Maintenance of your Bestop Product

Your Bestop product is made of the finest materials available. To keep it looking new and for the maximum possible wear, it will need periodic cleaning and maintenance.

Fabric: The fabric should be washed often using soap, warm water and a soft bristle brush. Rinse with clear water to remove all traces of soap. Bestop recommends using Bestop Cleaner (part no. 11201-00) and Bestop Protectant (part no. 11202-00). Bestop Cleaner and Bestop protectant are specially formulated to provide a total cleaning and protection system. Bestop Cleaner safely removes the toughest stains, will not harm vehicle finishes, is biodegradable and environmentally friendly. Bestop Protectant protects against UV-fading, cracking and hardening, and repels dust, grease, dirt and mildew.

Windows: Keep windows clean to avoid scratching. DO NOT use a brush on the windows! Wash with a water-soaked cloth or sponge and a mild dishwashing detergent. Bestop recommends Bestop Vinyl Window Cleaner (part no. 11203-00), which safely cleans and protects vinyl windows and helps prevent UV damage. NEVER WIPE THE WINDOWS WHEN THEY ARE DRY. Be careful when cleaning snow or frost from the vinyl windows since they are easily scratched and may crack at low temperatures. DO NOT roll the sides or rear window in cold weather. The windows become stiff and will crack. Cracks caused by misuse in cold temperatures are not covered under warranty.

Zippers: Keeping zippers cleaned and lubricated with Bestop's Zipper Cleaner (part no. 11206-00) will help prevent damage and keep the zippers in smooth working condition. If a zipper opens behind the slider, the slider may have been spread apart. This problem can usually be repaired by using an ordinary pair of pliers to bring the sides back into parallel. Return slider to the end of the zipper in the normal Open position. Squeeze lightly at first and test the zipper. If the zipper continues to remain open squeeze more firmly with the pliers and try the zipper again. Repeat this procedure until the zipper operates correctly.

Water: Seeping through at the seams may be stopped by applying 3-M Scotchgard® on the inside of the seams. Rips in the fabric may be repaired with Bondex® iron on patches. Iron the patches to the Inside of the top, carefully following the Bondex® instructions.

Snaps: Keep snaps cleaned and lubricated with silicone to help prevent snaps from sticking to the studs. If a snap does become stuck to a stud, use a screwdriver and GENTLY pry apart to prevent permanent damage to the snap or the top fabric.

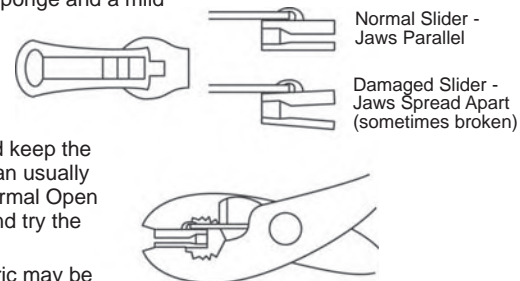

Learn more about soft tops and hard tops on our website.