



Installation Instructions Supertop for Trucks

Vehicle Application:
Ford F-150 2015-Current 6.5' Bed
Part Number 77336

Installation Tips

Before you begin installing your new Supertop for Trucks, please read all the instructions thoroughly.

It is recommended that two people install this Bestop product.

For a smooth fit:

For easier installation, the top should be installed at a temperature above 72° F. Below this temperature, the fabric may contract an inch or more, making it difficult to fit the vehicle. You may let the fabric sit in the sun for 15-20 minutes before installing to let the fabric warm up.

It is normal for the fabric to contract and wrinkle when stored in the shipping carton. Within a few days after installation, the fabric will relax and the wrinkles will disappear.









WARNING Do not rely in any way on the components of this product to protect against injury or death in the event of an accident. Never operate the vehicle in excess of manufacturer's specifications.

Read and follow, precisely, all installation instructions provided when installing this product. Failure to do so may result in a poor fit and could place occupants of the vehicle in a potentially dangerous situation.

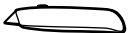
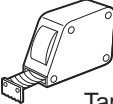

CAUTION Safety glasses should be worn at all times when installing this product.

WEAR SEAT BELTS AT ALL TIMES

Tools			
 Ratchet	 9/16" Socket	- OR -	 9/16" Wrench
 Safety Glasses	 1/8" Allen Wrench	 Utility Knife	 Tape Measure
 Pliers	 Phillips Screwdriver	 T20 Torx Driver Qty. 1	 Torque Wrench

Installation Time
 2 hours

Skill Level
<div style="display: flex; justify-content: space-around; align-items: center;"> <div style="border: 1px solid black; border-radius: 50%; width: 30px; height: 30px; display: flex; align-items: center; justify-content: center;">1</div> <div style="border: 1px solid black; border-radius: 50%; width: 30px; height: 30px; display: flex; align-items: center; justify-content: center;">2</div> <div style="border: 2px solid black; border-radius: 50%; width: 30px; height: 30px; display: flex; align-items: center; justify-content: center;">3</div> <div style="border: 1px solid black; border-radius: 50%; width: 30px; height: 30px; display: flex; align-items: center; justify-content: center;">4</div> </div> <p>3 - Moderately Difficult</p>





Installation Instructions Supertop for Trucks

Vehicle Application:
Ford F-150 2015-Current 6.5' Bed
Part Number 77336

Parts List

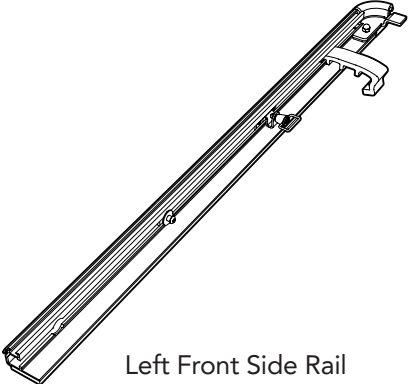
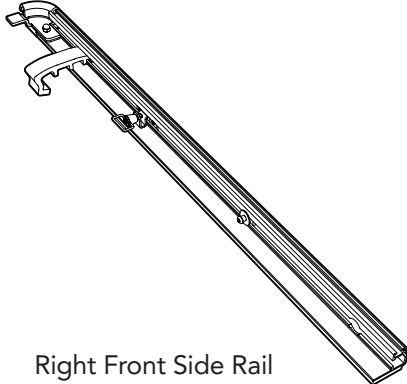
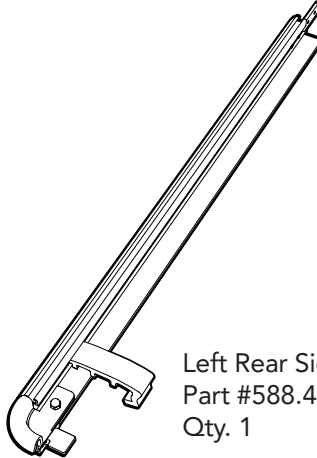
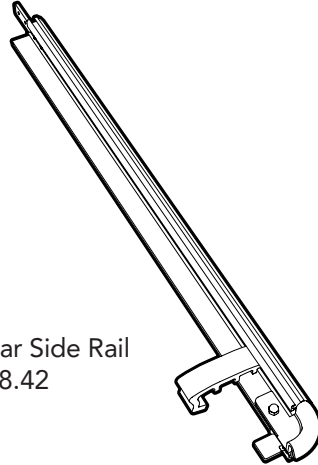
- Required parts for installation

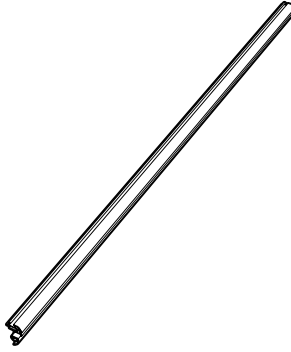
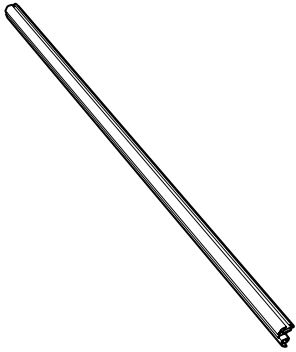
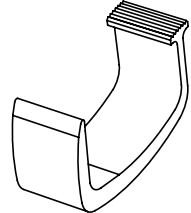
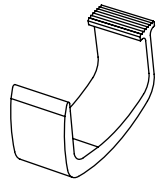
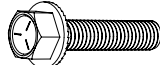
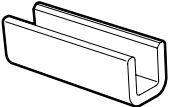
Sections 1 & 2		Side Rails	
			
Left Front Side Rail Part #594.29 Qty. 1	Right Front Side Rail Part #594.30 Qty. 1	Left Rear Side Rail Part #588.41 Qty. 1	Right Rear Side Rail Part #588.42 Qty. 1

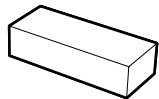
Sections 2 to 4				Hardware, Front and Rear Rails		Pages 6 to 9 of Guide	
							
Front Rail Part #584.94 Qty. 1	Rear Rail Part #584.95 Qty. 1	Lower Clamp - Large Part #579.23 Qty. 2	Lower Clamp - Small Part #595.34 Qty. 2	Hex Head Bolt Part #578.39 Qty. 4	Clamp Pad Part #577.39 Qty. 2	Set Screw Part #573.17 Qty. 4	Rubber Pad Part #720035 Qty. 4







Installation Instructions Supertop for Trucks

Vehicle Application:
Ford F-150 2015-Current 6.5' Bed
Part Number 77336

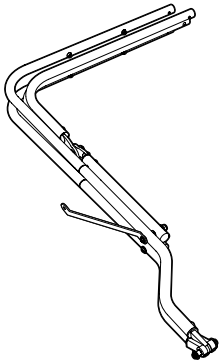
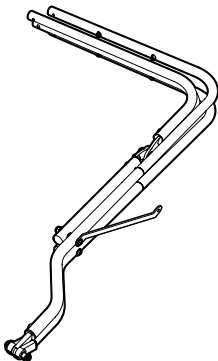
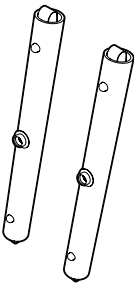
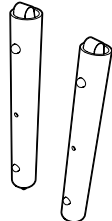
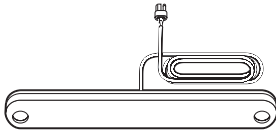
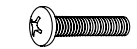
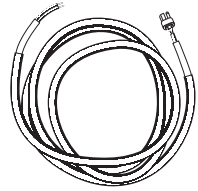
Parts List

- Required parts for installation

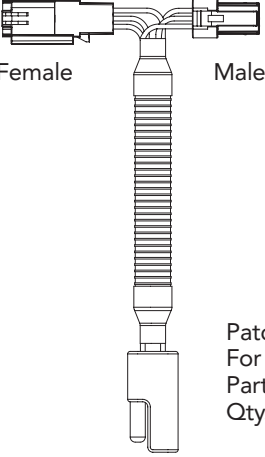
Sections 5 to 22		Bow Stacks, Bow Couplers, Wire Connectors; CHMSL Kit			
 <p>Bow Stack - Driver Side Part #579.39 Qty.1</p>	 <p>Bow Stack - Passenger Side Part #579.38 Qty.1</p>	 <p>Bow Coupler #1 & #4 Bows Part #573.77 Qty. 2</p>	 <p>Bow Coupler #2 & #3 Bows Part #573.79 Qty. 2</p>	<div data-bbox="1318 386 1600 435" style="border: 1px solid black; padding: 2px; display: inline-block;">Parts Kit #576.71</div> <div data-bbox="1348 457 1621 587">  <p>Center High-Mount Stop Light (CHMSL) Qty. 1</p> </div> <div data-bbox="1381 734 1516 782">  <p>#10-32 Screw Qty. 2</p> </div> <div data-bbox="1726 397 1921 587">  <p>29' Wire Harness Qty. 1</p> </div> <div data-bbox="1705 701 1921 750">  <p>Flat Washer Qty. 2</p> </div> <div data-bbox="1705 803 1921 852">  <p>#10-32 Nut Qty. 2</p> </div>	

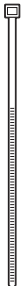
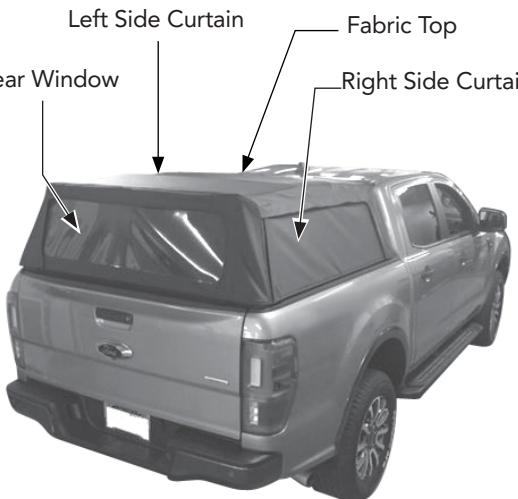
Sections 17 to 22		Patch Loom, Foam Tape, Wire Ties, Top, Window, Side Curtains	
 <p>Female Male</p> <p>Patch Loom For LED Lights Part #593.39 Qty. 1</p>	 <p>Foam Tape Part #595.31 Qty. 1 roll - 24"</p>	 <p>Wire Tie Part #346.58 Qty. 2</p>	 <p>Left Side Curtain Fabric Top Rear Window Right Side Curtain</p>

Section 1 Assemble Side Rails; Remove Paper Backing from Foam Tape

Step 1

Hardware

Step 2

 Set Screw
Part #573.17
Qty. 4

Front Side Rail
Part #594.29 - Left (shown)
Part #594.30 - Right
Qty. 1 of each

Rear Side Rail
Part #588.41 - Left (shown)
Part #588.42 - Right
Qty. 1 of each

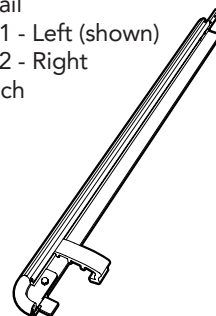
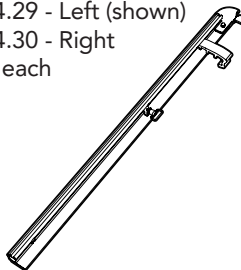

Tools



1/8" Allen
Wrench

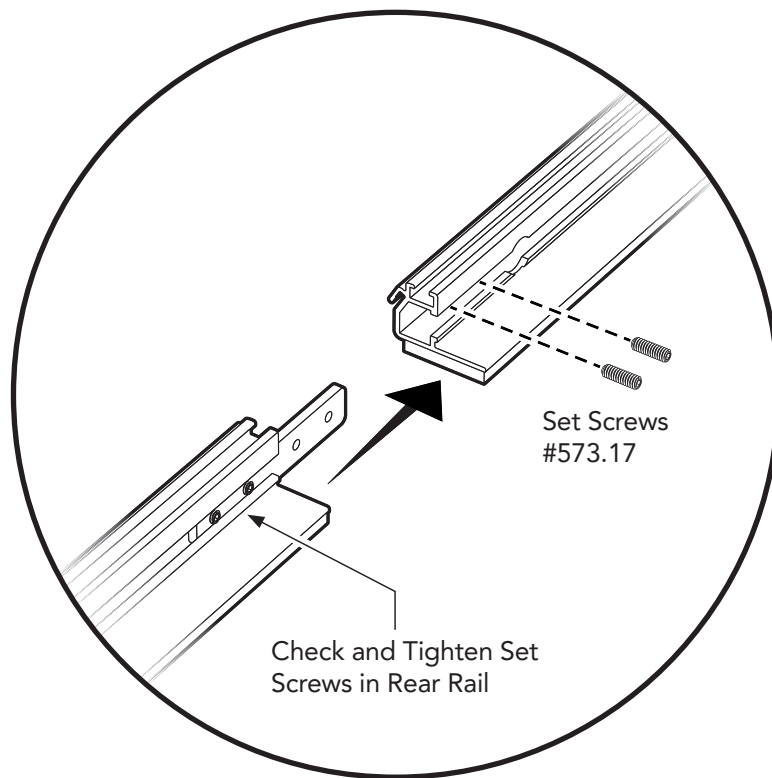
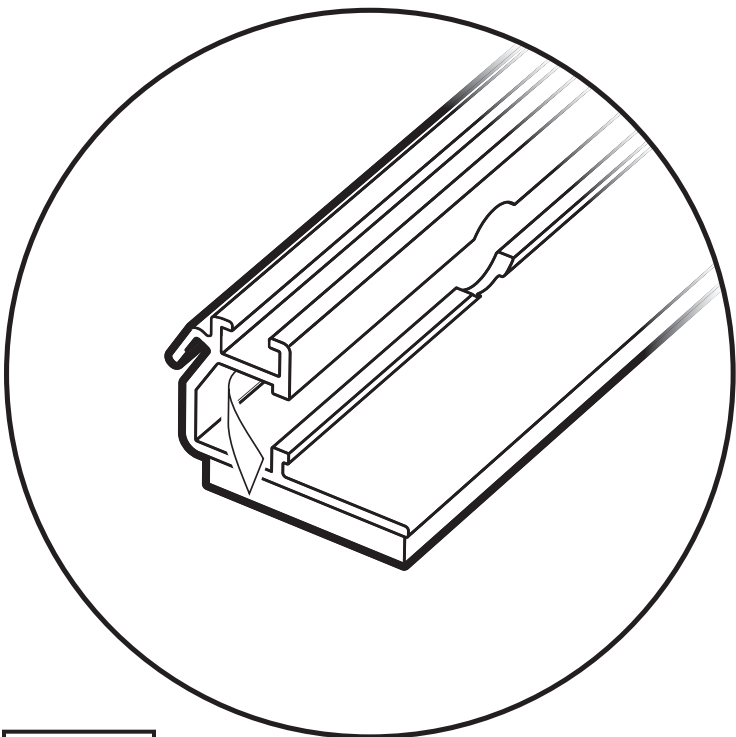

Step 1

Locate the Foam Tape on the Left and Right Side Rails, and remove the paper backing from the foam tape.

Repeat with the both Side Rails.

Step 2

Assemble the Left Front Side Rail #594.29 and the Left Rear Side Rail #588.41.

Slide the rails together, and secure using two set screws #573.17.

Check and tighten the two (2) set screws in the rear rail. Tighten set screws to 35 in-lbs torque.

Repeat with the Right Side Rails.

Section 2 Attach Front & Rear Rails; Attach Side Rail Assemblies

Step 1

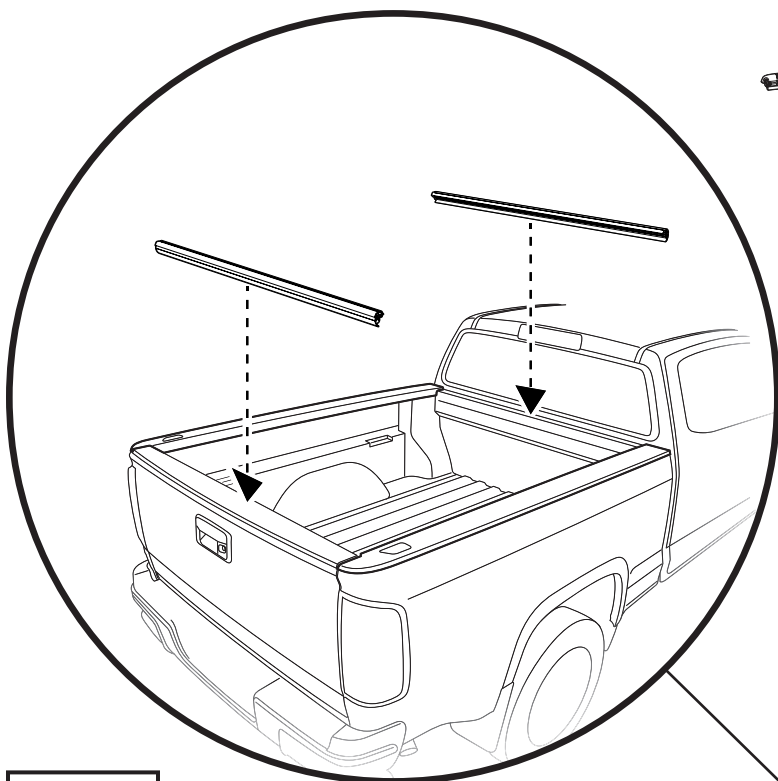

Step 1

Place the Front Rail #584.94 and Rear Rail #584.95 onto the truck bed.

Lay the Rails on top of the truck bed in front, and on top of the plastic bed protector at the rear.

NOTE: The Front Rail is longer than the Rear Rail.

Hardware



Side Rail Assemblies
Qty. 1 of each



Front Rail
Part #584.94
Qty. 1

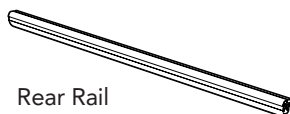

Rear Rail
Part #584.95
Qty. 1

Step 2

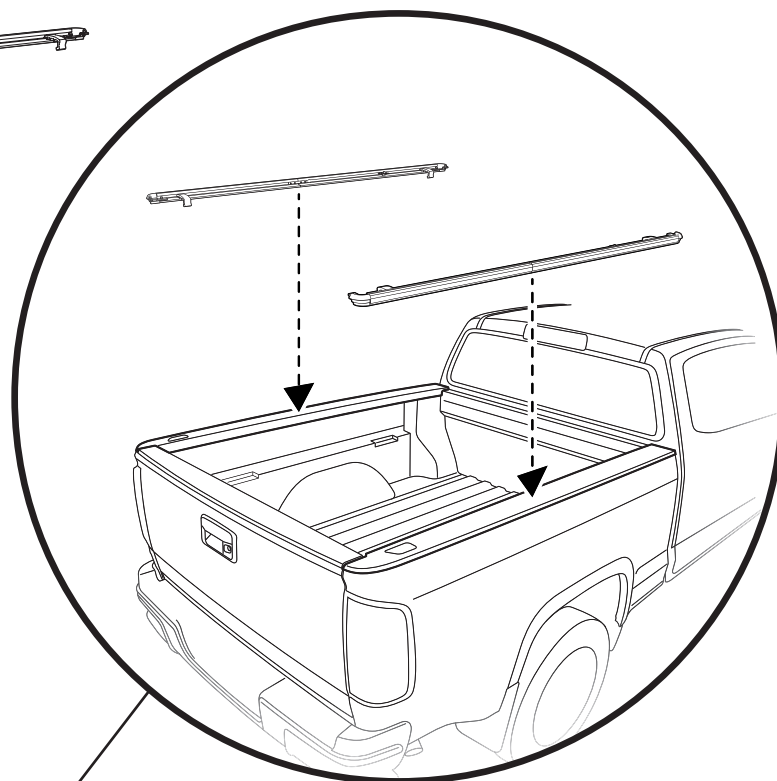

Step 2

Place Side Rail assemblies onto the truck bed. Lay the Rails on top of the plastic bed protectors.

Attach the Side Rails to the Front and Rear Rails.

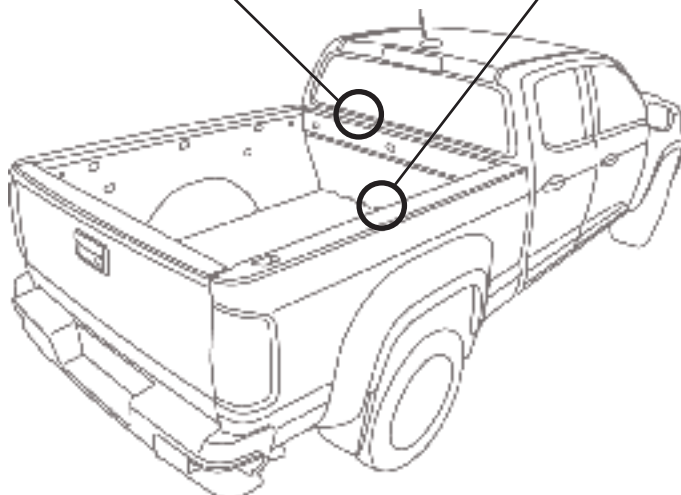

Section 2 Attach Front & Rear Rails; Attach Side Rail Assemblies (cont.)

Step 1

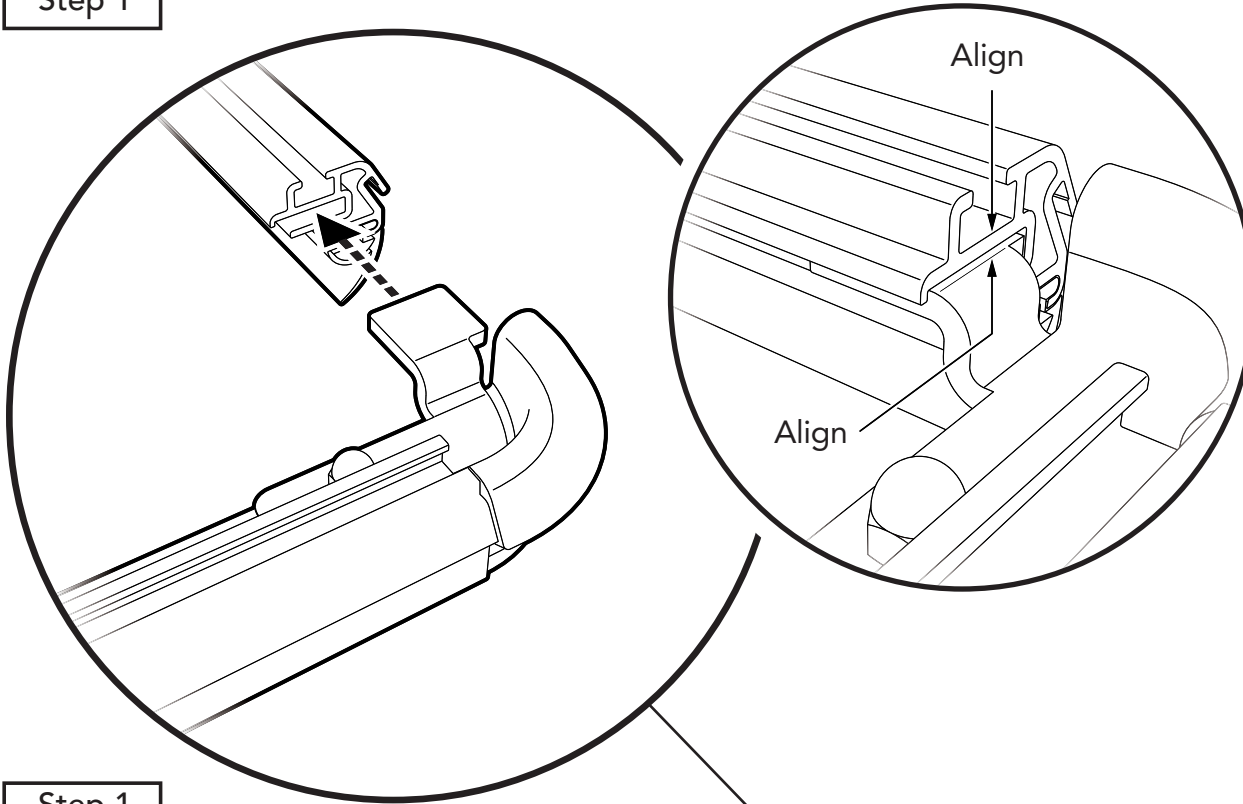

Step 1

Attach the Front and Rear Rails to the Side Rail Assemblies.

Slide the tabs at the front and rear of the Side Rail Assemblies into the slots in the Front and Rear Rails.

Make sure that the ends of the Front Rail and Rear Rail extrusions are aligned with the tongue of the attachment feature, where the tongue bends, and the small corner protrudes.

Step 2

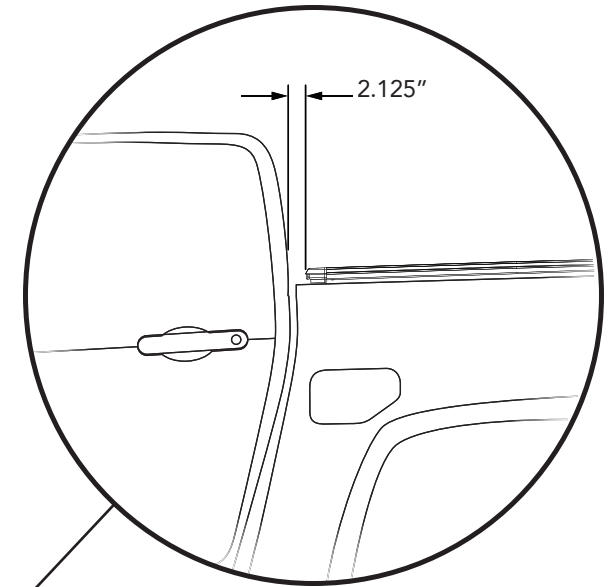

Step 2

Place the outer edge of both side rail corners 2.125" from the back side of the vehicle cab.

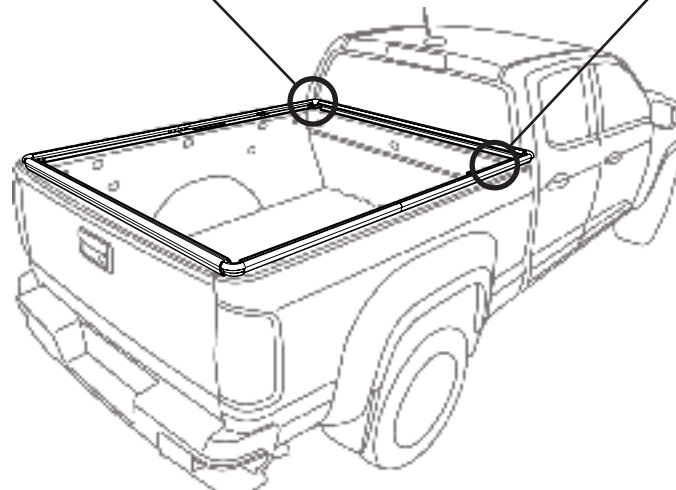

Section 3 Adjust Rails; Install Clamp Pads

Step 1



Step 1

Adjust the Side and Front and Rear Rail assembly right-to-left to center it on the bed width.

Hardware

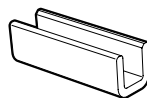

Clamp Pad
Part #577.39
Qty. 2

Step 2

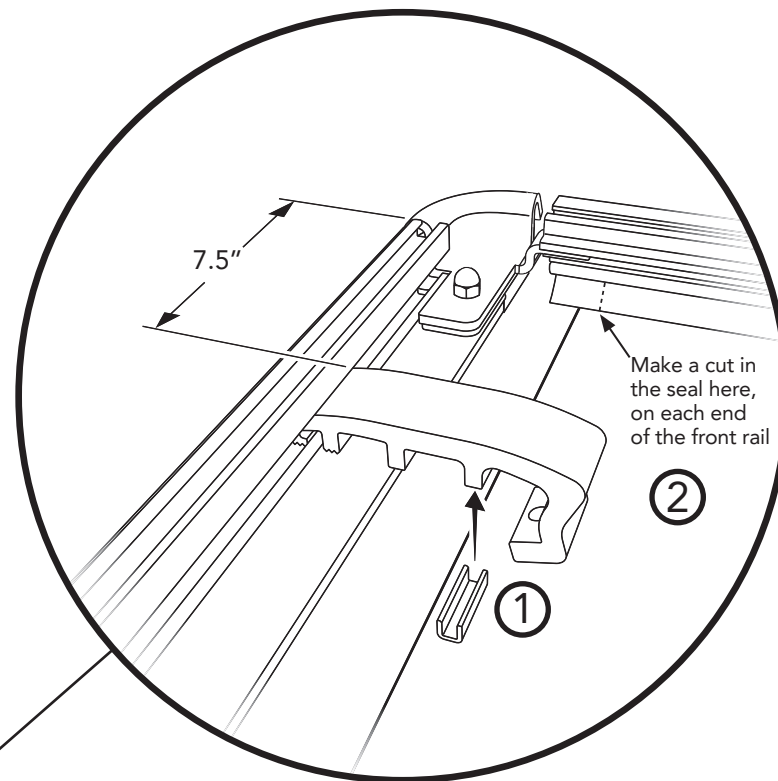

Step 2

① Attach a Clamp Pad #577.39 to each Upper Clamp on the Front Side Rails, on the rib farthest from the side rail.

NOTE: The Clamp Pads must rest on top of the bed rail cap after installation.

The Upper Clamp should be located 7.5" from the end of the Front Side Rail.

② Make two cuts in the seal on the bottom of the front rail, in line with the inner edge of the bed rail cap, so that the seal will lay flat against the bed bulkhead.

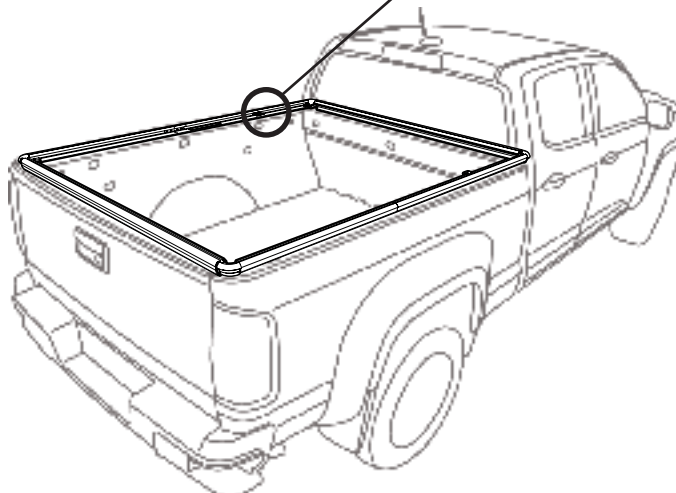

Section 4 Install Rubber Pads; Attach Lower Clamps

Step 1

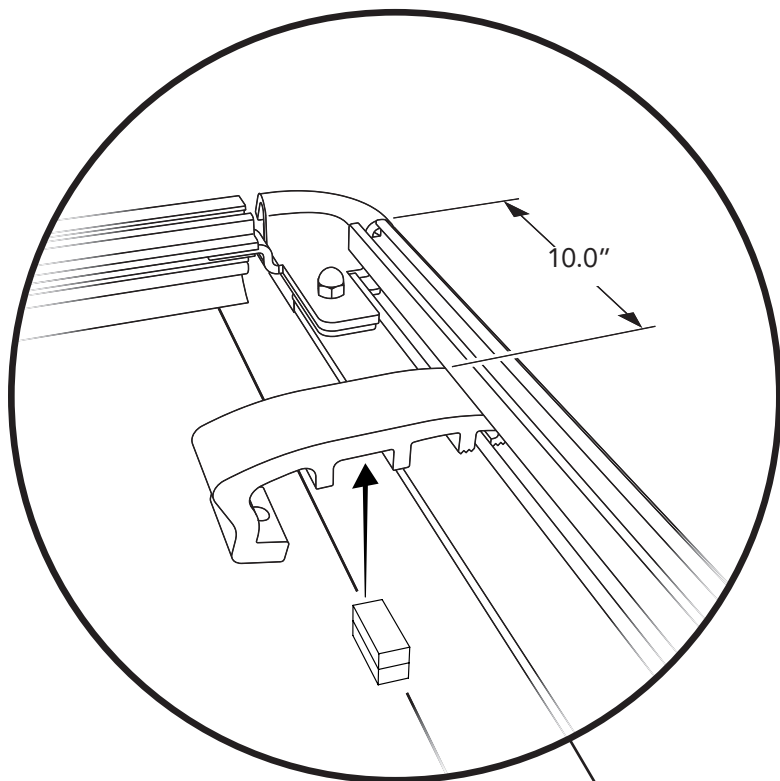

Hardware



Rubber Pad
Part #720035
Qty. 4

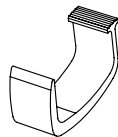

Lower Clamp -
Large
Part #579.23
Qty. 2

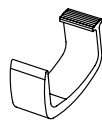

Lower Clamp -
Small
Part #595.34
Qty. 2



Hex Head Bolt
Part #578.39
Qty. 4

Tools



Torque Wrench

Step 1

Attach two (2) Rubber Pads #720035 together, and stick them to the Rear Rail Clamp, between the rib farthest from the rail, and the next rib.

NOTE : The Rubber Pads must rest on top of the bed rail cap after installation.

The Rear Clamps should be located 10.0" from the end of each Rear Side Rail.

Step 2

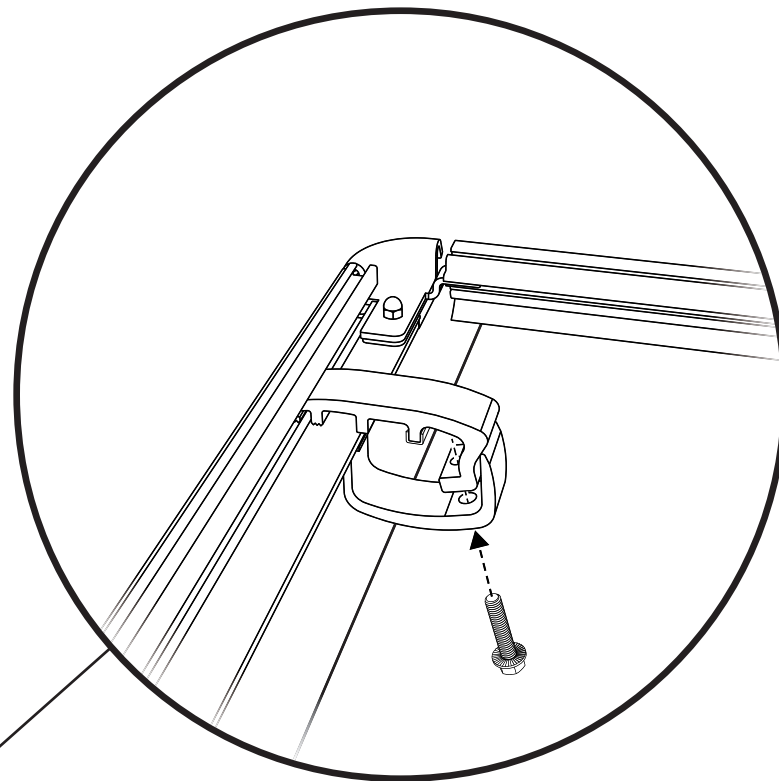

Step 2

Attach Large Lower Clamps #579.23 to the rear pre-assembled Upper Clamps on the Side Rails, using one (1) Hex Head Bolt #578.39 for each clamp.

Attach Small Lower Clamps #595.34 to the front pre-assembled Upper Clamps on the Side Rails, using one (1) Hex Head Bolt #578.39 for each clamp.

Check alignment of the Rail Assembly and tighten all bolts.

Tighten all bolts to 55 in-lbs torque.

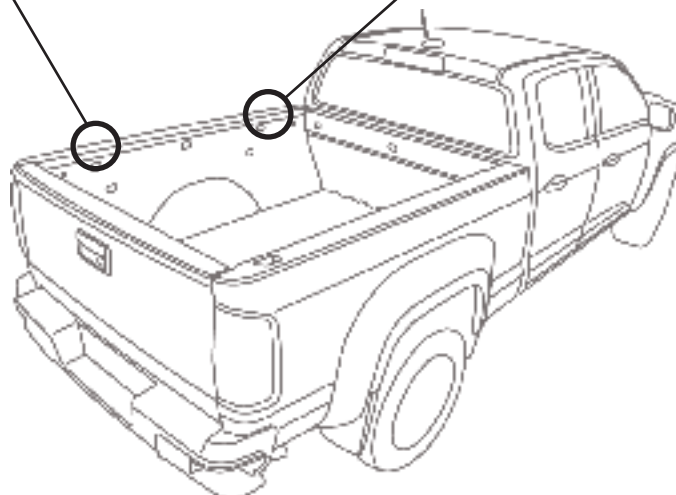

Section 5 Assemble Bows

Step 1

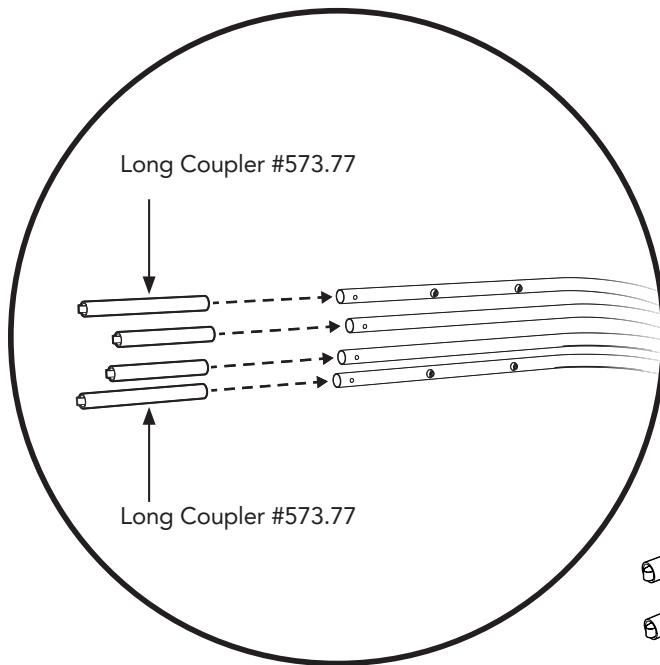

Step 1

Attach Bow Couplers #573.77 and #573.79 to the Passenger Side Bow Stack #579.38.

Insert Long Couplers #573.77 into the outer bows #1 and #4.

Insert Short Couplers #573.79 into the inner bows #2 and #3.

For Easier Installation:

Slide all bows and couplers together before snapping the spring clips into the holes in the bows.

Hardware

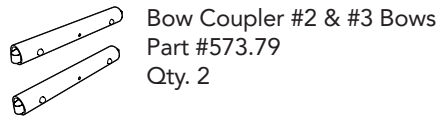
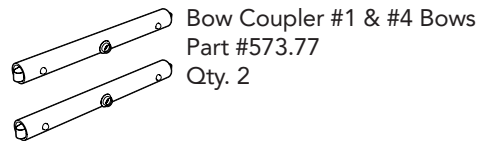
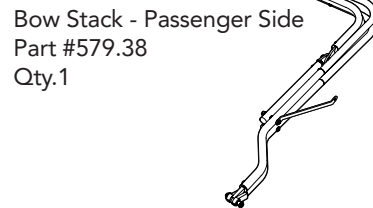
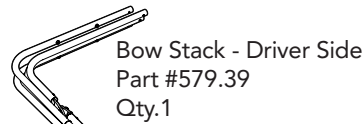

Step 2

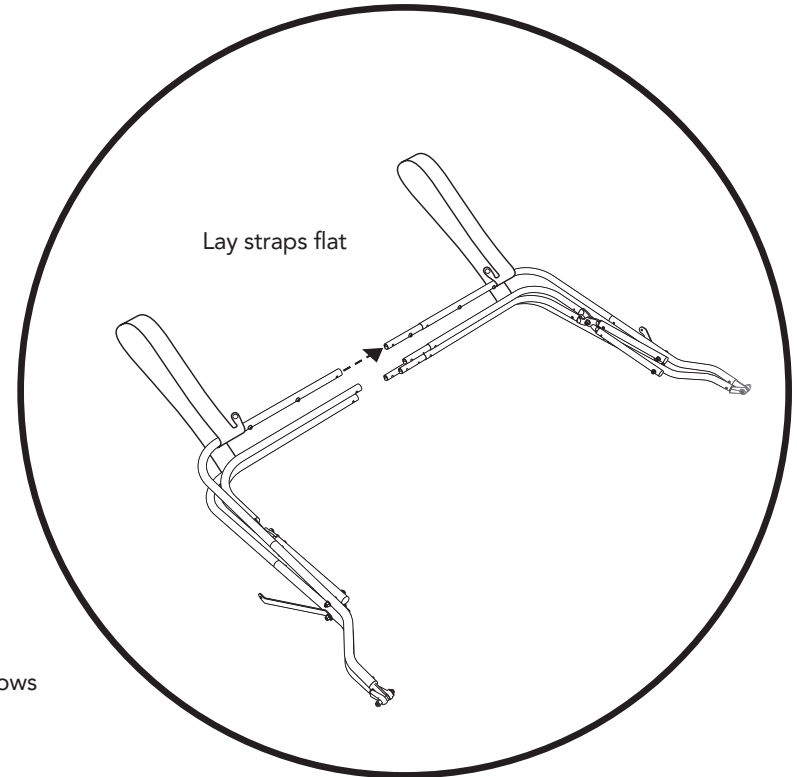

Step 2

Attach Driver Side Bow Stack #579.39 to Passenger Side Bow Stack #579.38.

Bow Stacks attach using the Couplers installed in Step 1.

Slide the Couplers installed in the Passenger Side Bow Stack into the ends of the bows on the Drivers Side Bow Stack.

NOTE: Before attaching couplers to bow stacks, make sure to pull the bond coat straps out and away from the bows, and lay them flat.

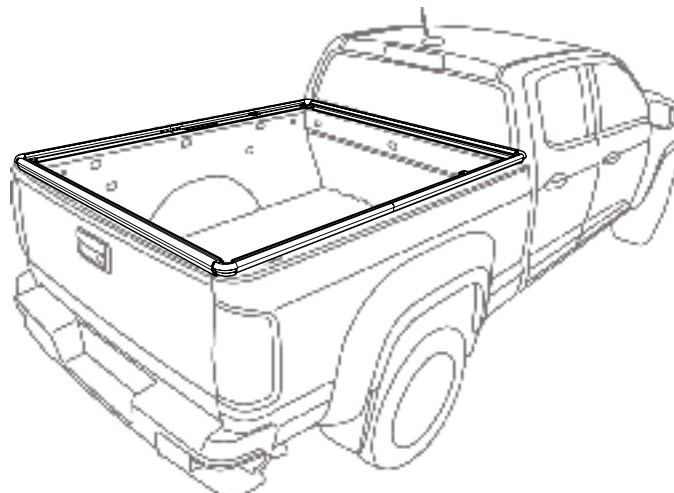

Section 6 Install Bow Assembly

Step 1

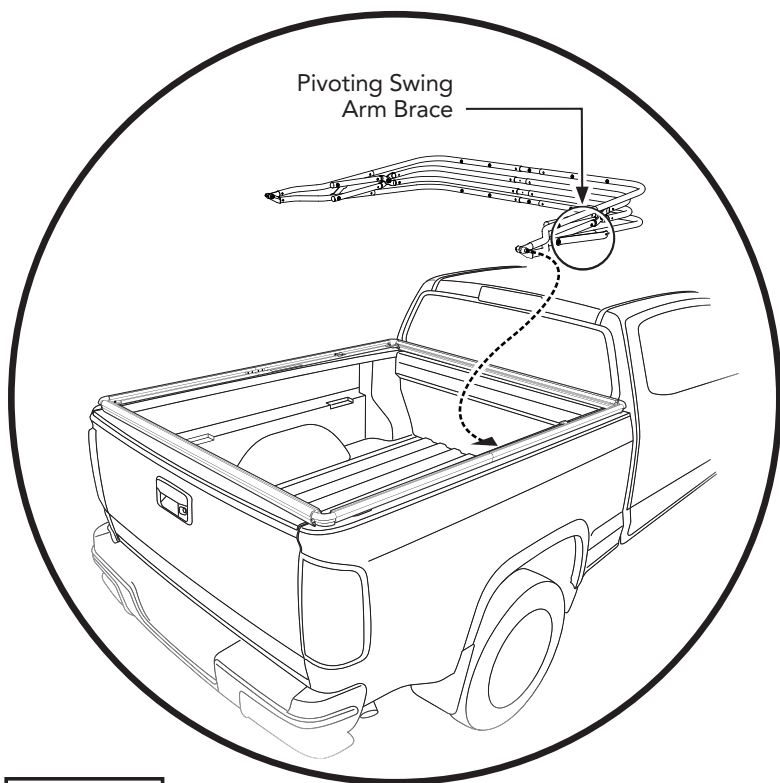

Details

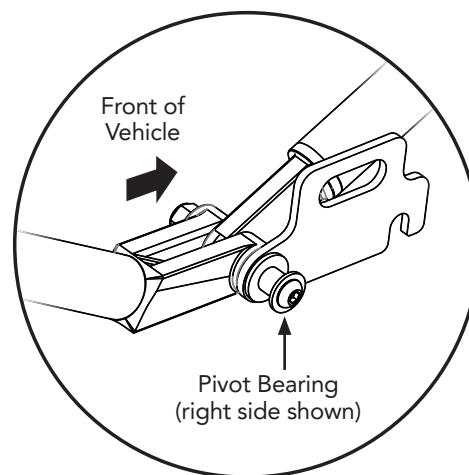

Details

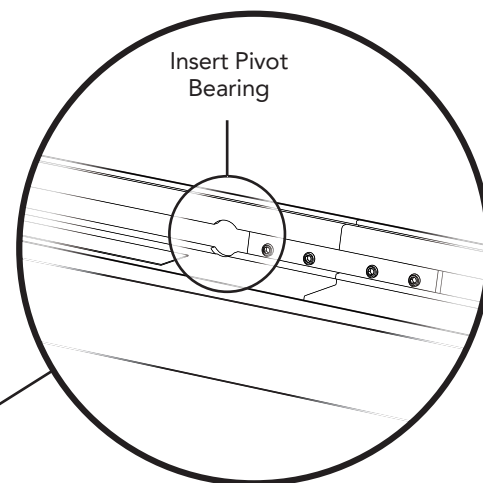

Step 1

NOTE: Two People Are Required for This Portion of the Installation Process.

Place the folded Bow Assembly on the Side Rails. Make sure that the pivot swing arm braces are on the lowest bow.

Insert the Pivot Bearings into the receiving holes in the inside of the side rails

See Details.

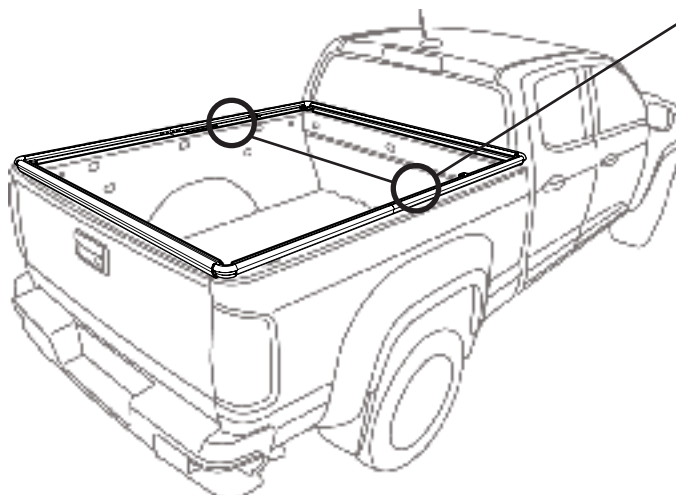

Section 7 Unfold Bows; Attach Pivot Arm Braces; Engage Locking Levers

Step 1

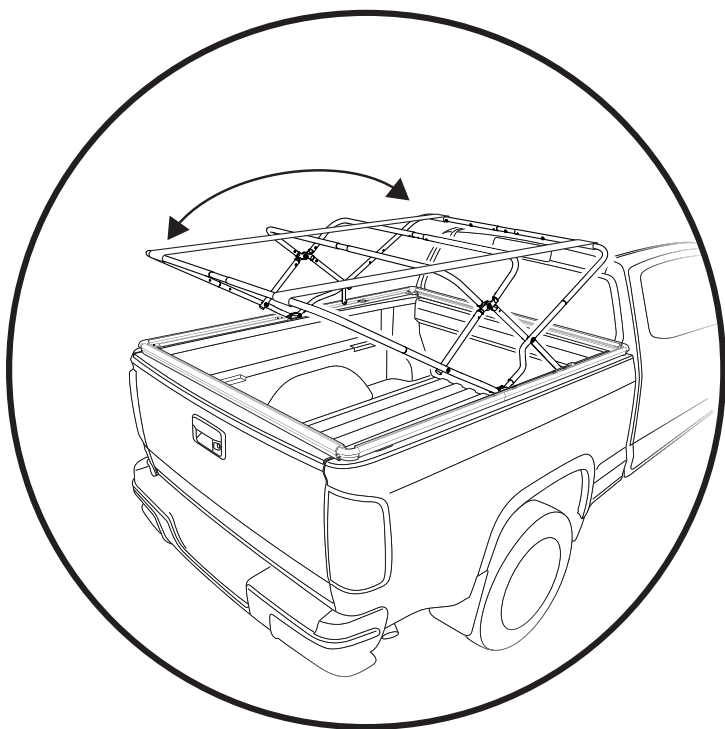

Step 1

Unfold the Bow Assembly.

Step 2

- ① Pull back on the Pivot Knuckle release knob;
- ② Snap the Pivot Arm Brace into place, on both sides of the truck.

Step 2

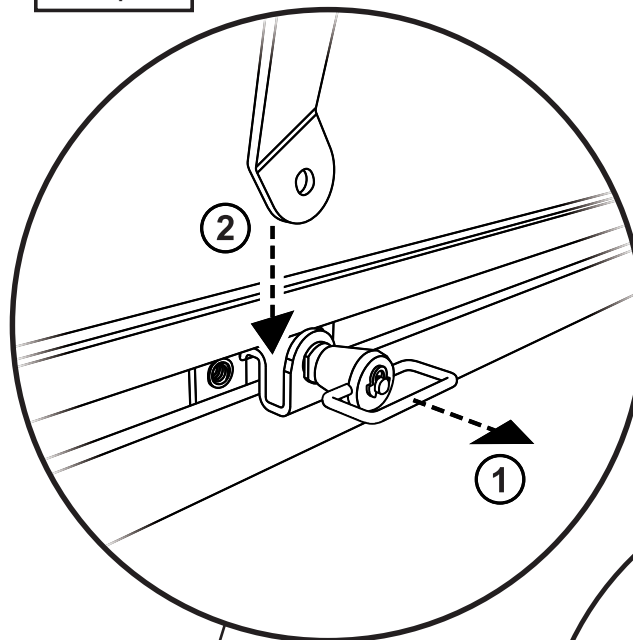

Step 3

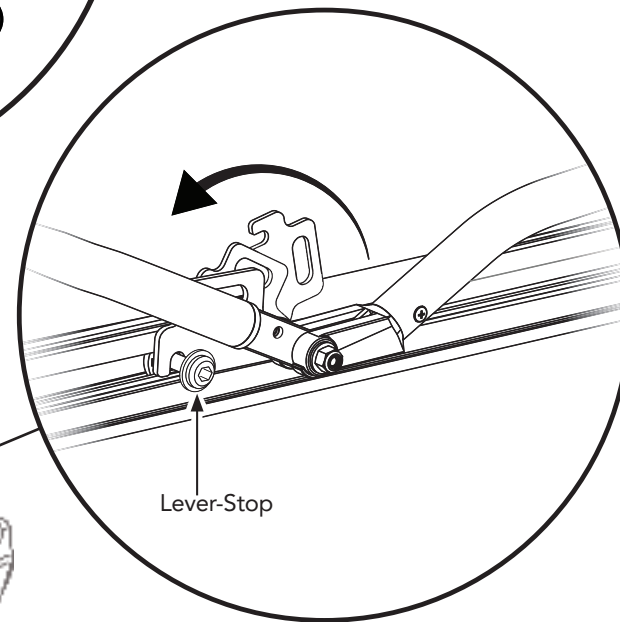

Step 3

Engage the Locking Lever on both sides of the truck.

NOTE: The Lever-Stop Assemblies are pre-installed at the factory at 29.0" from the front edge of each Side Rail.

Section 8 Lay Folded Top Fabric on Bows; Unfold Top Fabric

Step 1

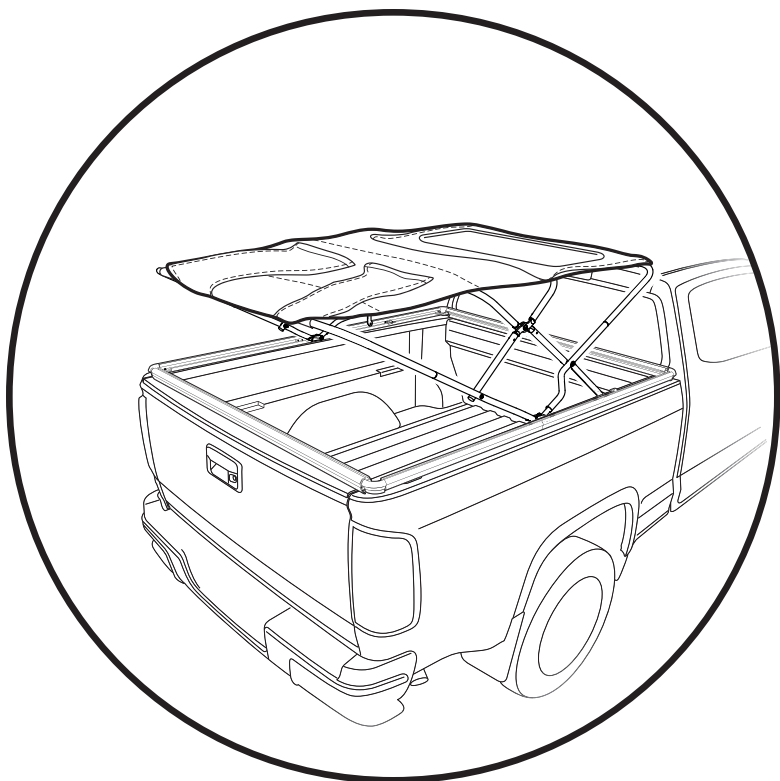

Step 1

Place the folded Soft Top onto the unfolded Bow Assembly.

Step 2

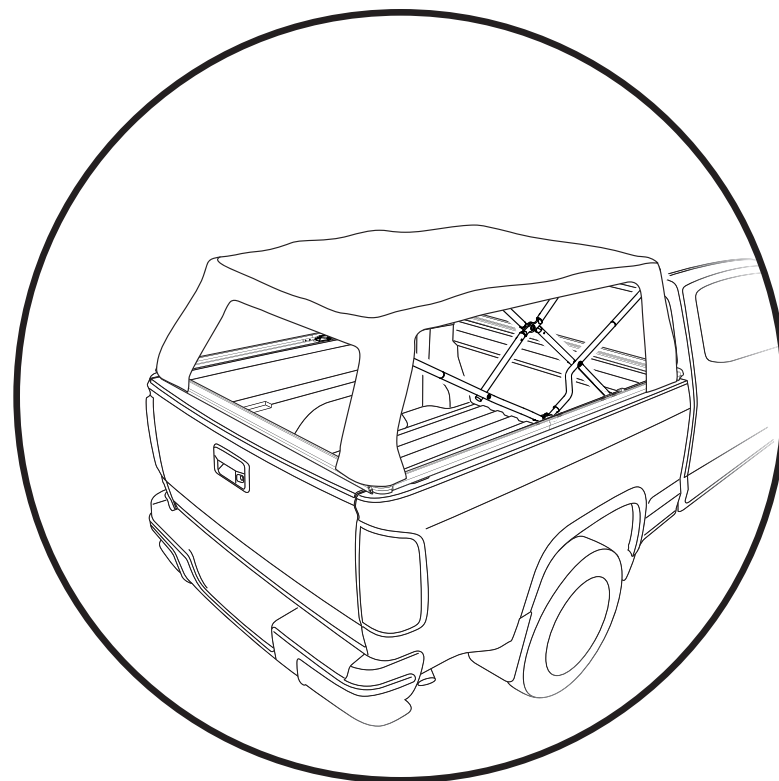

Step 2

Unfold the front and back of the Top over the #1 and #4 Bows.

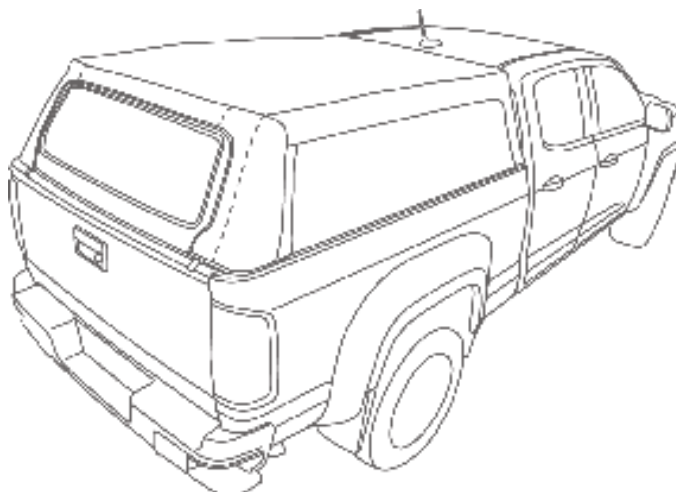

Section 9 Tighten Adjustment Screws; Install Side Curtains

Step 1

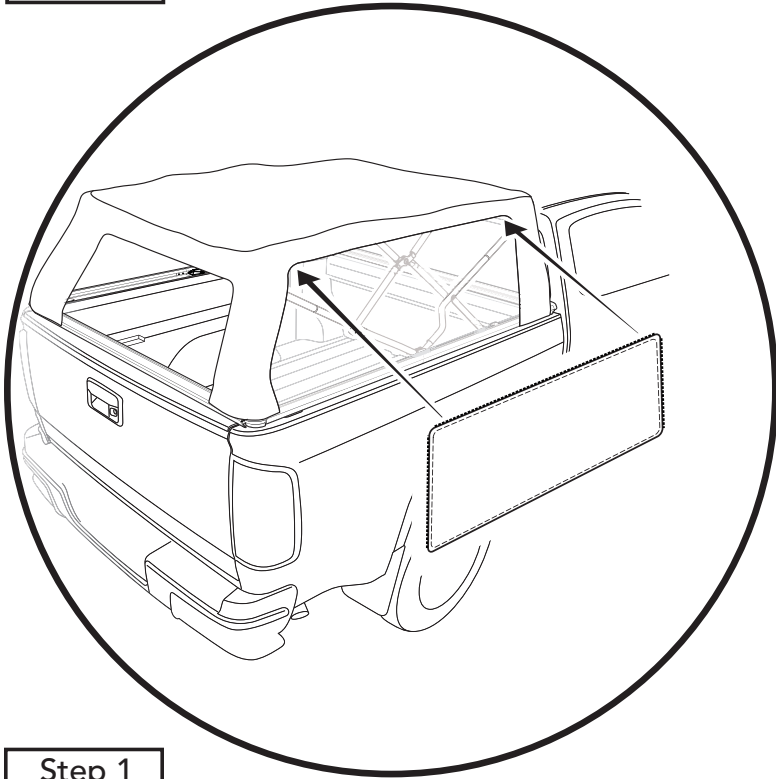

Step 1

For easier access to the zippers, you may want to lift the corners of the top onto the roof fabric.

Zip the Rear Window and Side Curtains into place.

Start with the zipper along the top edge of each panel, and then follow with the side zippers. For ease of installation, start each zipper only about 6".

Once all zippers are started, flip the rear corners into the rail, then zip all zippers completely shut.

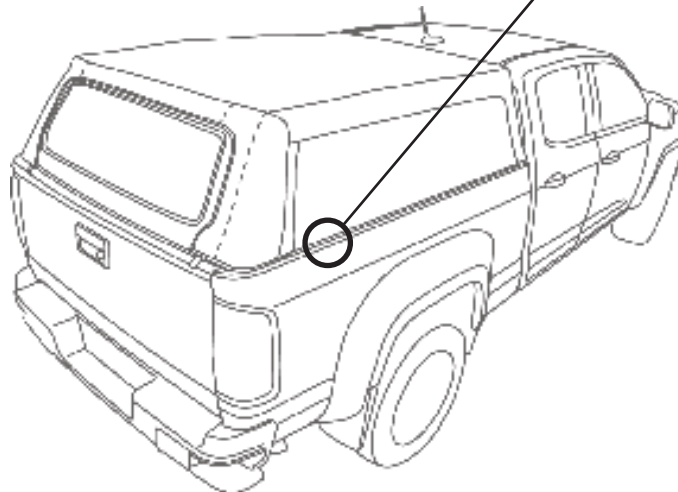

Step 2

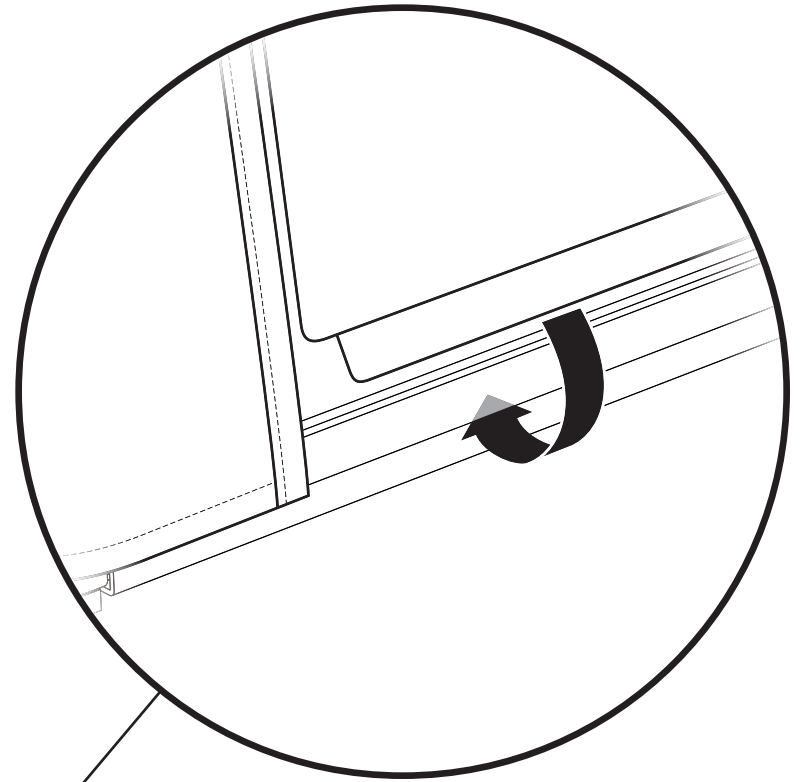

Step 2

Tuck the plastic tab along the bottom edge of each Side Curtain into the slot along the side of each Side Rail.

Tuck the plastic tab along the bottom of the Rear Window into the slot along the side of the Rear Rail.

Section 10 Secure Top Fabric to Bows

Step 1

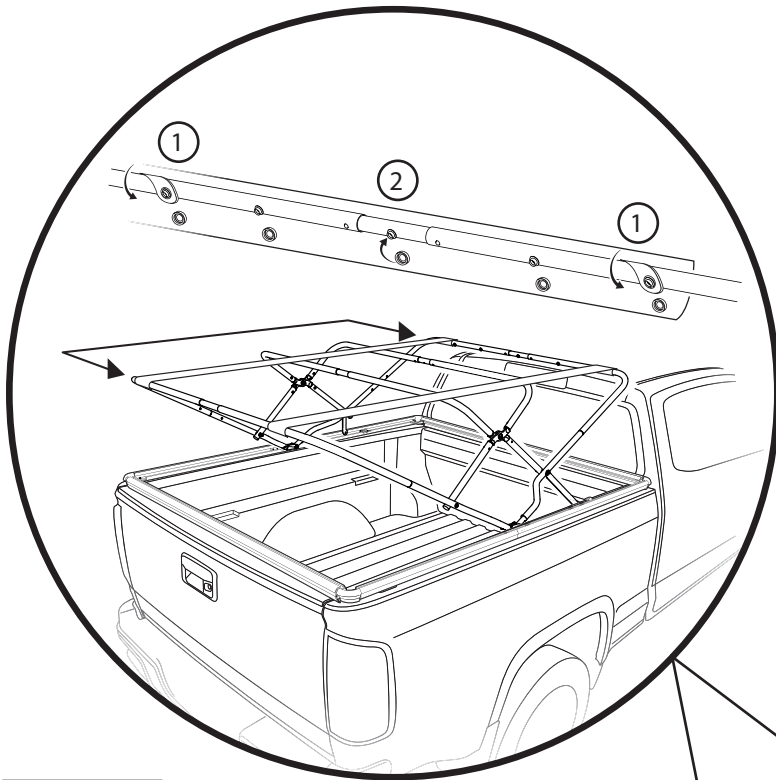

Step 1

From inside the truck bed:

- ① Wrap the small flaps with holes over the outer-most snaps on the #1 bow (Bow closest to the truck cab).
- ② Wrap the fabric flap around the #1 Bow and snap all five snaps to secure the fabric to the Bow.

NOTE: Secure the outer snaps before securing the center snaps.

Repeat for the #4 Bow (Bow closest to the truck tailgate).

Step 2

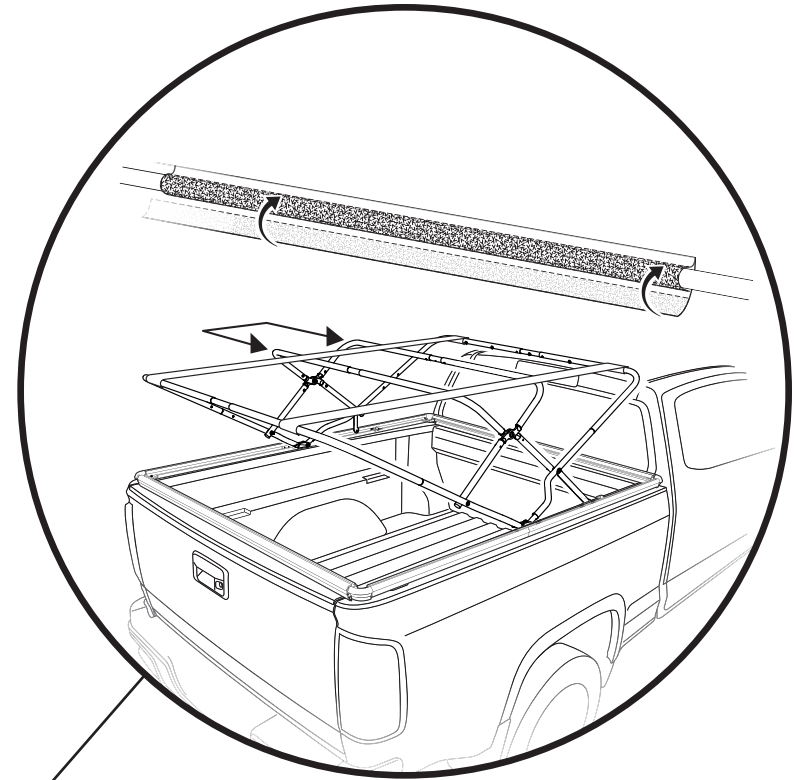

Step 2

From inside the truck bed:

Wrap the fabric flaps with hook-and-loop around the #2 and #3 bows (the two middle bows) to secure the top fabric to these Bows.

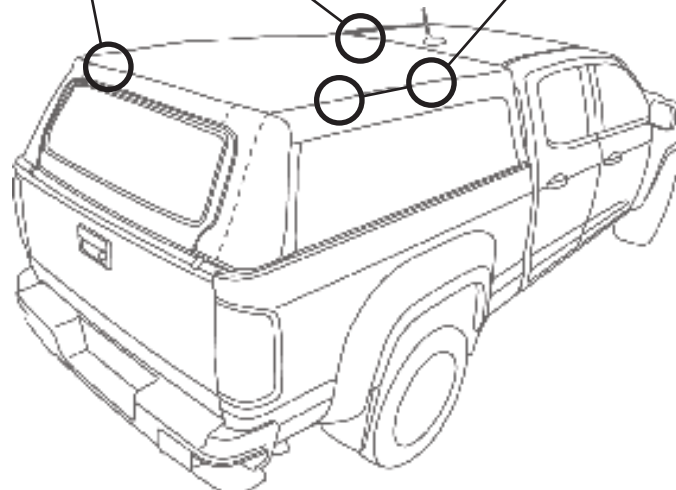

Section 11 Slide Front Rail into Front Window

Step 1

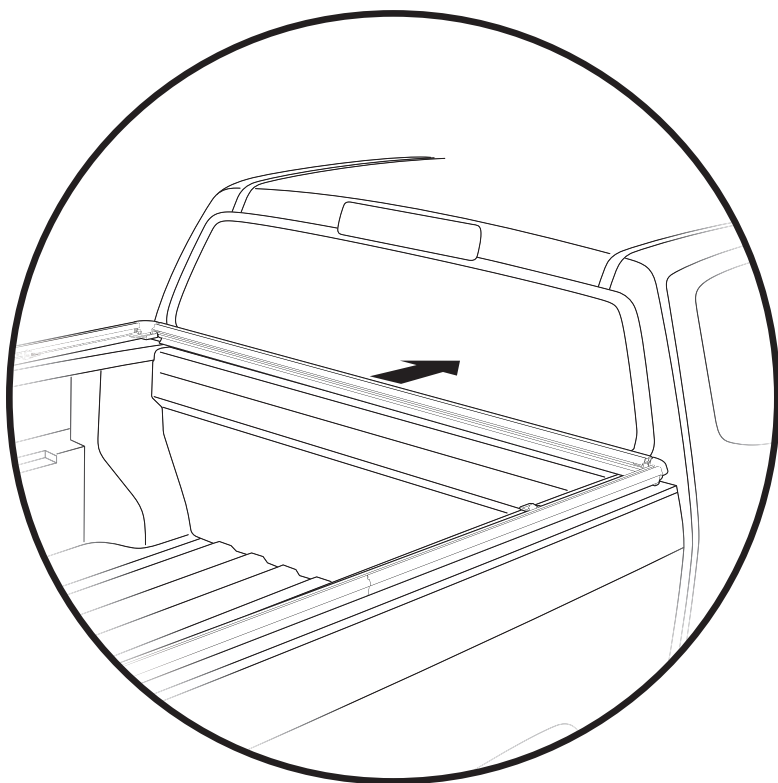

Step 2

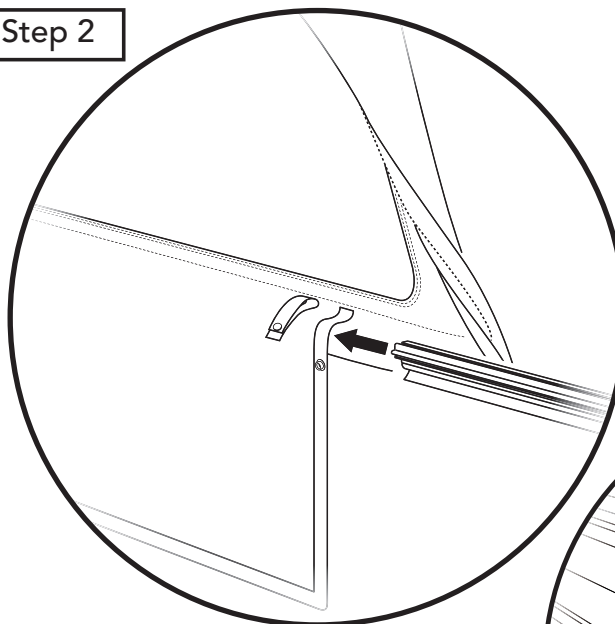

Detail

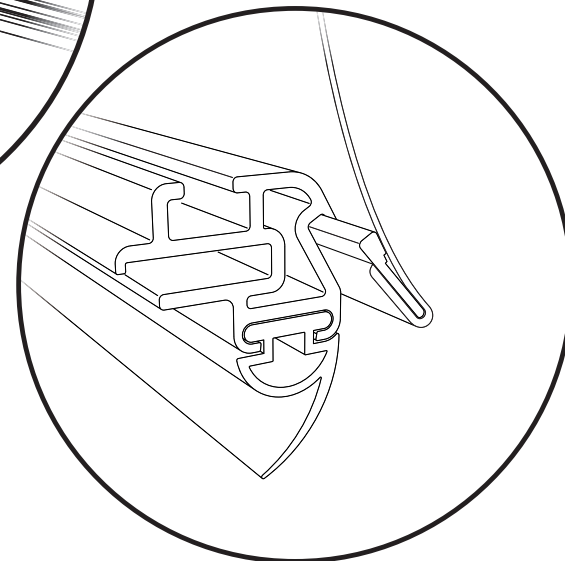

Step 1

Remove the front rail, by sliding it toward the front of the truck bed.

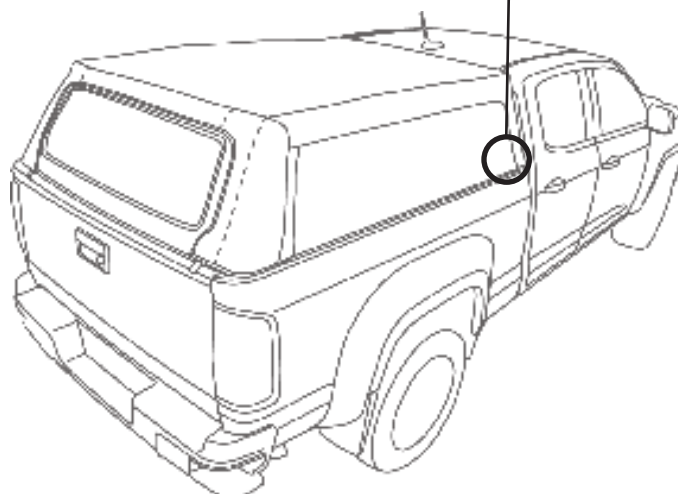

Step 2

Slide the front rail onto the plastic retainer at the bottom of the front window. The rail should go under the large flap.

See Detail.

Section 12 Tuck Plastic Tabs into Rails

Step 1

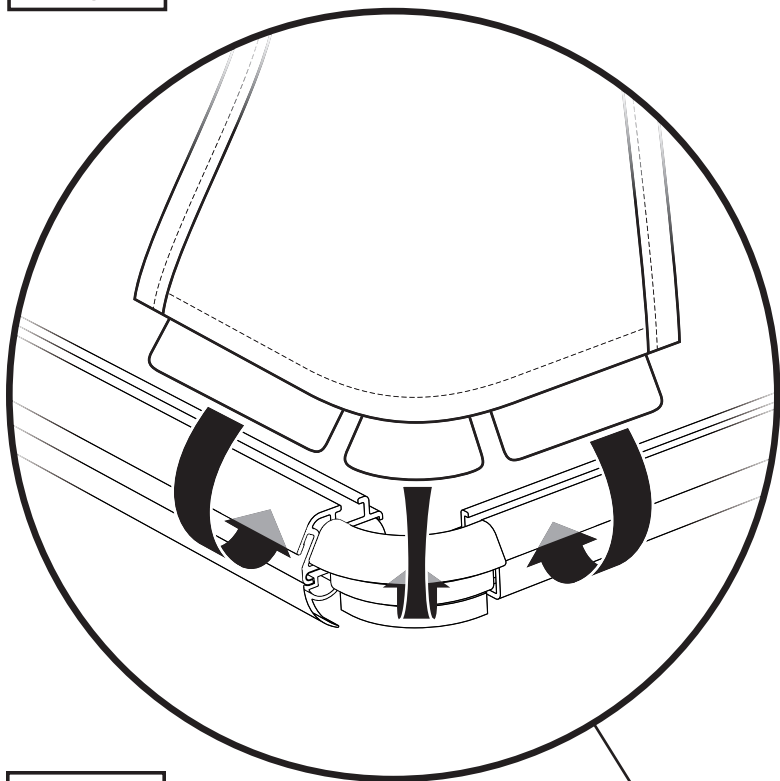

Step 1

Tuck the plastic tabs at the bottom of each corner of the top into the slots in the Side Rails and Front and Rear Rails.

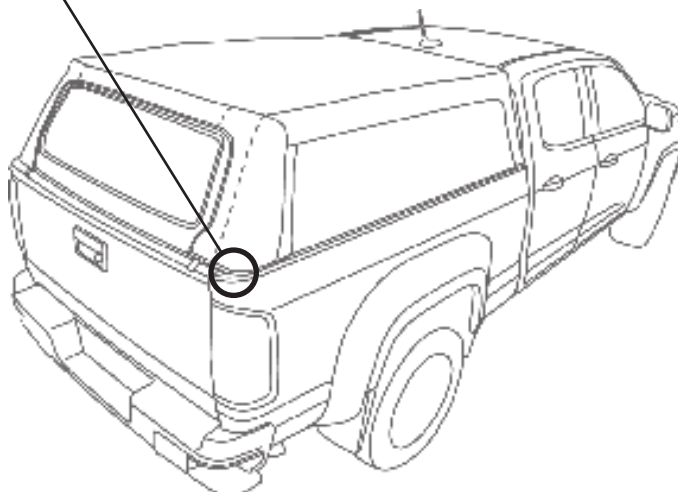

Section 13 Install Center High-Mount Stop Light

Step 1

Hardware Kit #576.71

Step 2

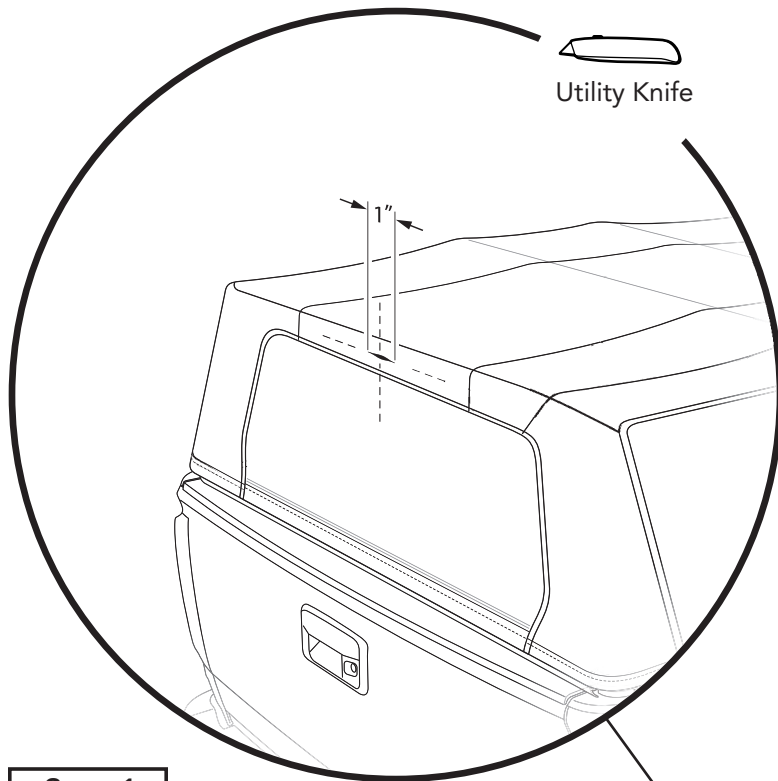

Utility Knife

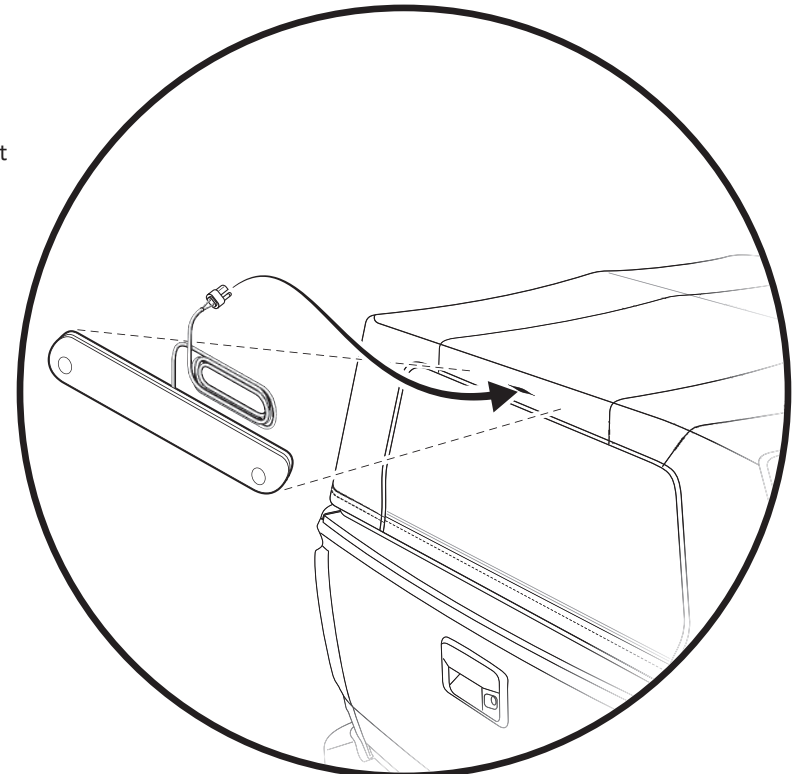
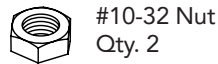
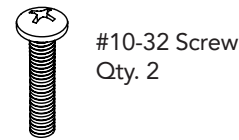
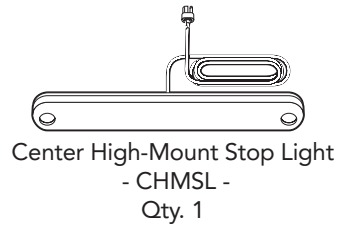

Step 1

Using a utility knife, cut a 1" wide slit through both layers of fabric in the area above the middle of the rear window, and in the vertical center of the fabric.

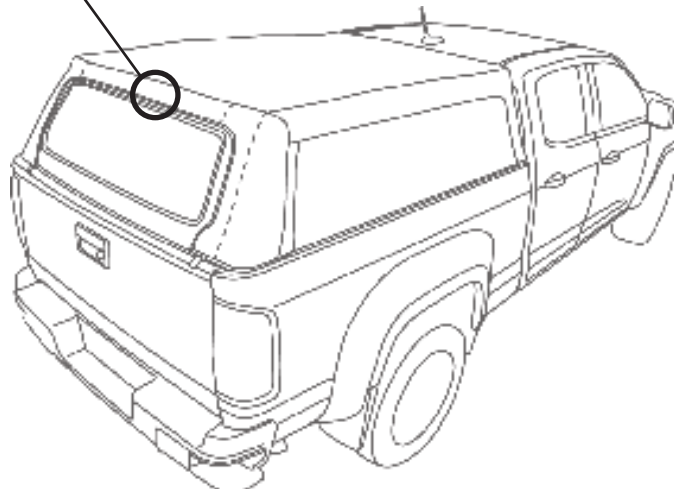

Step 2

Feed the connector end of the CHMSL wire harness through the slit in the top fabric, and pull the wire all the way through both layers of fabric.

Make sure that the light is centered, straight and level, and attach the Stop Light to the top fabric using two (2) 10-32 Screws, two (2) Flat Washers and two (2) 10-32 Nuts. The Nuts and Flat Washers go on the inside of the fabric.

You'll need to pierce the fabric for the screws to go through.

Section 14 Feed Wire Harness Through Sleeves

Step 1

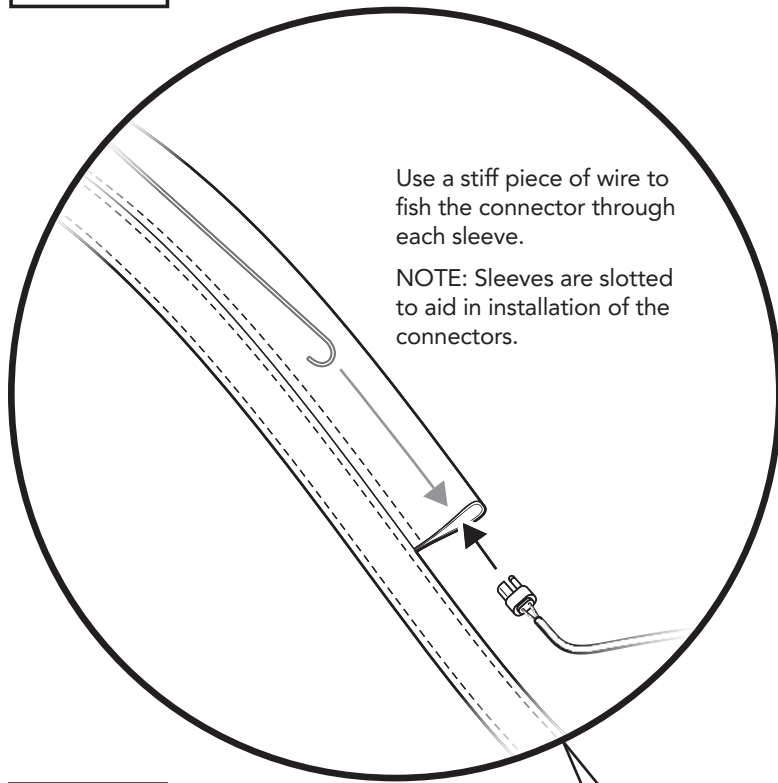

Detail

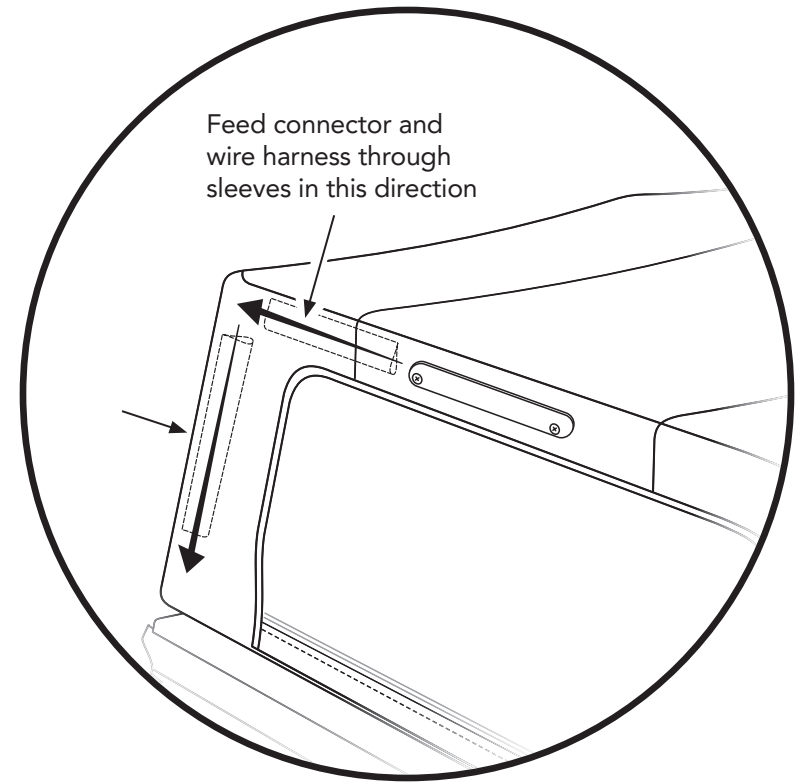

Step 1

Feed the connector and wire harness through the fabric sleeves on the inside of the top.

The sleeves run across the top and down the rear corner of the top fabric.

Use a stiff piece of wire or a rod to fish the connector through the sleeves.

See Detail.

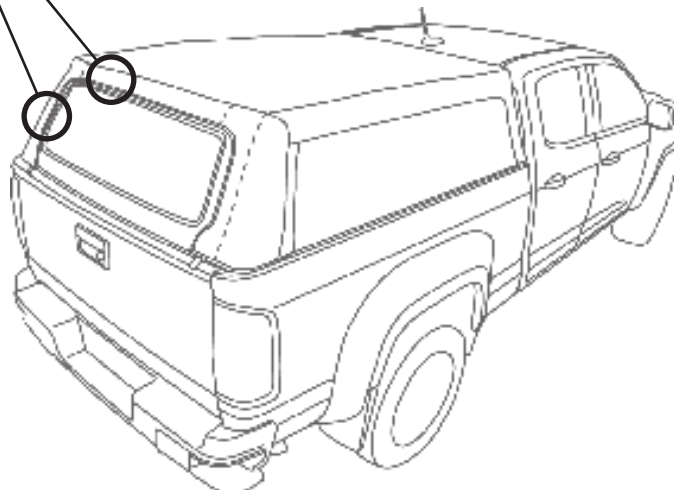

Section 15 Flip Rear Driver Side Seatbacks Forward; Remove CHMSL

Step 1

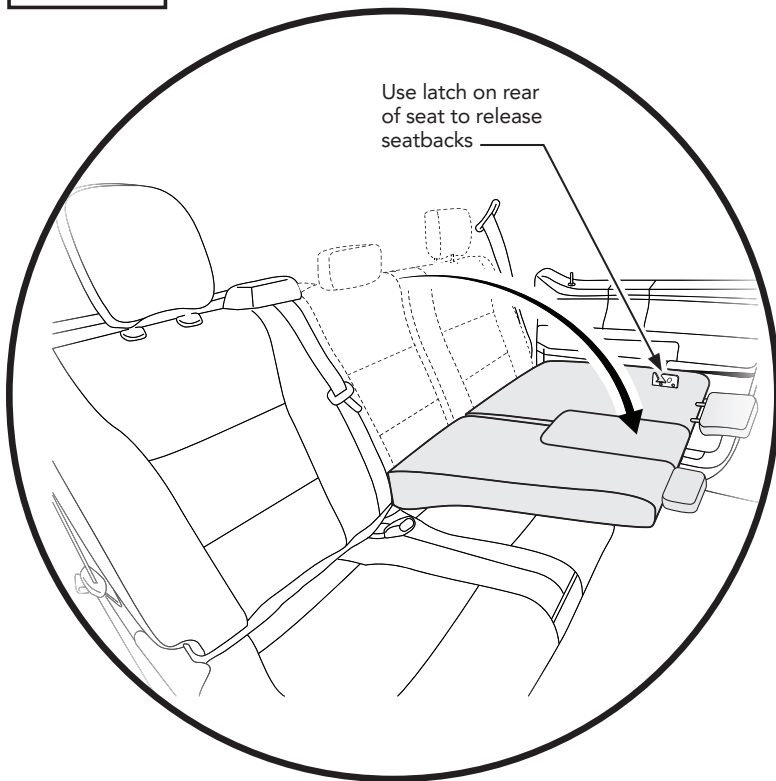

Step 1

Use the latch on the rear of the driver side rear seatback to release the driver side and middle seatbacks, and flip both seatbacks forward.

Tools

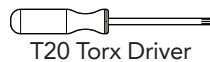

Step 2

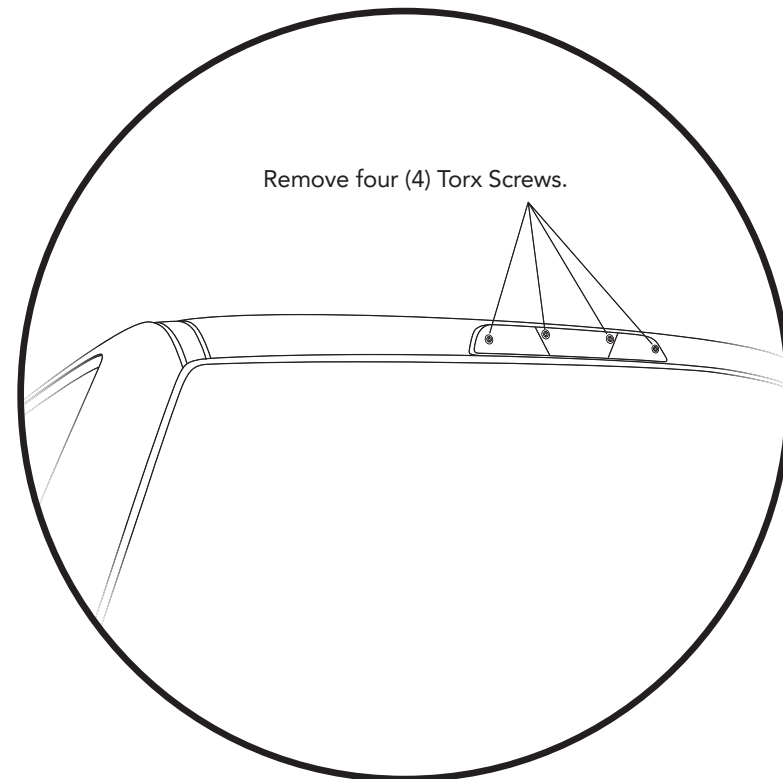

Step 2

Use a T20 Torx Driver to remove the 4 screws that attach the Center High-Mounted Stop Light to the vehicle cab, and remove the CHMSL.

The light housing will remain attached to the wire harness - do not cut any wires at this time.

Section 16

Install 29' Wire Harness

Step 1

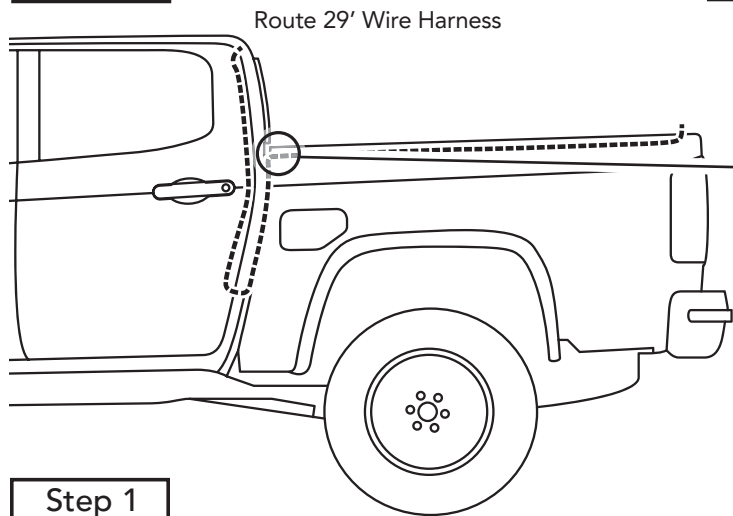

Detail A

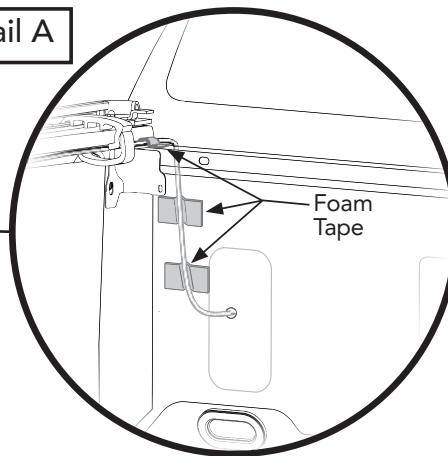

Detail B

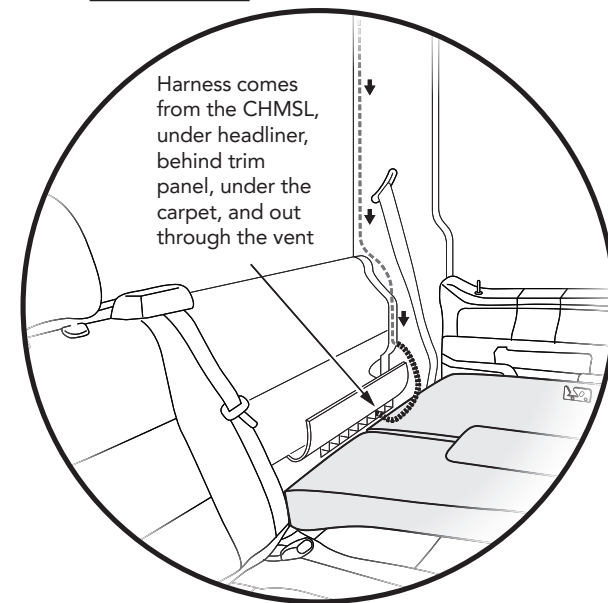

Step 1

Route the 29' Wire Harness from the interior side of the CHMSL, above the headliner, down the rear driver side pillar, under the carpet, through the cab vent, into the vehicle bed, and along the top of the bed, underneath the bed rail cap. See Detail B.

NOTE: Be sure the wire harness is secured between the vehicle cab and bed. Cut three 2" pieces of the Foam Tape #595.31 and use the tape to fasten the wire to the back side of the vehicle bed, and to the top of the bed as shown in Detail A.

Tools

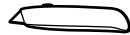

Utility Knife

Hardware

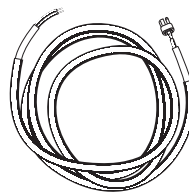

29' Wire Harness
Qty. 1



Foam Tape
Part #595.31
2" Pieces

WARNING



Wire Harness must be routed clear of all airbags.

Section 17

Attach 29' Wire Harness to Patch Loom; Attach Patch Loom; Secure to cab

Step 1

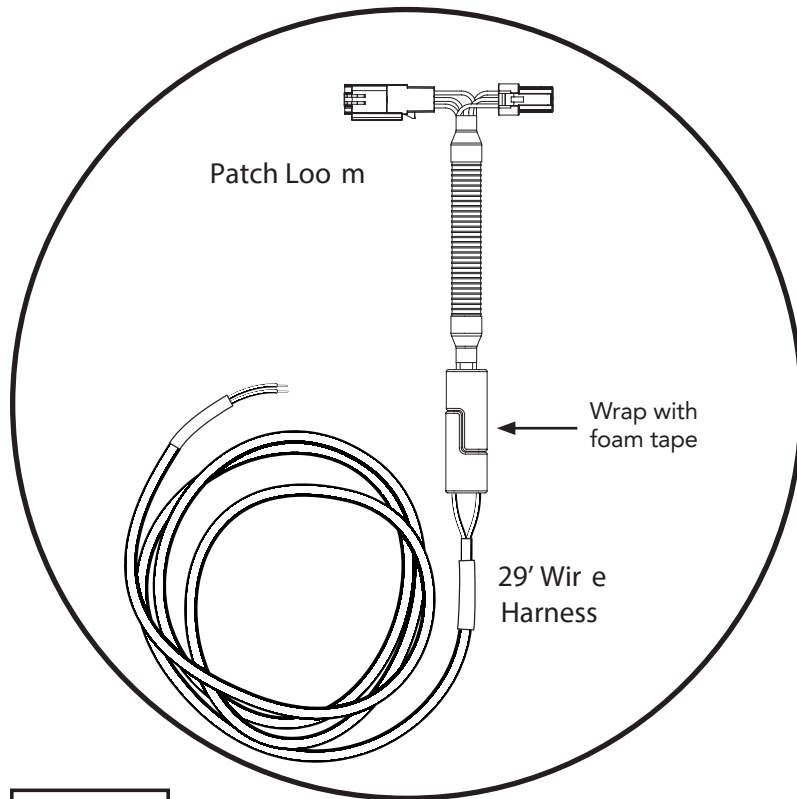

Step 1

From outside the vehicle, connect the Vehicle Patch Loom #593.39 to the 29' Wire Harness.

On the 29' connection to Patch loom, use 2" pieces of foam tape #595.31 and wrap the foam tape around the connection to secure the connection together.

Hardware

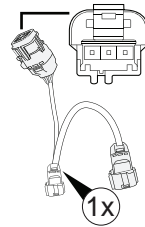

Patch Loom
1x



Foam Tape
Part #595.31
2" Pieces



Wire Tie
Part #346.58
Qty. 2

NOTE: There will be leftover CHMSL wire after running wire to the rear of the vehicle bed. On the inside of the cab, roll the wire bundle up and use wire tie #346.58 to secure it.

The wire bundle can be tucked behind the carpet or trim behind the rear seats.

Step 2

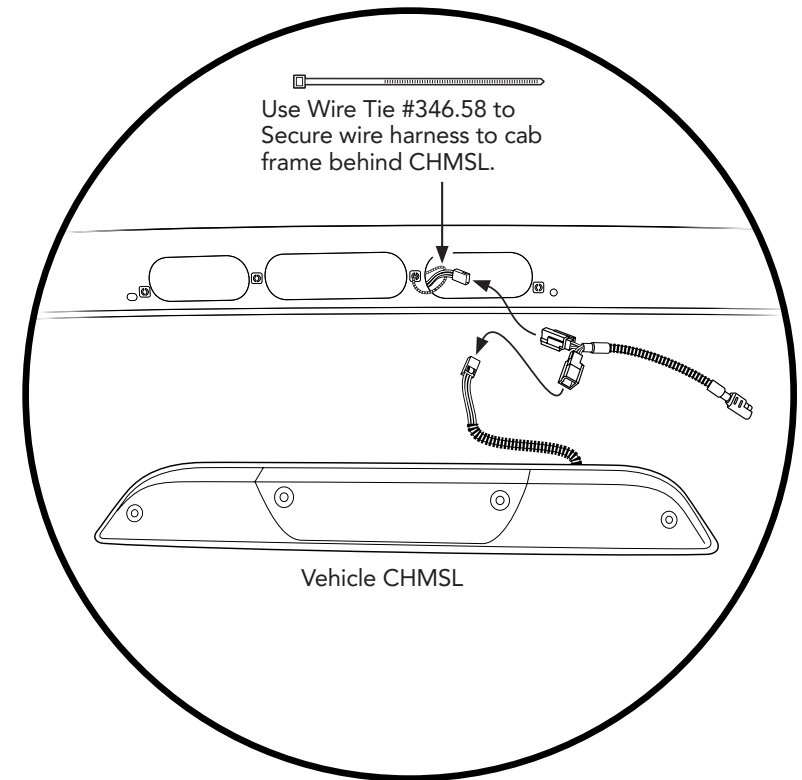

Step 2

Unplug the connector between the CHMSL and the wire harness that goes through the vehicle cab where the CHMSL was removed.

Plug both connectors on the Patch Loom into the connectors that you just unplugged coming from the vehicle CHMSL harness.

Use Wire Tie #346.58 to Secure the wire harness to the cab frame behind the CHMSL.

Section 18 Re-Attach CHMSL to Vehicle

Step 1

Tools

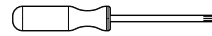

T20 Torx Driver

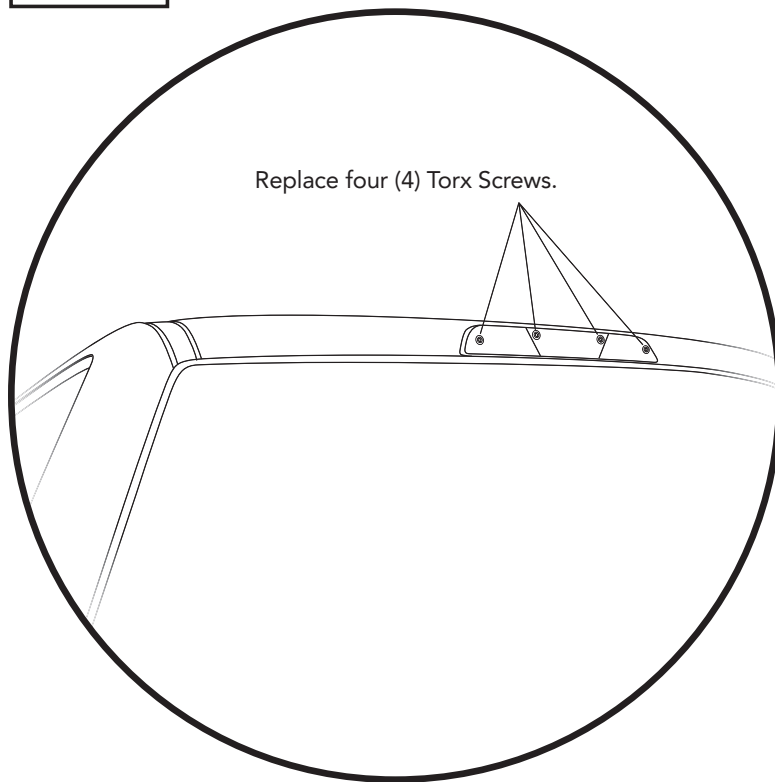

Step 1

Find the four (4) T20 Torx screws you removed earlier, and re-attach the Center High-Mounted Stop Light (CHMSL) to the vehicle cab.

Section 19 Route Wire Harness; Plug CHMSL Wire Harness Connectors Together

Step 1

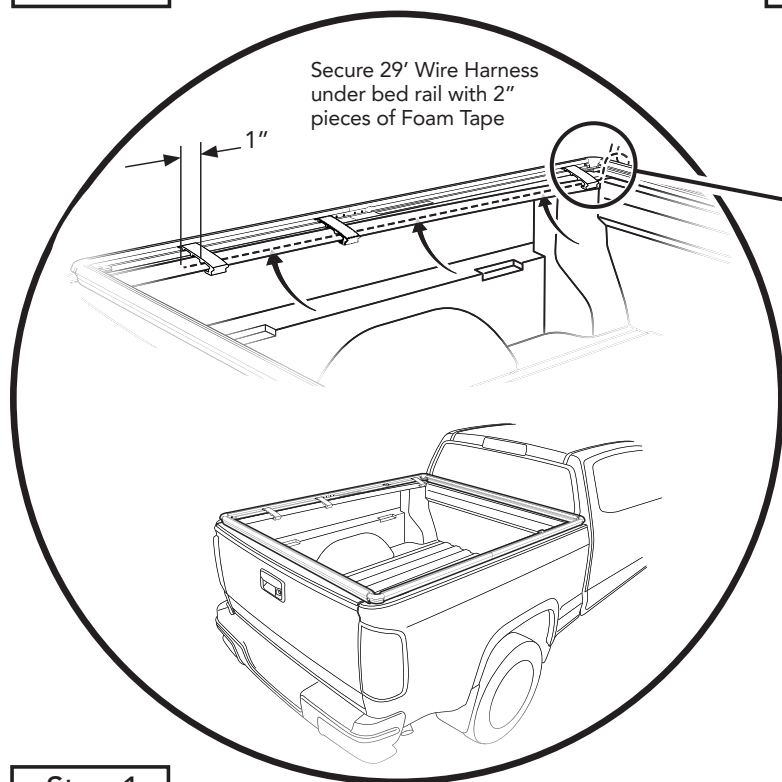

Detail

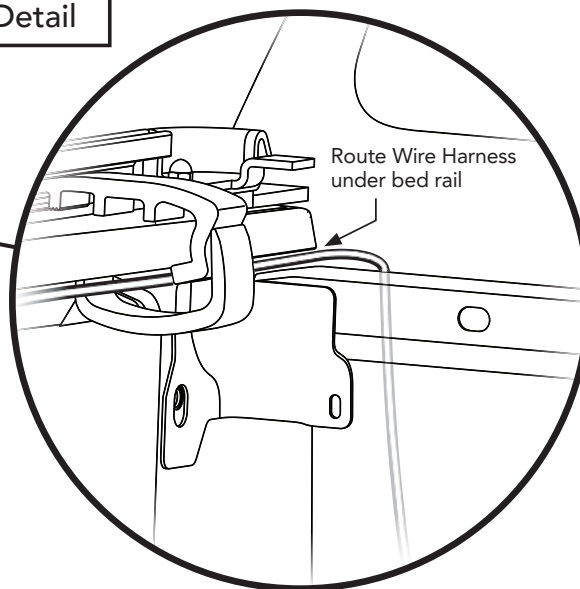

Hardware



Foam Tape
Part #595.31
2" Pieces

Step 1

Route the 29' Wire Harness from the front of the vehicle bed to the rear, underneath the bed rail, and through each of the three clamps. (See Detail) Attach the wire to the underside of the bed rail using 2" pieces of the Foam Tape #593.51. Run the wire to just 1" past the rear clamp.

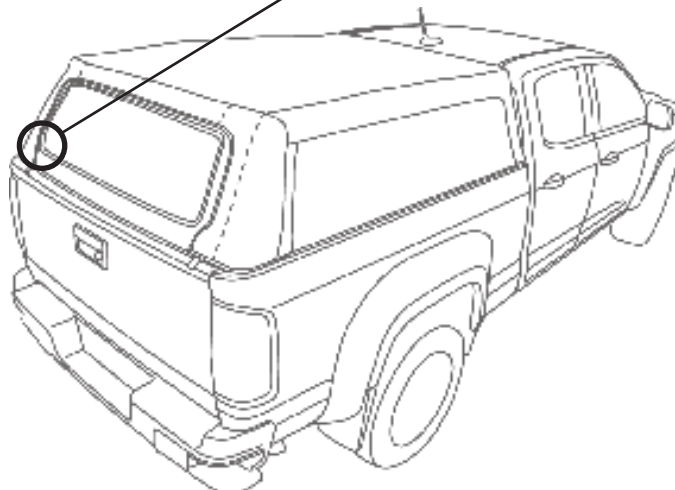

Step 2

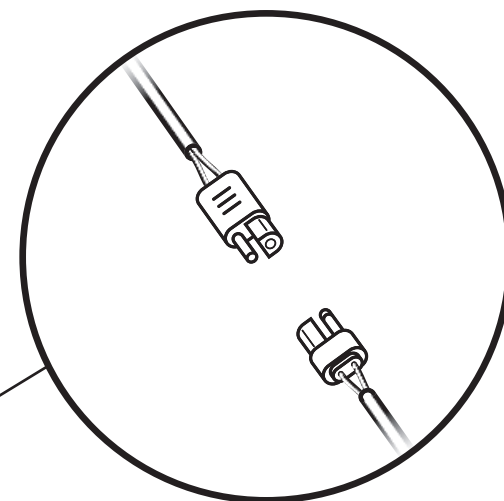

Step 2

routing the 29' Wire Harness, plug the 2-conductor connectors at the ends of the CHMSL Wire Harness and the 29' Wire Harness together.

NOTE: You must unplug these connectors before folding the top down.

Section 20 Opening and Storing the Top

Step 1

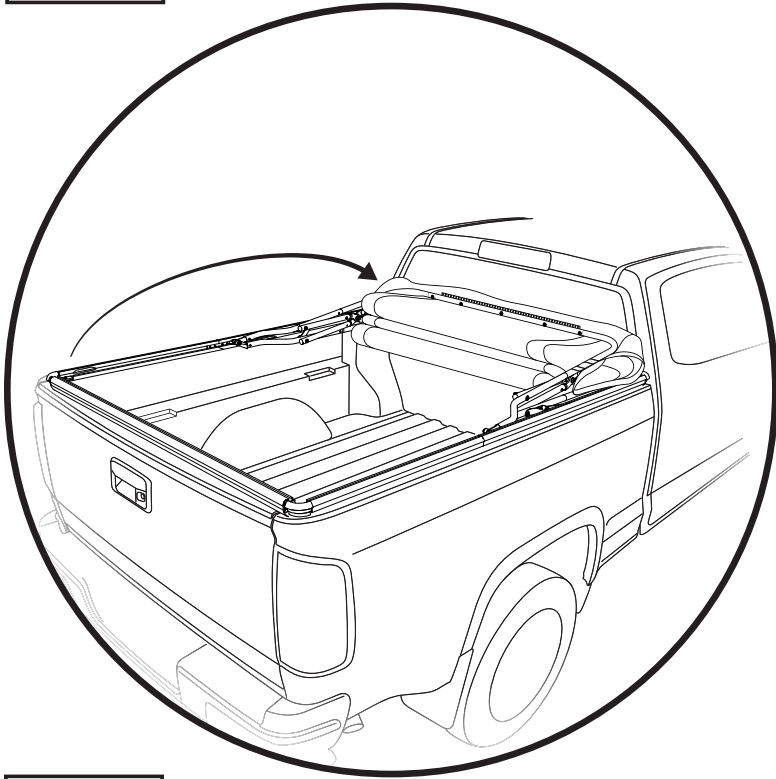

Step 1

To open the top:

- Unzip and remove Side Curtains.
- Unzip and remove Rear Window.
- Release plastic tabs from rails all around.
- Flip rear corners of top fabric up onto roof.
- Fold the top forward so that all the bows collapse and rest on the Front Rail.

Step 2

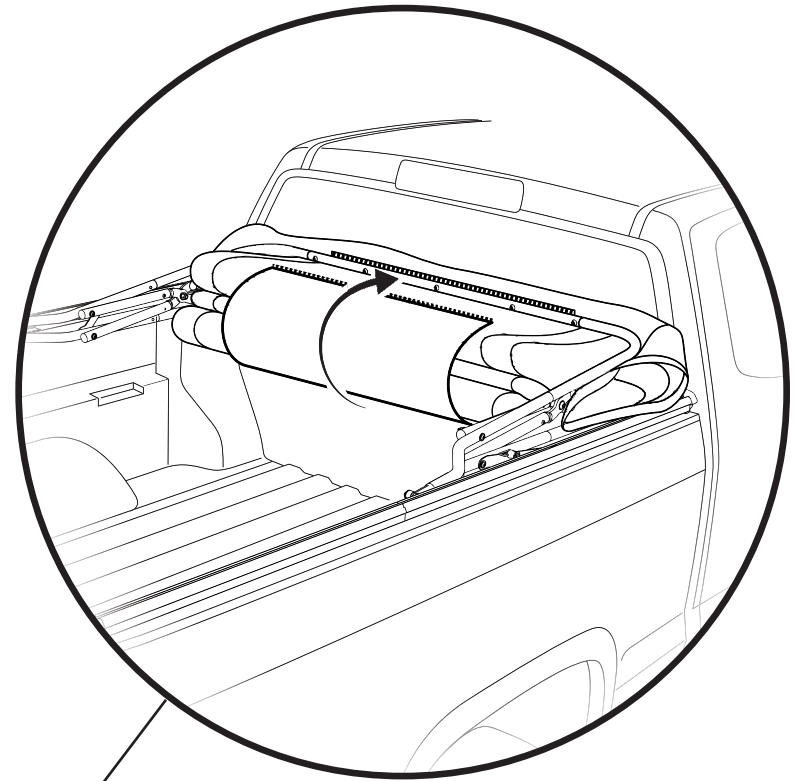

Step 2

Protect the top fabric by wrapping the Boot attached to the Front Window around the Fabric and Bows.

Secure the Boot by zipping it to the zipper for the Rear Window.

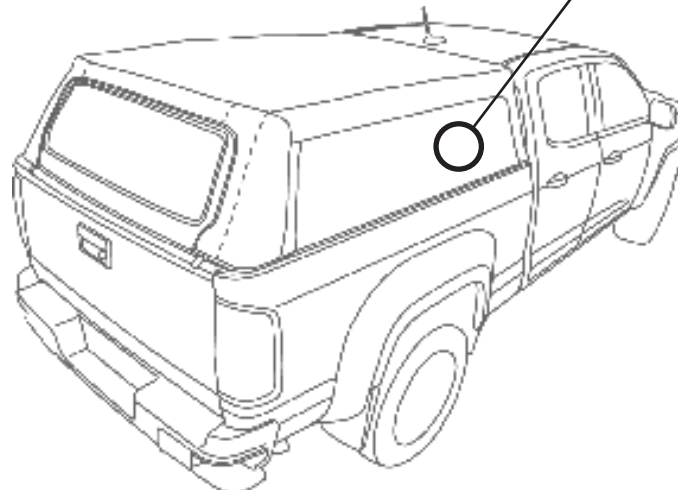

Section 21

Store Rear Rail When Top is Folded Down

Step 1

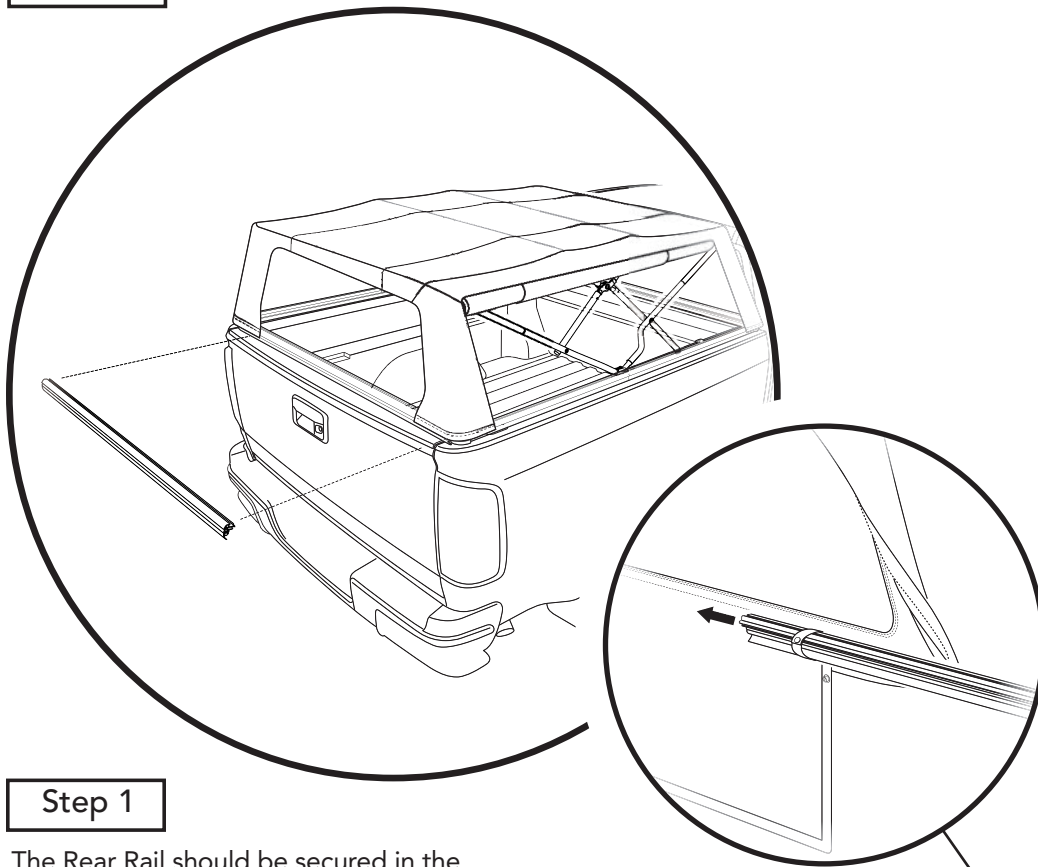

Step 1

The Rear Rail should be secured in the straps at the bottom of the Front Window when the top is folded down.

Wrap the straps around the Rear Rail and snap closed.

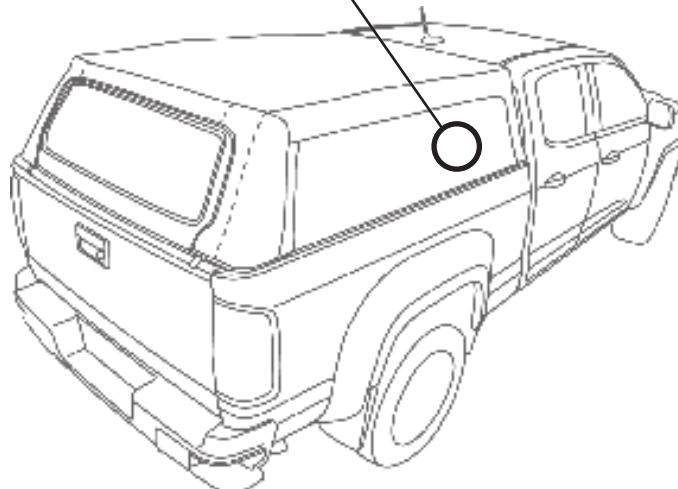

Step 1

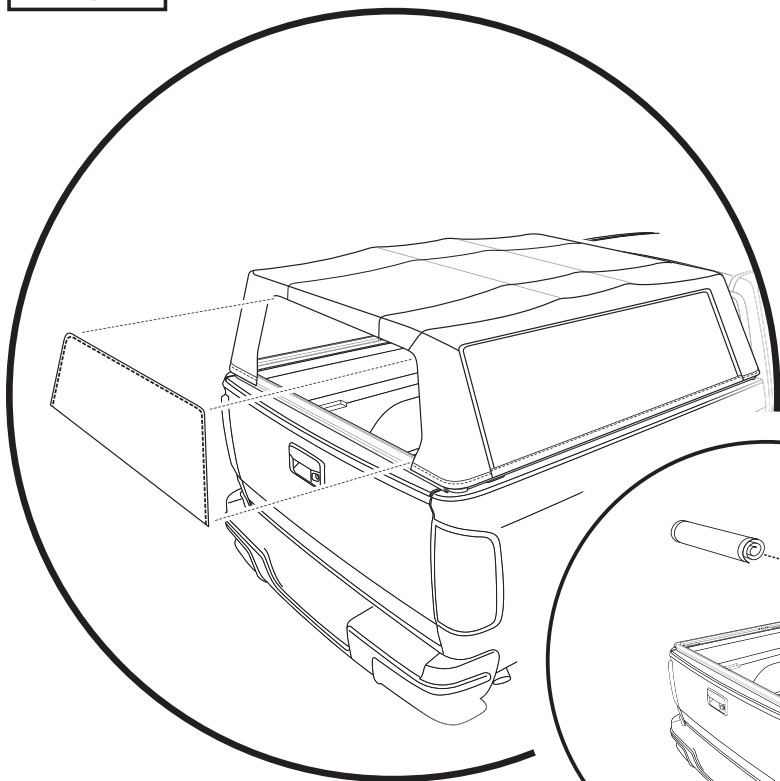

Step 1

With the Fabric Top up, the Rear Window can be stored in the Boot attached to the bottom of the Front Window.

Place the rolled-up Rear Window in the Boot, and zip the Boot closed.

Step 2

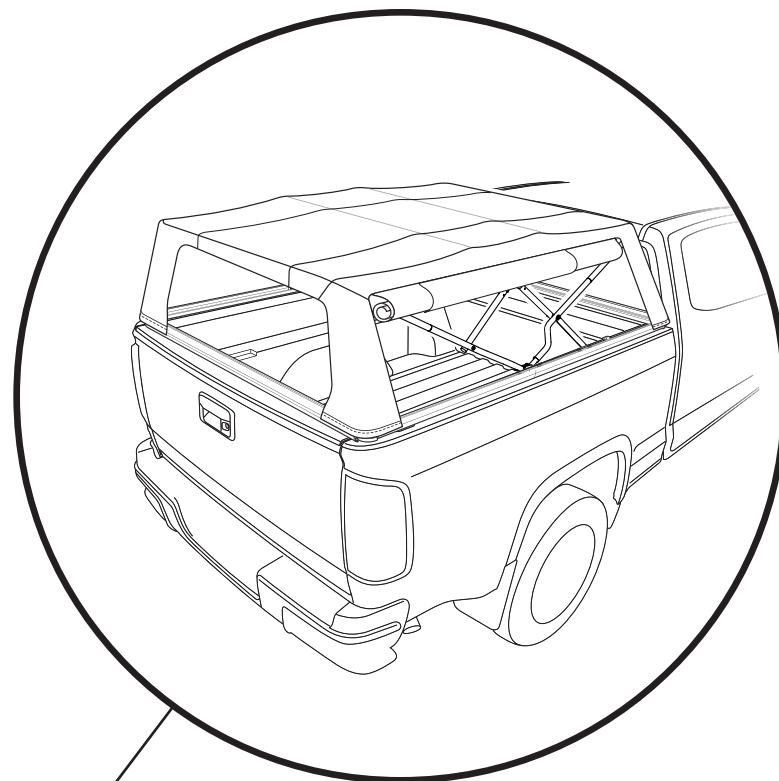

Step 2

With the Fabric Top up, the Side Curtains can be rolled up and secured with attached side flaps.

