



# Installation Instructions Supertop for Trucks

Vehicle Application:  
RAM - 5.7' BED 09-C  
Part Number 77327

## Installation Tips

Before you begin installing your new Supertop, please read all the instructions thoroughly.

It is recommended that two people install this Bestop product.

For a smooth fit:

For easier installation, the top should be installed at a temperature above 72° F. Below this temperature, the fabric may contract an inch or more, making it difficult to fit the vehicle. You may let the fabric sit in the sun for 15-20 minutes before installing to let the fabric warm up.

It is normal for the fabric to contract and wrinkle when stored in the shipping carton. Within a few days after installation, the fabric will relax and the wrinkles will disappear.



### WARNING

Do not rely in any way on the components of this product to protect against injury or death in the event of an accident. Never operate the vehicle in excess of manufacturer's specifications.









Read and follow, precisely, all installation instructions provided when installing this product. Failure to do so may result in a poor fit and could place occupants of the vehicle in a potentially dangerous situation.

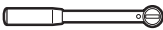

### CAUTION

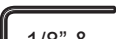
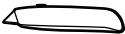
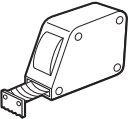
Safety glasses should be worn at all times when installing this product.

**WEAR SEAT BELTS AT ALL TIMES**

Tools			
 Ratchet	 9/16" Socket	- OR -	 9/16" Wrench
 Safety Glasses	 1/8" & 1/4" Allen Wrench	 Utility Knife	 Tape Measure
 Pliers	 Wire Ties (Not included)	 Phillips Screwdriver	

Installation Time
 2 hours
Skill Level
<div style="display: flex; justify-content: space-around; align-items: center;"> <div style="border: 1px solid black; border-radius: 50%; width: 30px; height: 30px; display: flex; align-items: center; justify-content: center;">1</div> <div style="border: 1px solid black; border-radius: 50%; width: 30px; height: 30px; display: flex; align-items: center; justify-content: center;">2</div> <div style="border: 2px solid black; border-radius: 50%; width: 30px; height: 30px; display: flex; align-items: center; justify-content: center;">3</div> <div style="border: 1px solid black; border-radius: 50%; width: 30px; height: 30px; display: flex; align-items: center; justify-content: center;">4</div> </div> <p>3 - Moderately Difficult</p>





# Installation Instructions Supertop for Trucks

Vehicle Application:  
RAM - 5.7' Bed 09-C  
Part Number 77327

## Parts List

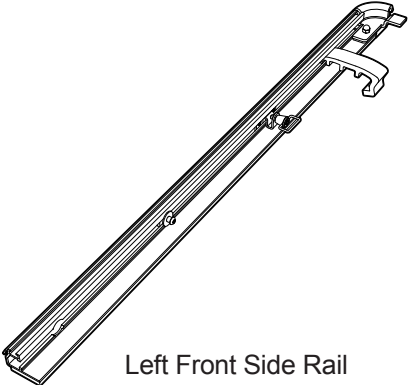
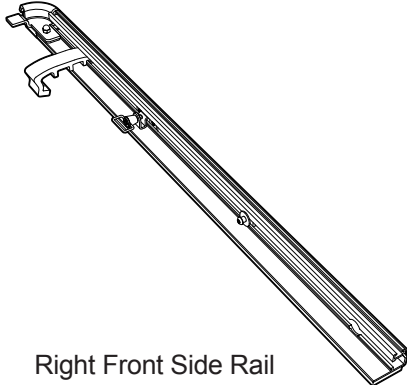
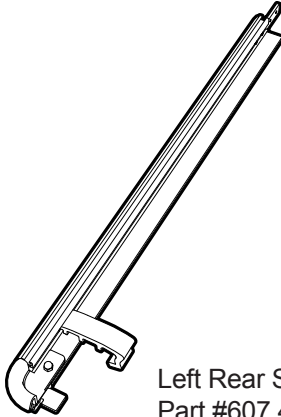
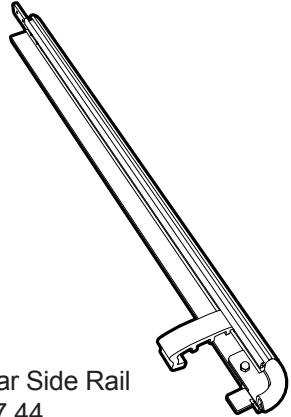
- Required parts for installation - Page number in Installation Guide

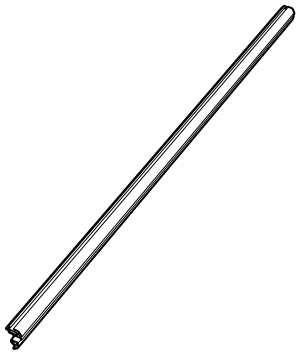
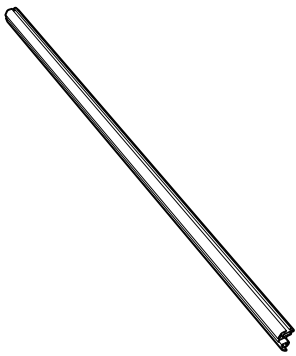
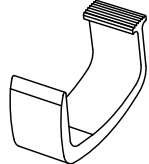
Sections 1 & 2		Side Rails		Pages 5 to 7 of Guide	
					
Left Front Side Rail Part #607.39 Qty. 1	Right Front Side Rail Part #607.38 Qty. 1	Left Rear Side Rail Part #607.45 Qty. 1	Right Rear Side Rail Part #607.44 Qty. 1		

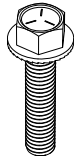
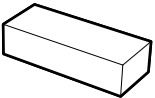
Sections 2 to 4		Hardware, Front and Rear Rails		Pages 6 to 9 of Guide	
					
Front Rail Part #606.76 Qty. 1	Rear Rail Part #584.95 Qty. 1	Lower Clamp Part #579.23 Qty. 4	Set Screw Part #573.17 Qty. 4	Hex Head Bolt Part #578.39 Qty. 4	Rubber Pad Part #720035 Qty. 8
		Wire Ó tt Connector Part #111EH Qty. 6			Module, Logic 3rd Brake Light Part #190.34 Qty. 1







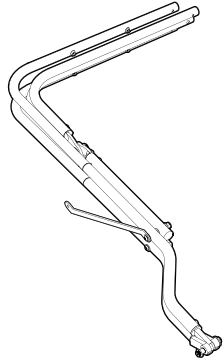
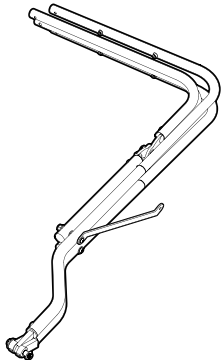
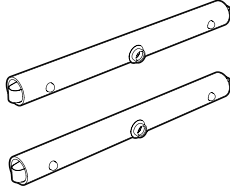
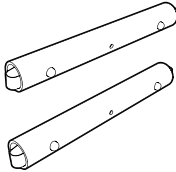

# Installation Instructions Supertop for Trucks

Vehicle Application:  
RAM - 5.7' Bed 09-C  
Part Number 77327

## Parts List

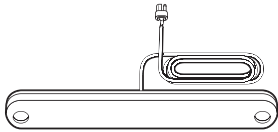
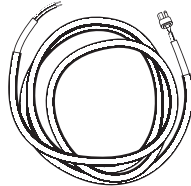
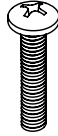
- Required parts for installation - Page number in Installation Guide

Sections 5 to 15		Bow Stacks, Bow Couplers, Wire Connectors			Pages 10 to 21 of Guide
					
Bow Stack - Driver Side Part #601.83 Qty.1	Bow Stack - Passenger Side Part #601.82 Qty.1	Bow Coupler #1 & #4 Bows Part #573.77 Qty. 2	Bow Coupler #2 & #3 Bows Part #573.79 Qty. 2	Wire Tap Part #577.58 Qty. 2	

Sections 12 to 16	CHMSL; Wire Harness; Top, Window, Side Curtains	Pages 12 to 25 of Guide
 <p>Center High-Mount Stop Light (CHMSL) Qty. 1</p>  <p>29' Wire Harness Qty. 1</p>  <p>#10-32 Screw Qty. 2</p>  <p>Flat Washer Qty. 2</p>  <p>#10-32 Nut Qty. 2</p> <p><b>Parts Kit #576.71</b></p>	 <p>Fabric Top</p> <p>Right Side Curtain (removed)</p> <p>Left Side Curtain</p> <p>Rear Window</p>	

# Section 1

## Assemble Side Rails; Remove Paper Backing from Foam Tape

Step 1

Hardware

Step 2

573.17

607.39

607.38

607.45

607.44

 Set Screw  
Part #573.17  
Qty. 4

Front Side Rail  
Part #607.39 - Left (shown)  
Part #607.38 - Right  
Qty. 1 of each

Rear Side Rail  
Part #607.45 - Left (shown)  
Part #607.44 - Right  
Qty. 1 of each

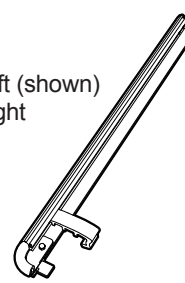
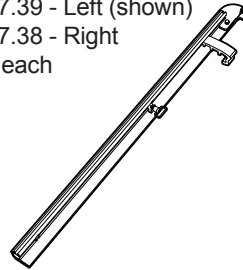

Tools



1/8" Allen  
Wrench

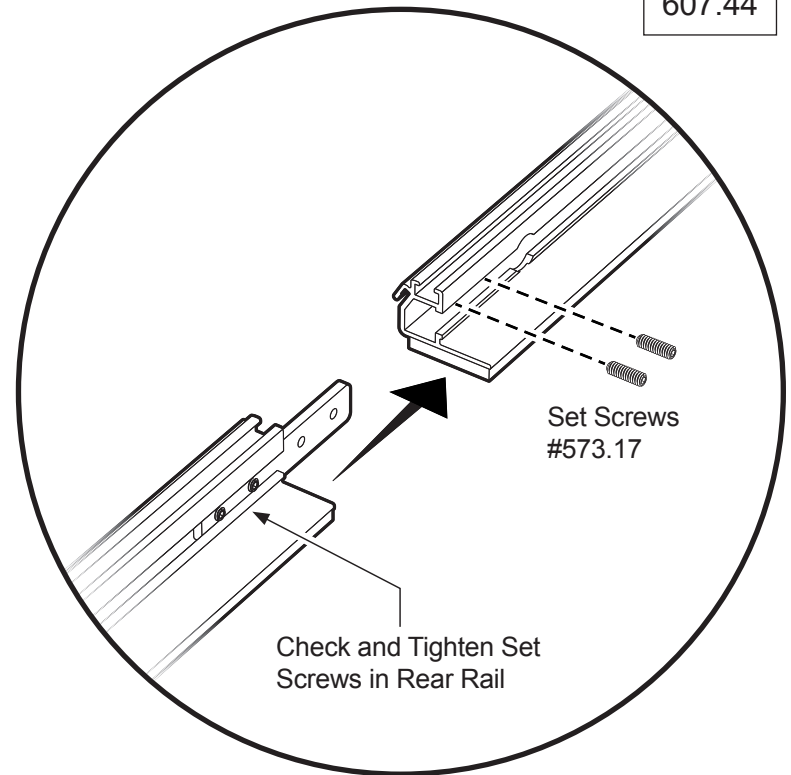
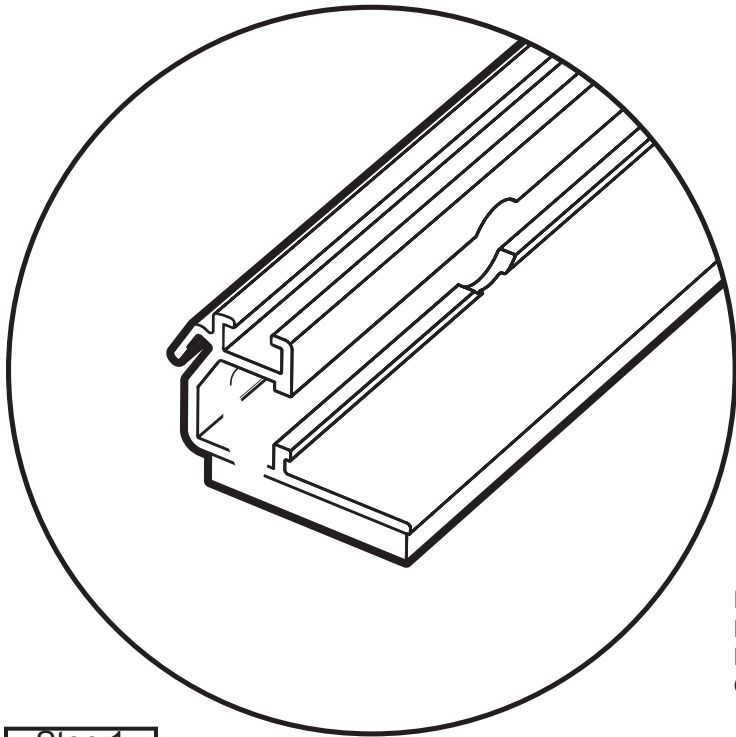

Step 1

Locate the Foam Tape on the Left and Right Side Rails, and remove the paper backing from the foam tape.

Repeat with the both Side Rails.

Step 2

Assemble the Left Front Side Rail #607.39 and the Left Rear Side Rail #607.45.

Slide the rails together, and secure using two set screws #573.17.

Check and tighten the two (2) set screws in the rear rail.

Repeat with the Right Side Rails.

## Section 2 Attach Front & Rear Rails; Attach Side Rail Assemblies

Step 1 606.76 584.95

Hardware

Step 2 Side Rail Assemblies

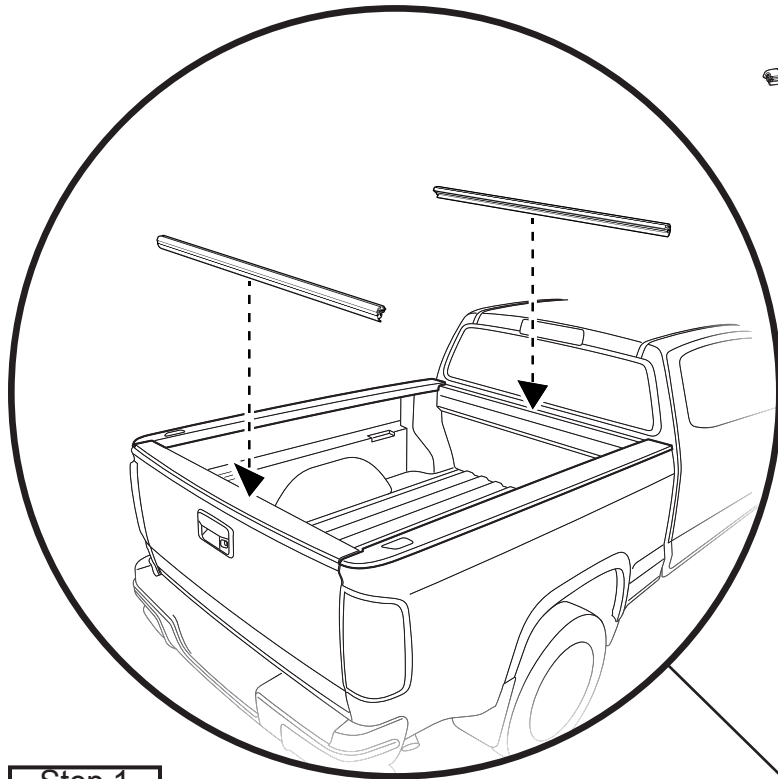

Side Rail Assemblies  
Qty. 1 of each

Front Rail  
Part #606.76  
Qty. 1

Rear Rail  
Part #584.95  
Qty. 1

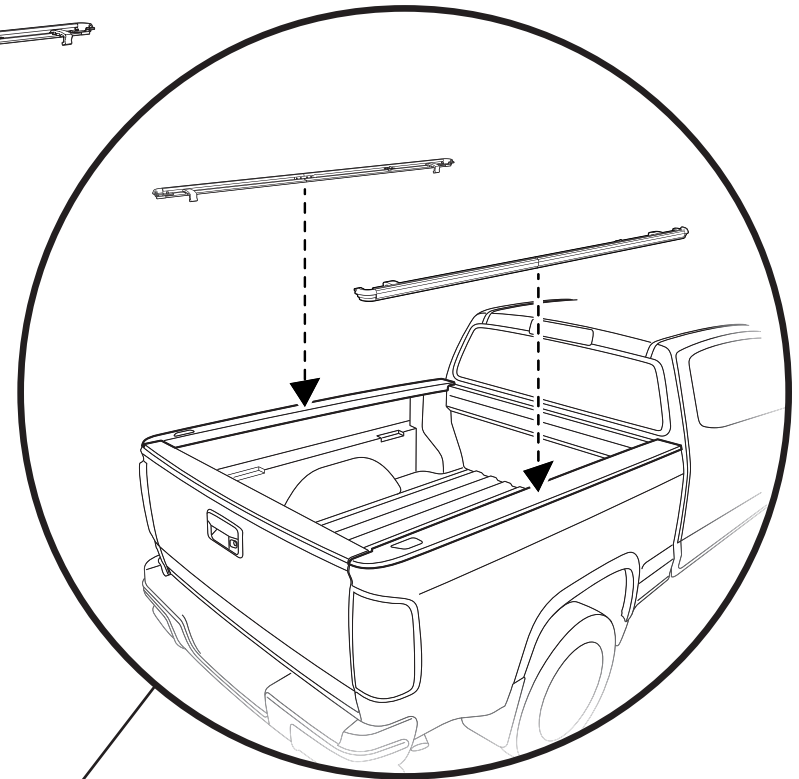

### Step 1

Place the Front Rail #606.76 and Rear Rail #584.95 onto the truck bed.

Lay the Rails on top of the truck bed in front, and on top of the plastic bed protector at the rear.

**NOTE:** The Front Rail is longer than the Rear Rail.

### Step 2

Place Side Rail assemblies onto the truck bed. Lay the Rails on top of the plastic bed protectors.

Attach the Side Rails to the Front and Rear Rails.

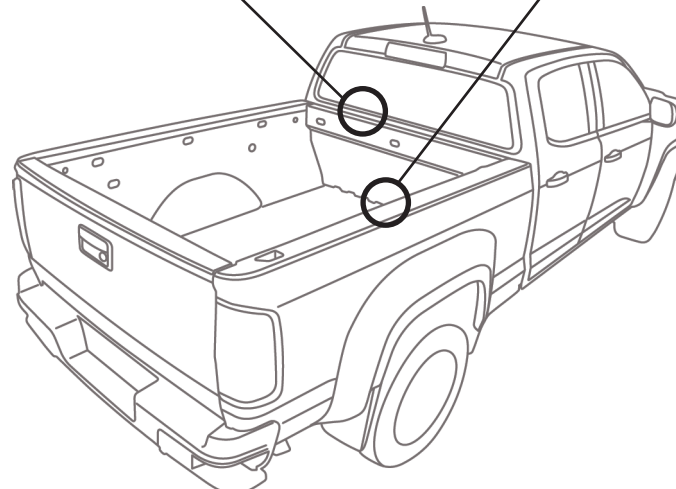

## Section 2 Attach Front & Rear Rails; Attach Side Rail Assemblies (cont.)

### Step 1

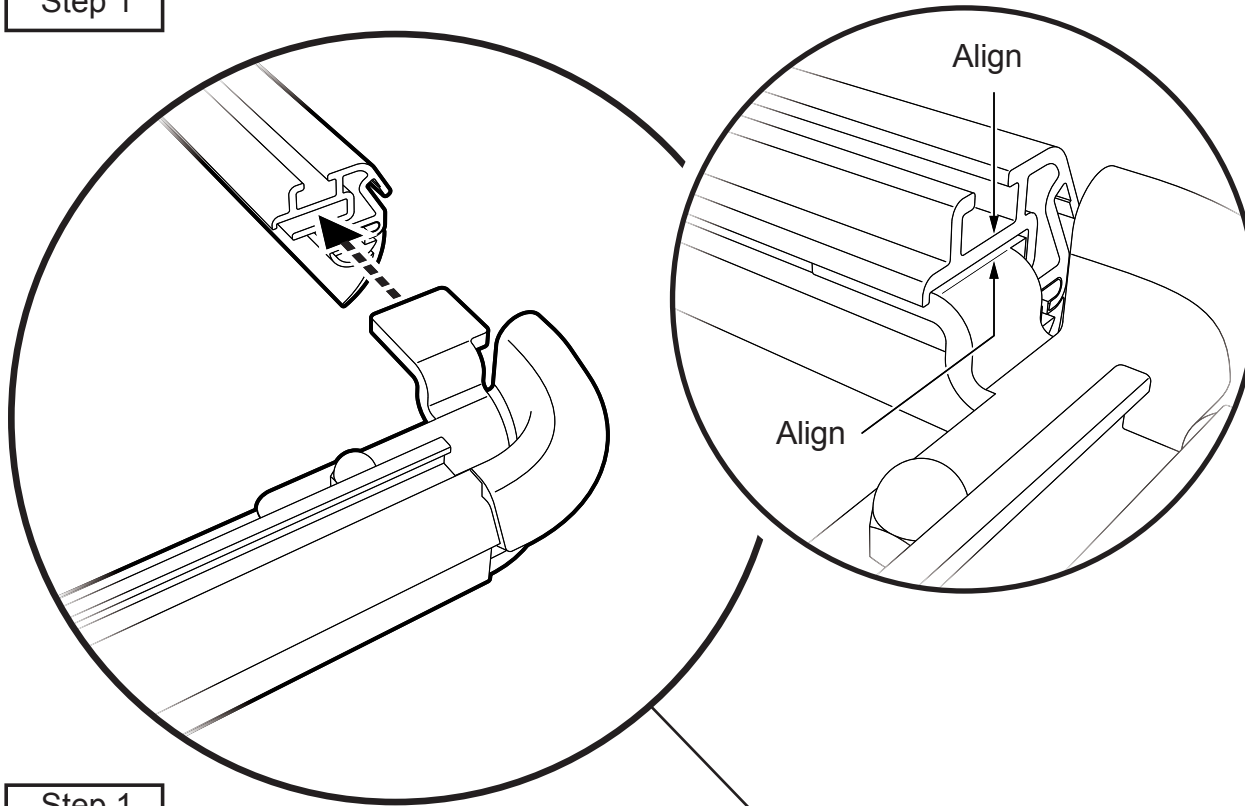

### Step 1

Attach the Front and Rear Rails to the Side Rail Assemblies.

Slide the tabs at the front and rear of the Side Rail Assemblies into the slots in the Front and Rear Rails.

Make sure that the ends of the Front Rail and Rear Rail extrusions are aligned with the tongue of the attachment feature, where the tongue bends, and the small corner protrudes.

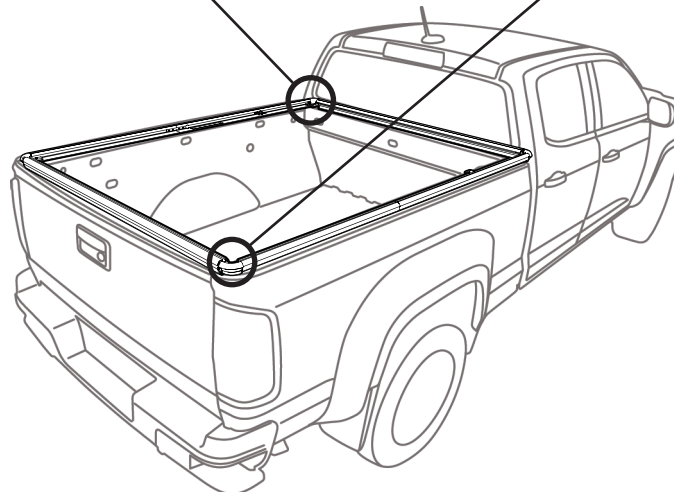

### Step 2

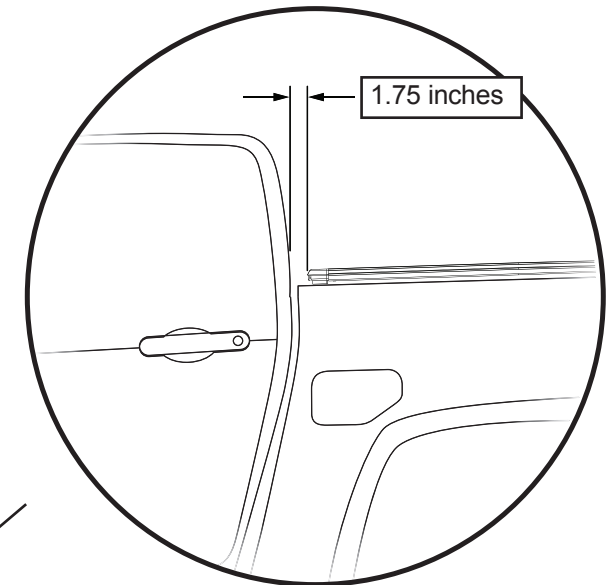

### Step 2

Place the outer edge of both side rail corners 1.75 inches from the back of the vehicle cab.

## Section 3 Adjust Rails; Install Rubber Pads

### Step 1 Rail Assembly



#### Step 1

Adjust the Side and Front and Rear Rail assembly right-to-left to center it on the bed width.

### Hardware

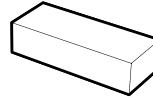

Rubber Pad  
Part #720035  
Qty. 4

### Step 2 720035

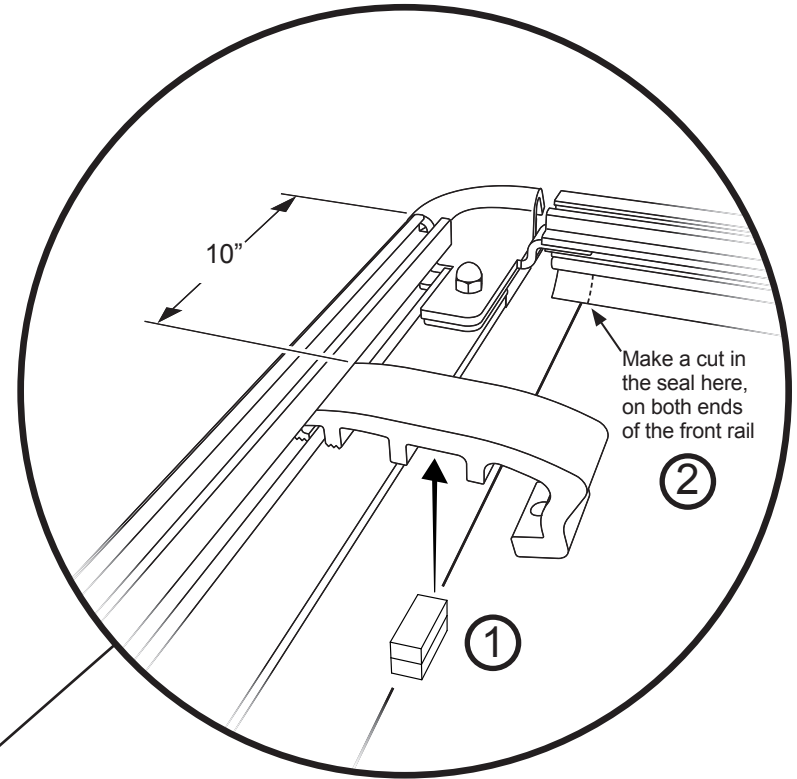

#### Step 2

① Attach two (2) Rubber Pads #720035 together, and stick them to the Front Rail Clamp, between the rib farthest from the rail, and the next rib.

The rubber pads must rest on top of the bed rail cap after installation.

Front Clamp should be located 10" from the end of the Front Side Rail.

② Make two cuts in the seal on the bottom of the front rail, in line with the inner edge of the bed rail cap, so that the seal will lay flat against the bed bulkhead.

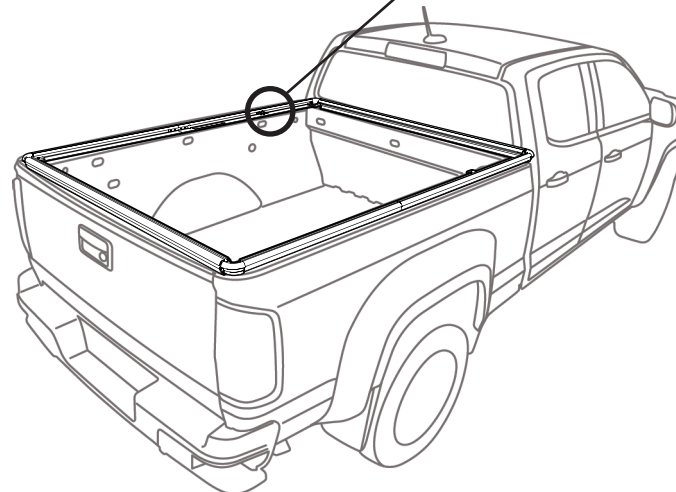

## Section 4 Install Rubber Pads; Attach Lower Clamps

Step 1 720035

Hardware

Step 2 579.23 578.39

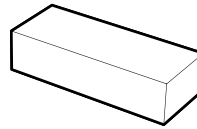
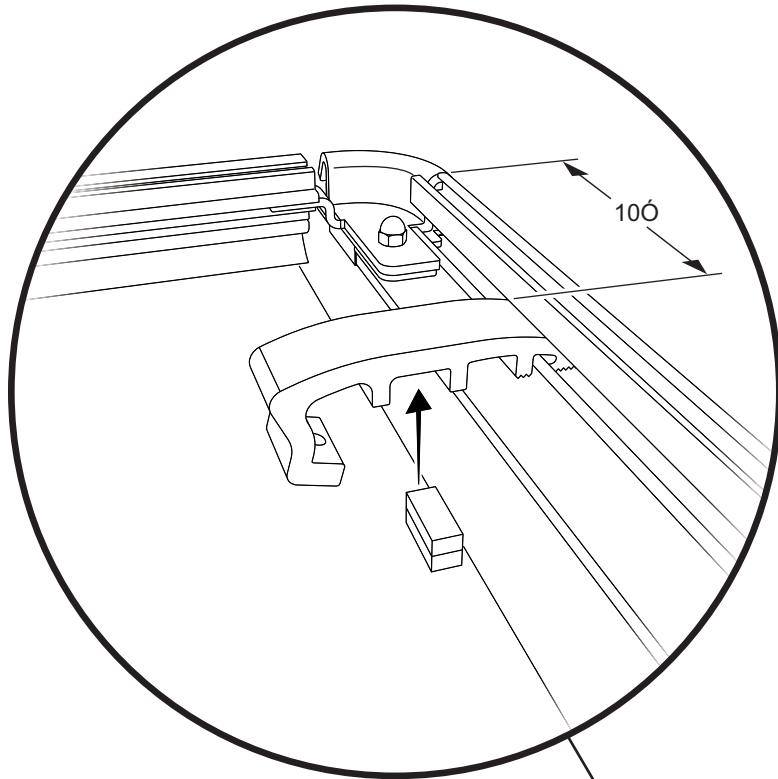

Rubber Pad  
Part #720035  
Qty. 4

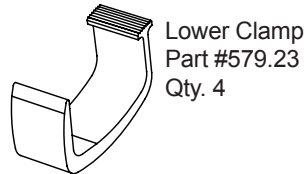

Lower Clamp  
Part #579.23  
Qty. 4

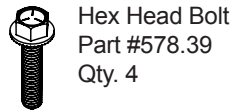

Hex Head Bolt  
Part #578.39  
Qty. 4

**NOTE: IF YOU HAVE THE UTILI-TRAC, SKIP STEP 2 AND GO TO PAGE'S 10 & 11.**

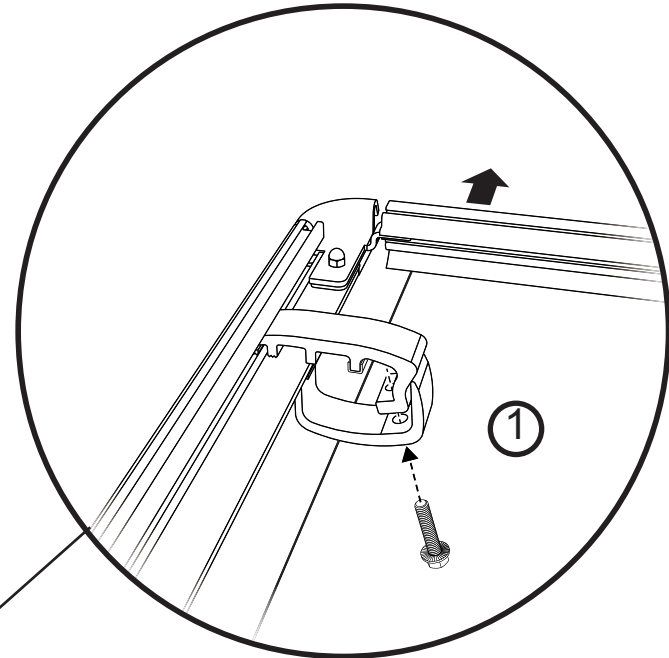

### Step 1

Attach two (2) Rubber Pads #720035 together, and stick them to the Rear Rail Clamp, between the rib farthest from the rail, and the next rib.

The rubber pads must rest on top of the bed rail cap after installation.

Rear Clamp should be located 10" from the end of the Rear Side Rail.

**NOTE:** Make sure that the Rubber Pads are lined up on top of the vehicle's bed rail cap.

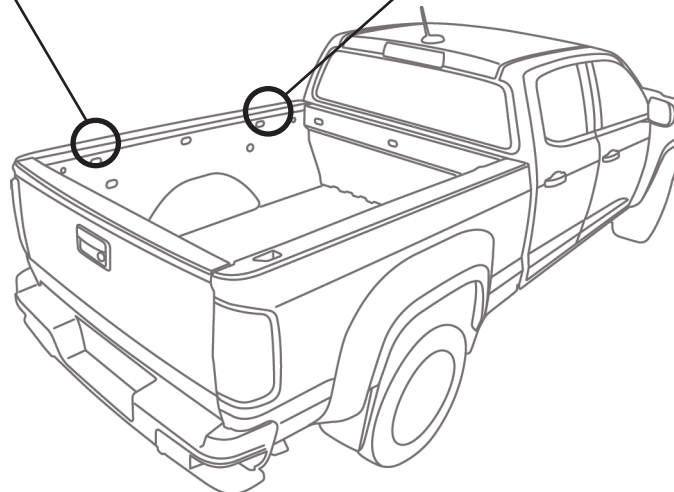

### Step 2

① Attach Lower Clamps #579.23 to the pre-assembled Upper Clamps on the Side Rails, using one (1) Hex Head Bolt #578.39 for each clamp.

Check alignment of the Rail Assembly and tighten all bolts.



## Section 5 Assemble Bows

Step 1 573.77 573.79 601.82

Hardware

601.82 601.83

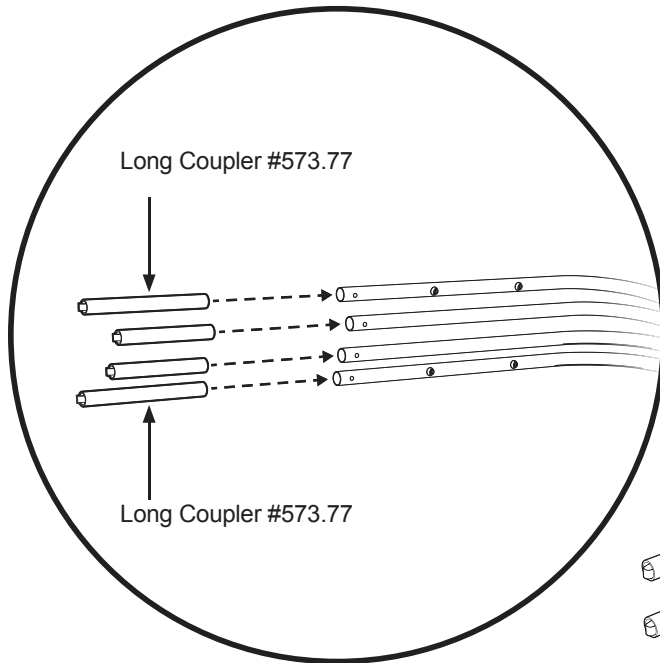

Bow Stack - Driver Side  
Part #601.83  
Qty.1

Bow Stack - Passenger Side  
Part #601.82  
Qty.1

Bow Coupler #1 & #4 Bows  
Part #573.77  
Qty. 2

Bow Coupler #2 & #3 Bows  
Part #573.79  
Qty. 2

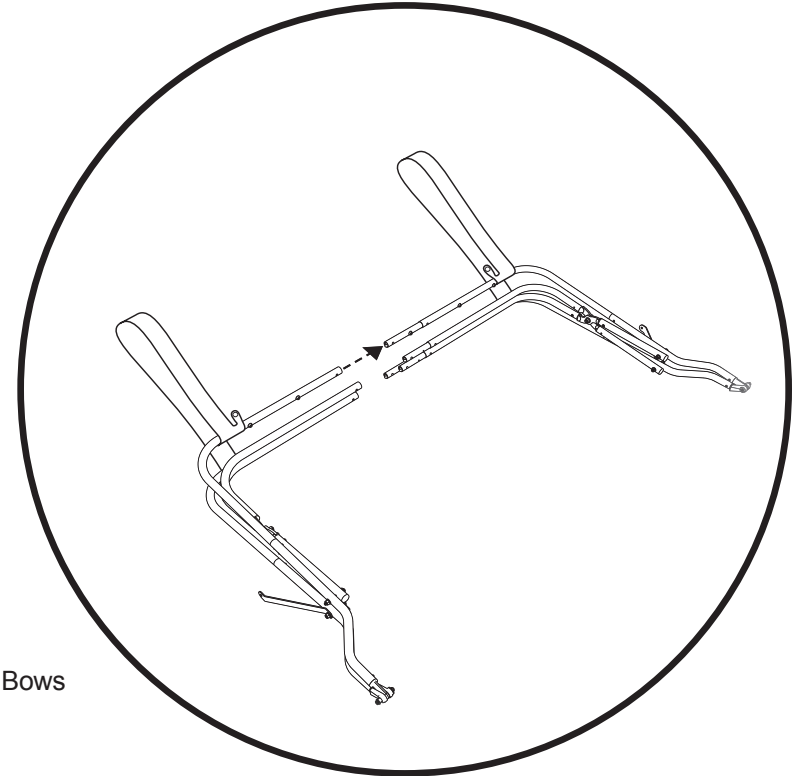

### Step 1

Attach Bow Couplers #573.77 and #573.79 to the Passenger Side Bow Stack #601.82.

Insert Long Couplers #573.77 into the outer bows #1 and #4.

Insert Short Couplers #573.79 into the inner bows #2 and #3.

#### For Easier Installation:

Slide all bows and couplers together before snapping the spring clips into the holes in the bows.

### Step 2

Attach Driver Side Bow Stack #601.83 to Passenger Side Bow Stack #601.82.

Bow Stacks attach using the Couplers installed in Step 1.

Slide the Couplers installed in the Passenger Side Bow Stack into the ends of the bows on the Drivers Side Bow Stack.

Before attaching couplers to bow stacks, make sure to pull the bond coat straps out and away from the bows, and lay them flat.

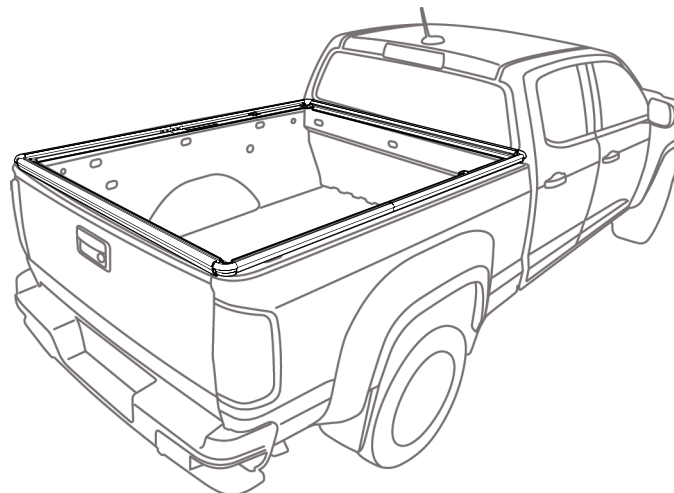

## Section 6 Install Bow Assembly

### Step 1 Bow Assembly

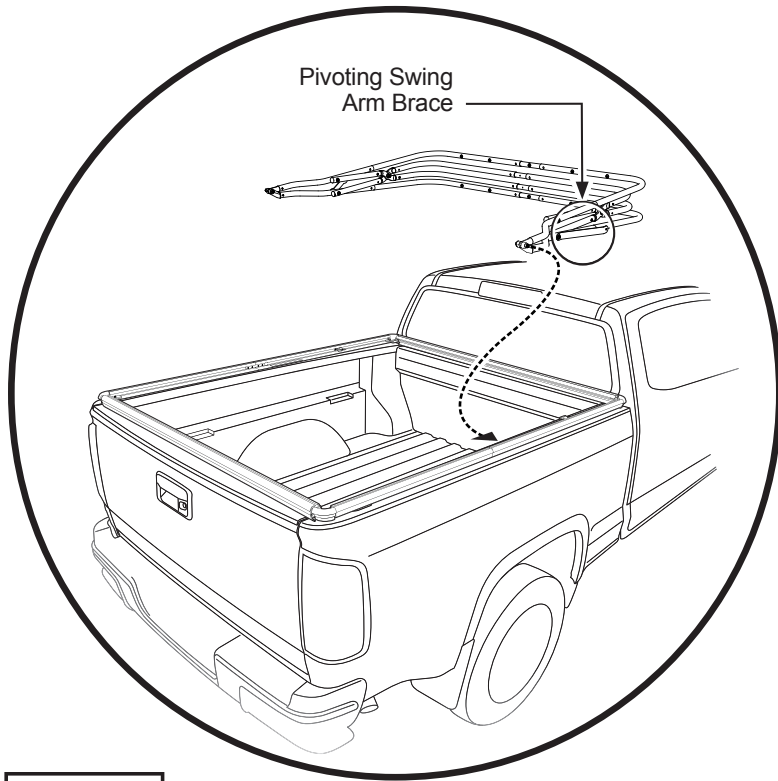

### Details

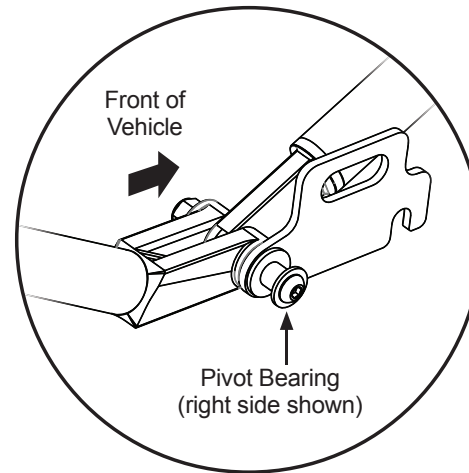

### Details

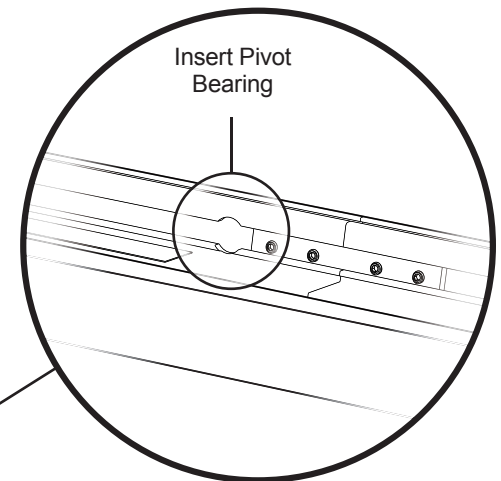

### Step 1

**NOTE:** Two People Are Required for This Portion of the Installation Process.

Place the folded Bow Assembly on the Side Rails. Make sure that the pivot swing arm braces are on the lowest bow.

Insert the Pivot Bearings into the receiving holes in the inside of the side rails

See Details.

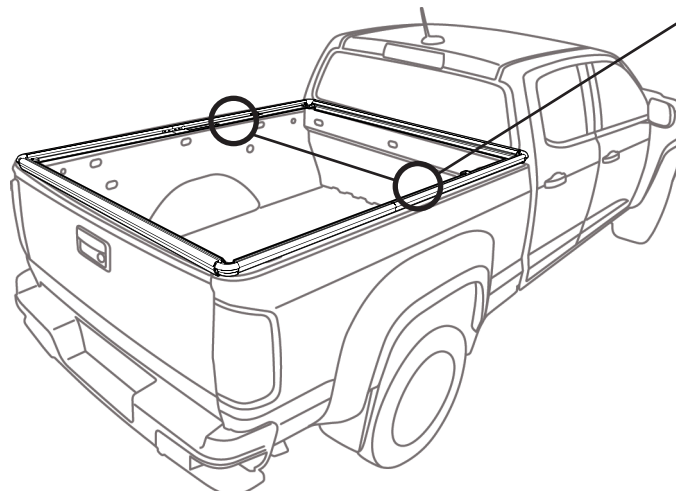

## Section 7 Unfold Bows; Attach Pivot Arm Braces; Engage Locking Levers

### Step 1

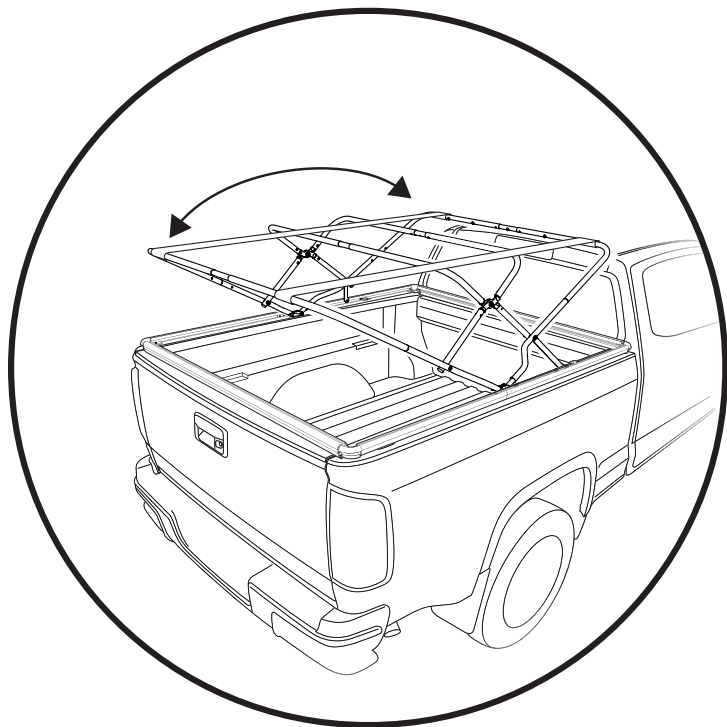

### Step 2

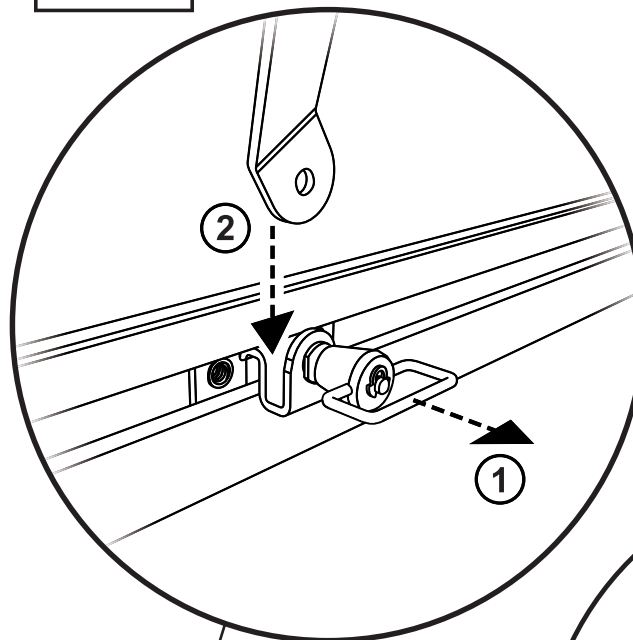

### Step 3

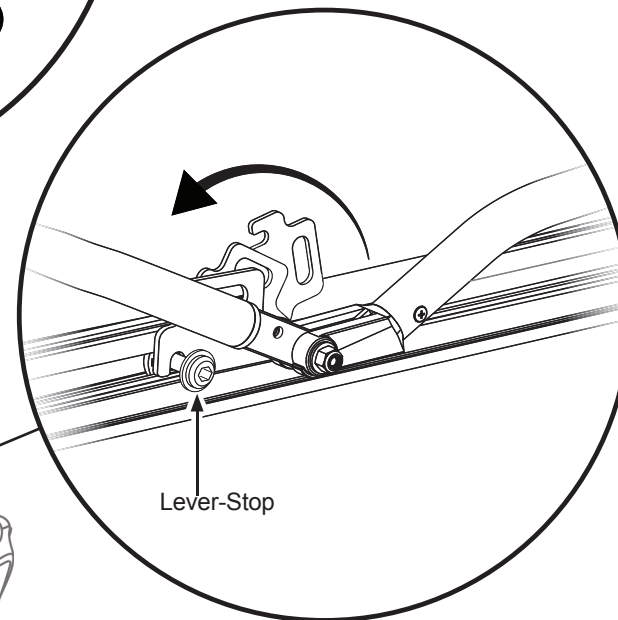

### Step 1

Unfold the Bow Assembly.

### Step 2

① Pull back on the Pivot Knuckle release knob;

② Snap the Pivot Arm Brace into place, on both sides of the truck.

### Step 3

Engage the Locking Lever on both sides of the truck.

**NOTE:** The Lever-Stop Assemblies are pre-installed at the factory at 26.87" from the front edge of each Side Rail.

**Section 8** Lay Folded Top Fabric on Bows; Unfold Top Fabric

**Step 1**

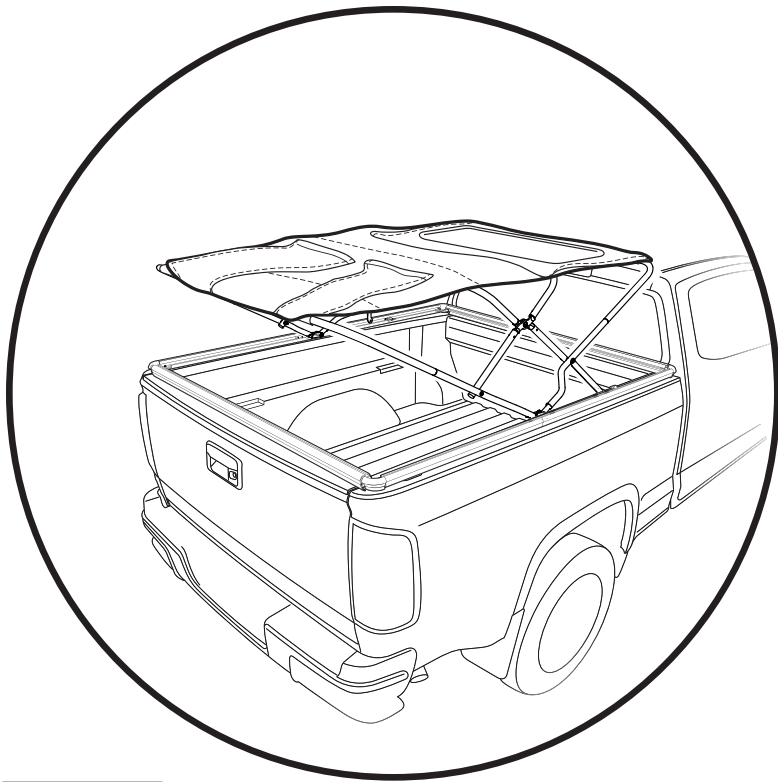

**Step 2**

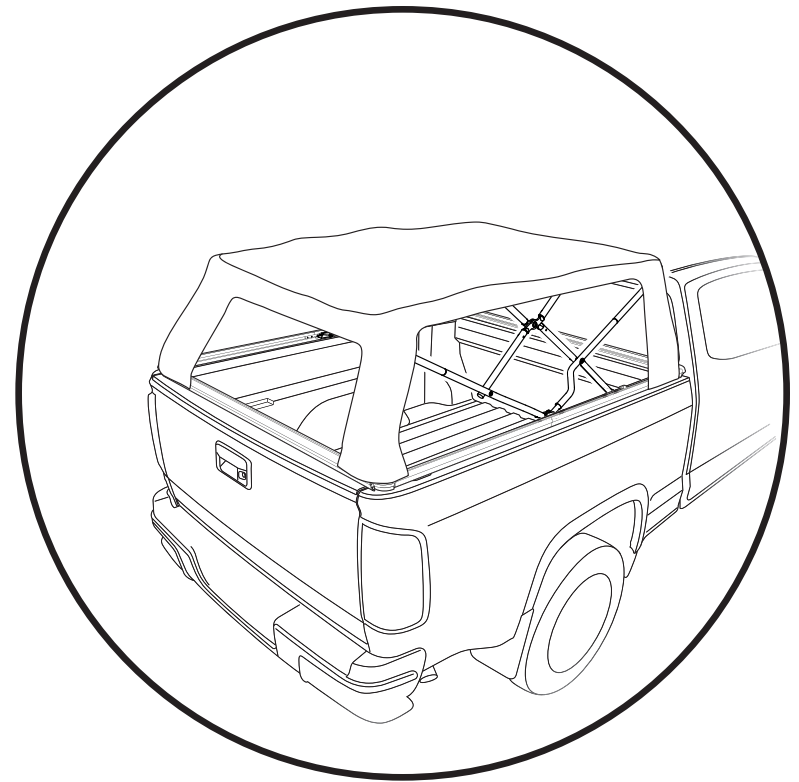

**Step 1**

Place the folded Soft Top onto the unfolded Bow Assembly.

**Step 2**

Unfold the front and back of the Top over the #1 and #4 Bows.

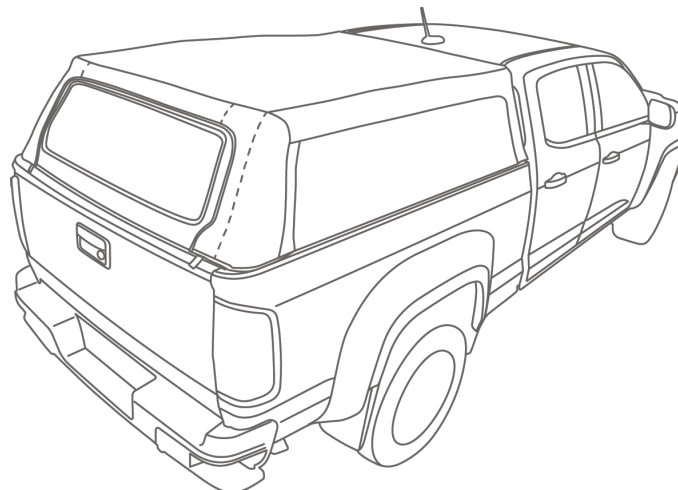

## Section 9 Secure Top Fabric to Bows

### Step 1

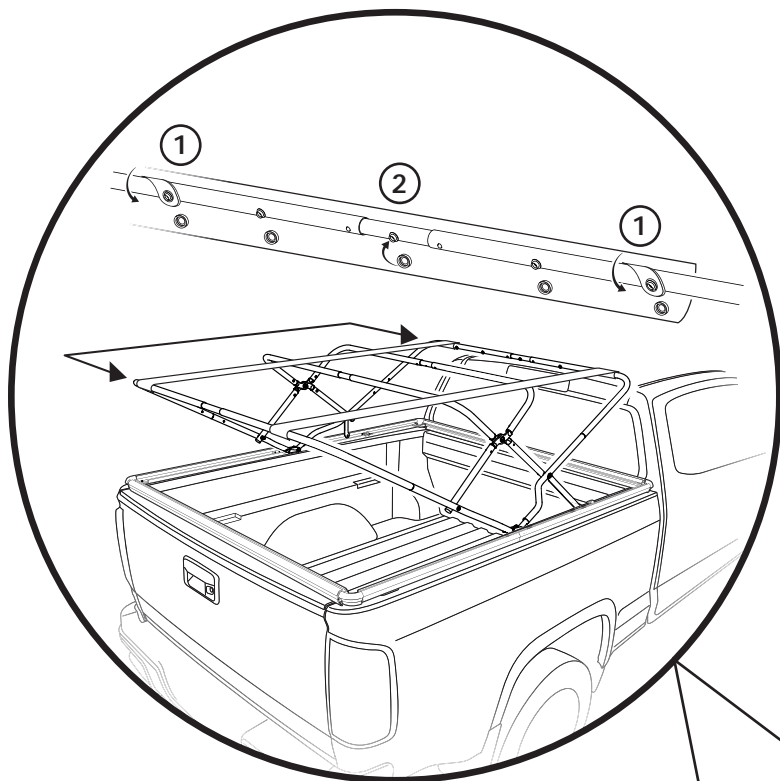

### Step 1

From inside the truck bed:

- ① Wrap the small flaps with holes over the outer-most snaps on the #1 bow (Bow closest to the truck cab).
- ② Wrap the fabric flap around the #1 Bow and snap all five snaps to secure the fabric to the Bow.

**NOTE:** Secure the outer snaps before securing the center snaps.

Repeat for the #4 Bow (Bow closest to the truck tailgate).

### Step 2

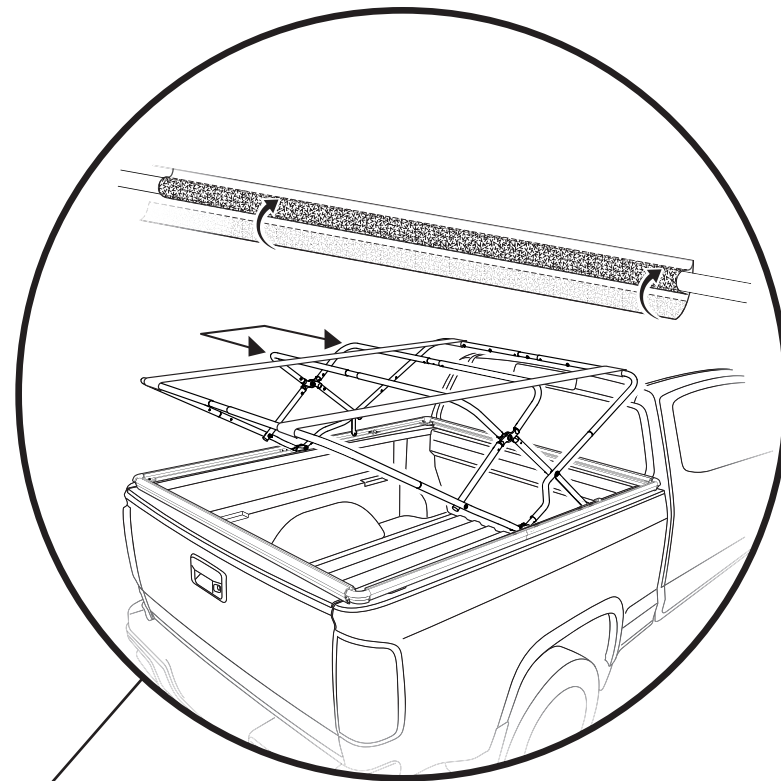

### Step 2

From inside the truck bed:

Wrap the fabric flaps with hook-and-loop around the #2 and #3 bows (the two middle bows) to secure the top fabric to these Bows.

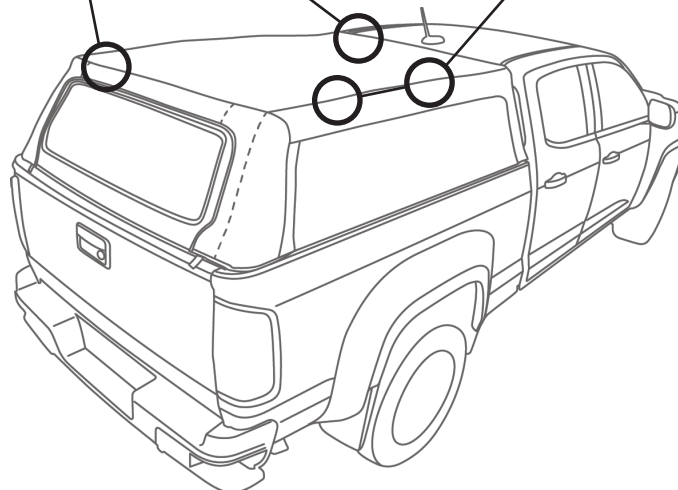

## Section 10 Slide Front Rail into Front Window

Step 1

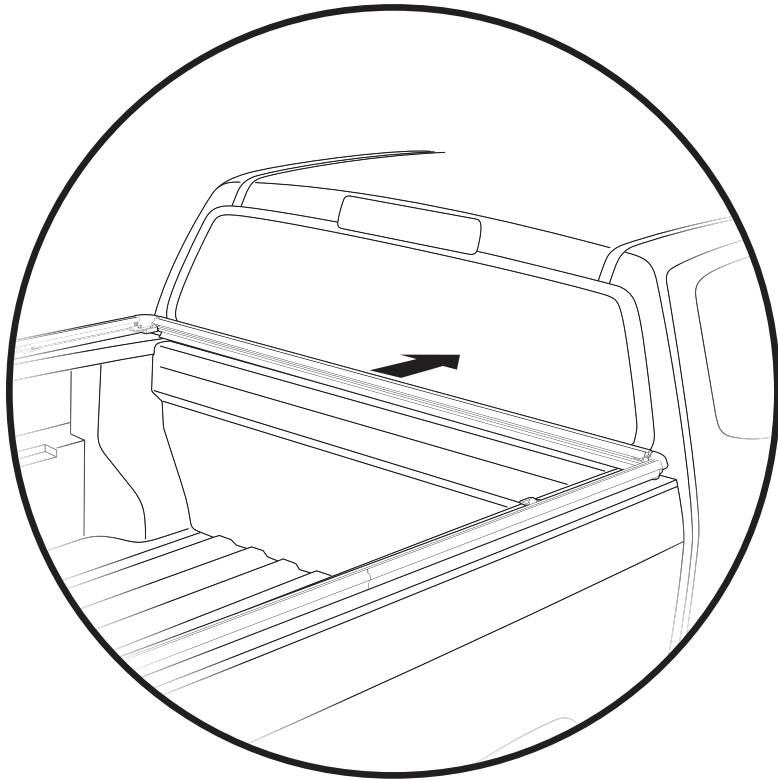

Step 1

Remove the front rail, by sliding it toward the front of the truck bed.

Step 2

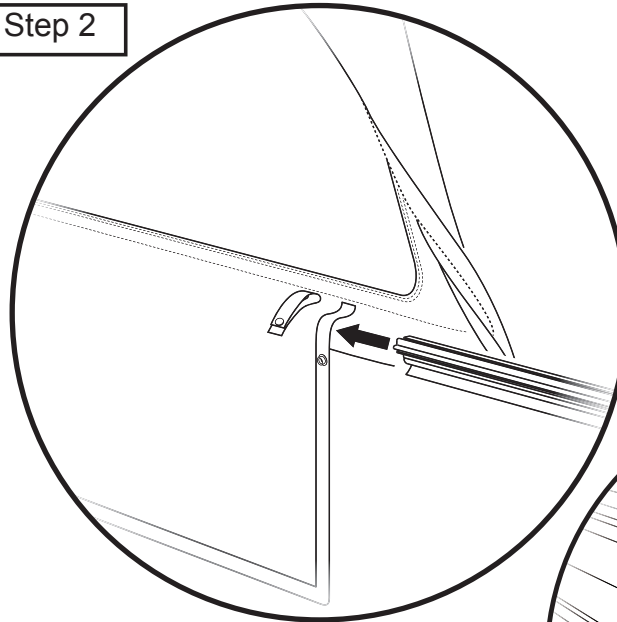

Detail

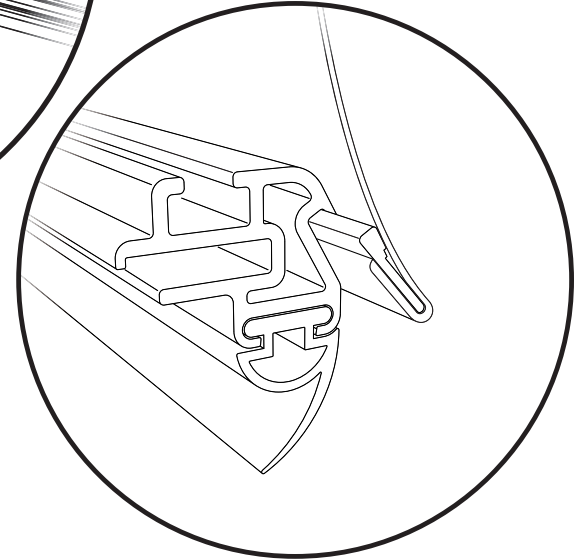

Step 2

Slide the front rail onto the plastic retainer at the bottom of the front window. The rail should go under the large flap.

See Detail.

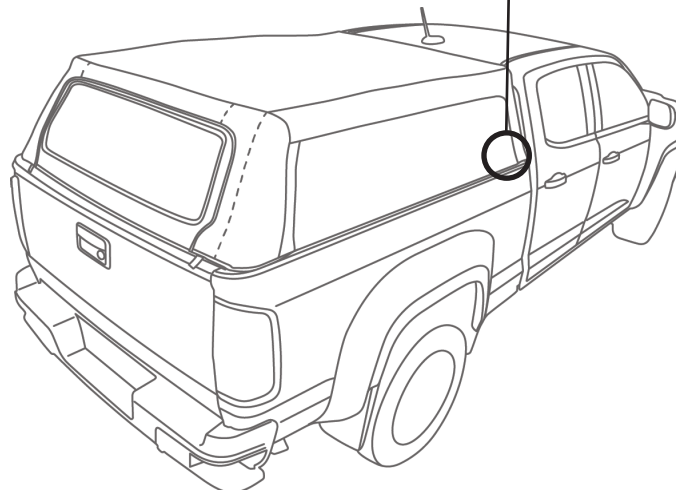

## Section 11 Tuck Plastic Tabs into Rails

Step 1

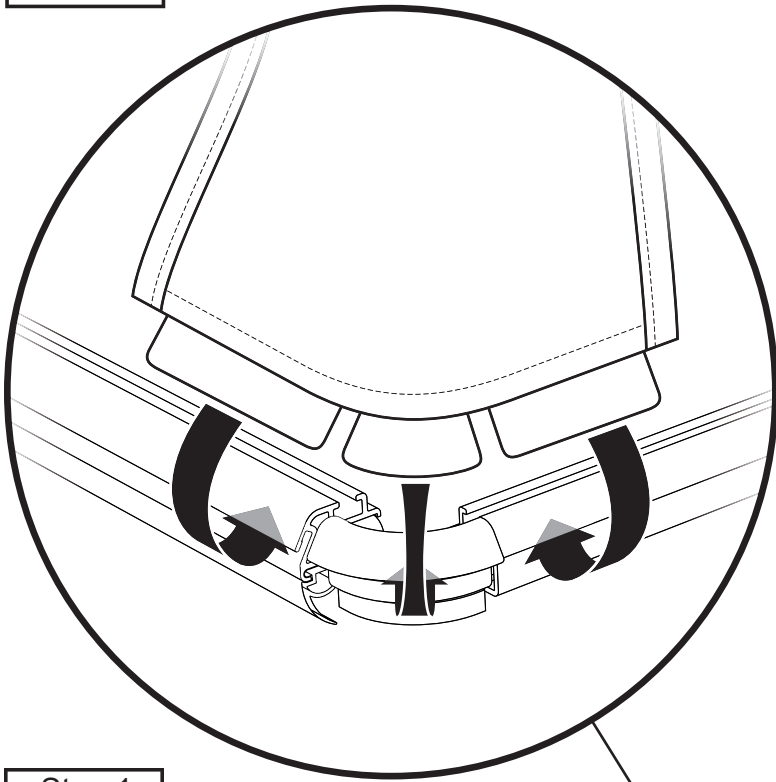

Step 1

Tuck the plastic tabs at the bottom of each corner of the top into the slots in the Side Rails and Front and Rear Rails.

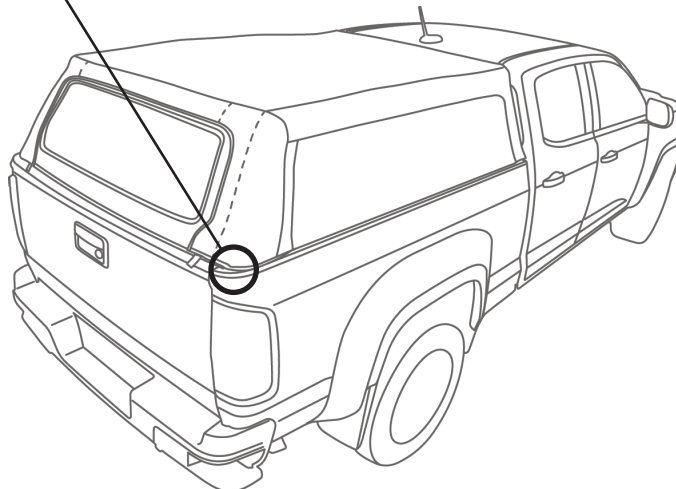

## Section 12 Tighten Adjustment Screws; Install Side Curtains

Step 1

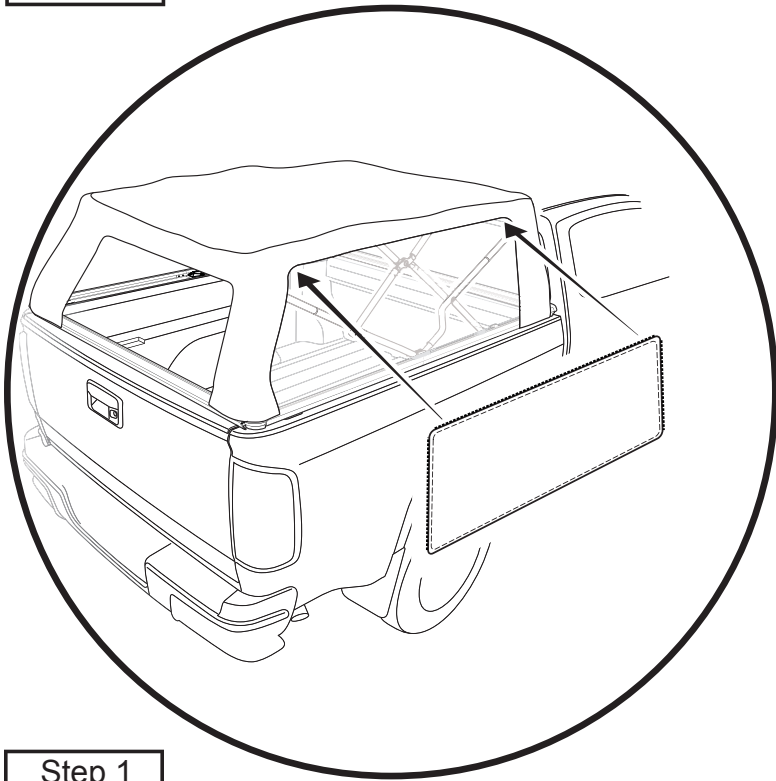

Step 1

For easier access to the zippers, you may want to lift the corners of the top onto the roof fabric.

Zip the Rear Window and Side Curtains into place.

Start with the zipper along the top edge of each panel, and then follow with the side zippers. For ease of installation, start each zipper only about 6".

Once all zippers are started, flip the rear corners into the rail, then zip all zippers completely shut.

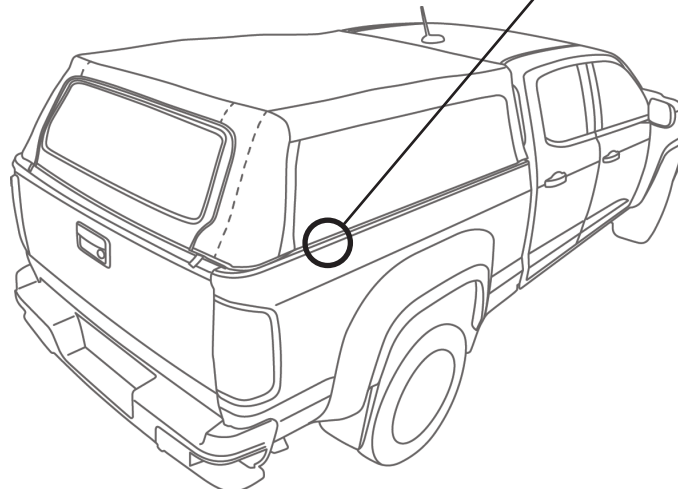

Step 2

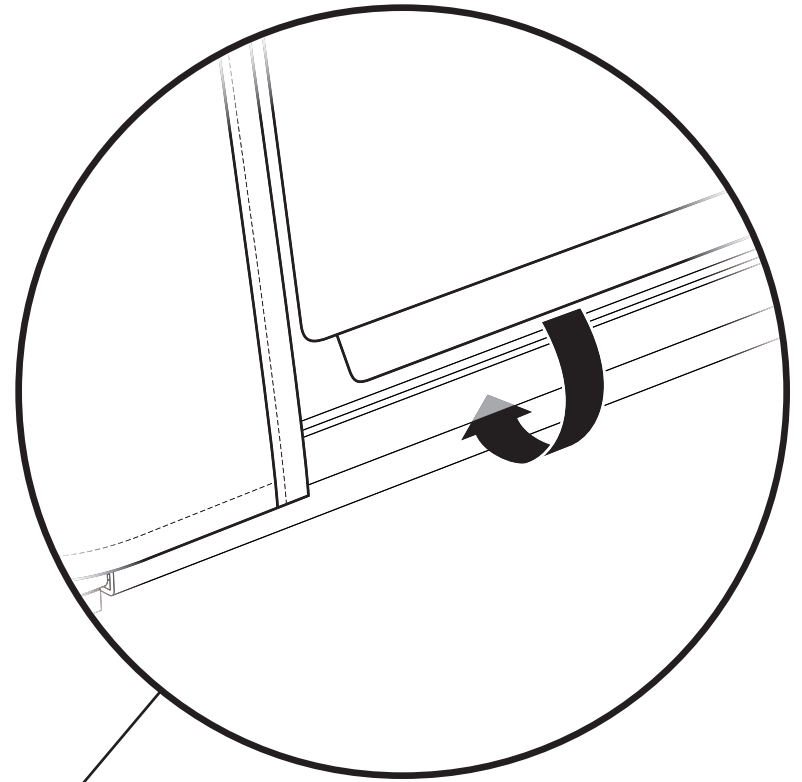

Step 2

Tuck the plastic tab along the bottom edge of each Side Curtain into the slot along the side of each Side Rail.

Tuck the plastic tab along the bottom of the Rear Window into the slot along the side of the Rear Rail.



## Section 13 Install Center High-Mount Stop Light

Step 1

Hardware Kit #576.71

Step 2 CHMSL

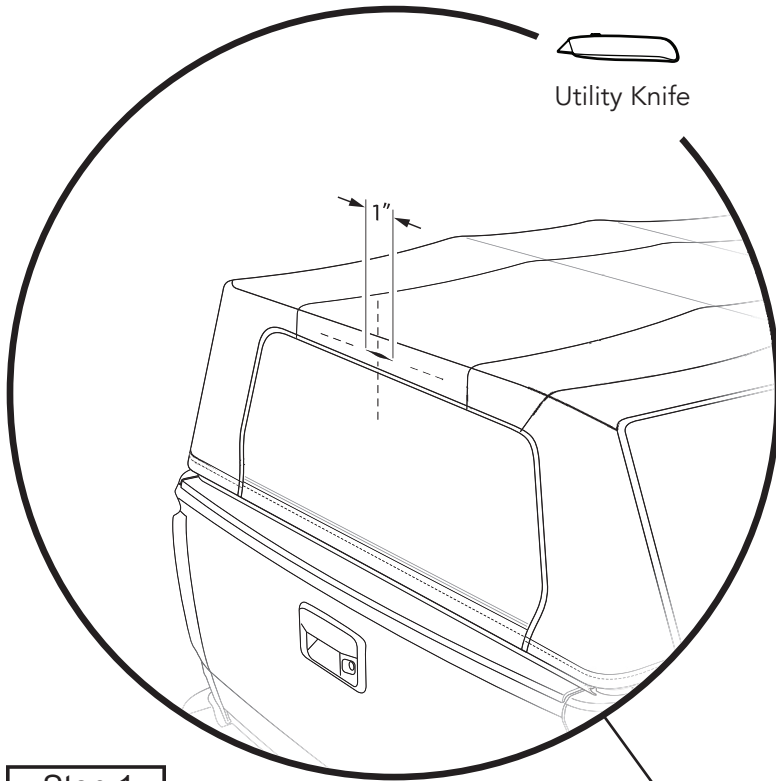

Utility Knife

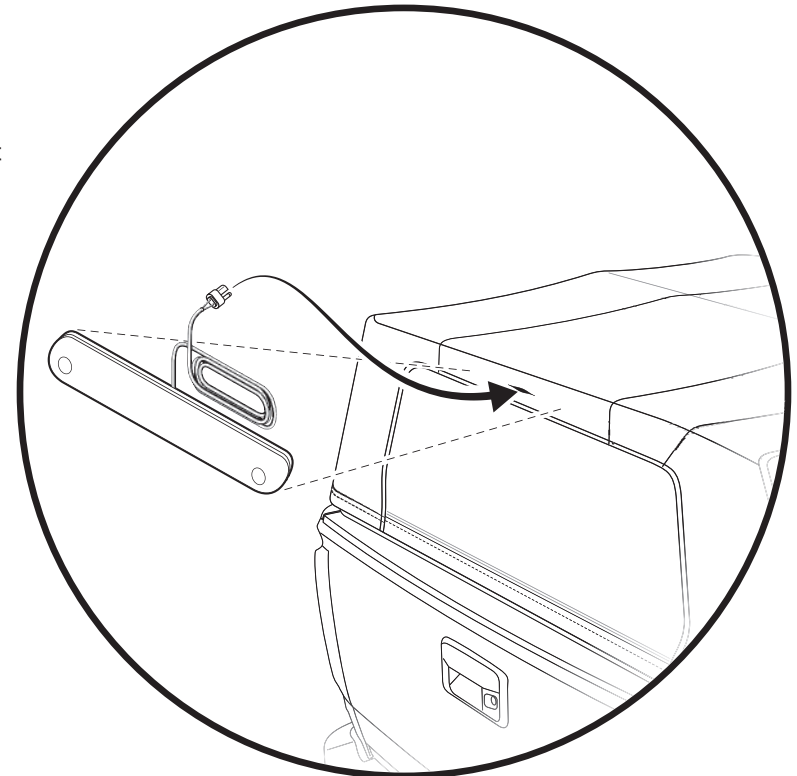
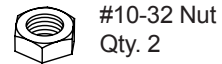
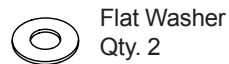
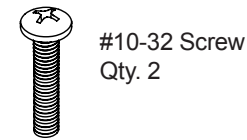
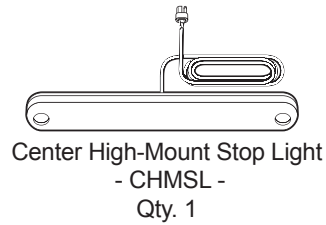

Step 1

Using a utility knife, cut a 1" wide slit through both layers of fabric in the area above the middle of the rear window, and in the vertical center of the fabric.

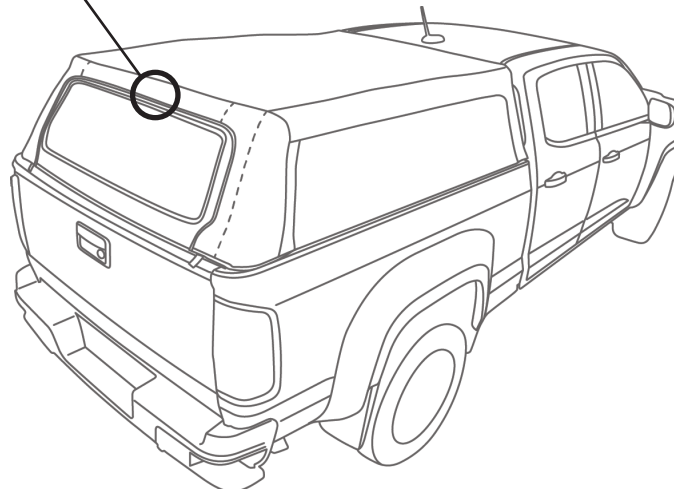

Step 2

Feed the connector end of the CHMSL wire harness through the slit in the top fabric, and pull the wire all the way through.

Make sure that the light is centered, straight and level, and attach the Stop Light to the top fabric using two (2) 10-32 Screws, two (2) Flat Washers and two (2) 10-32 Nuts. The Nuts and Flat Washers go on the inside of the fabric.

You'll need to pierce the fabric for the screws to go through.

## Section 14 Feed Wire Harness Through Sleeves

Step 1

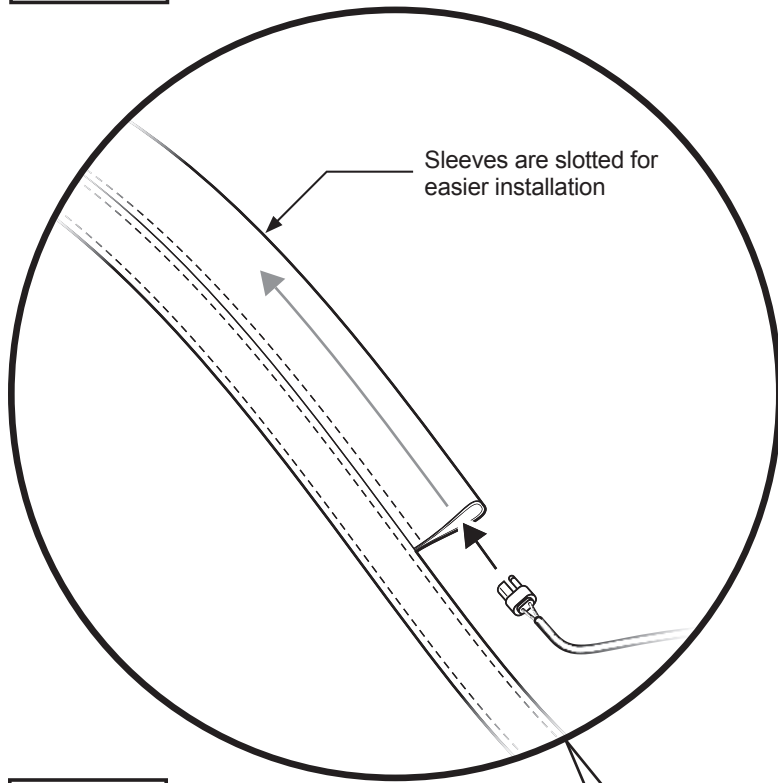

Detail

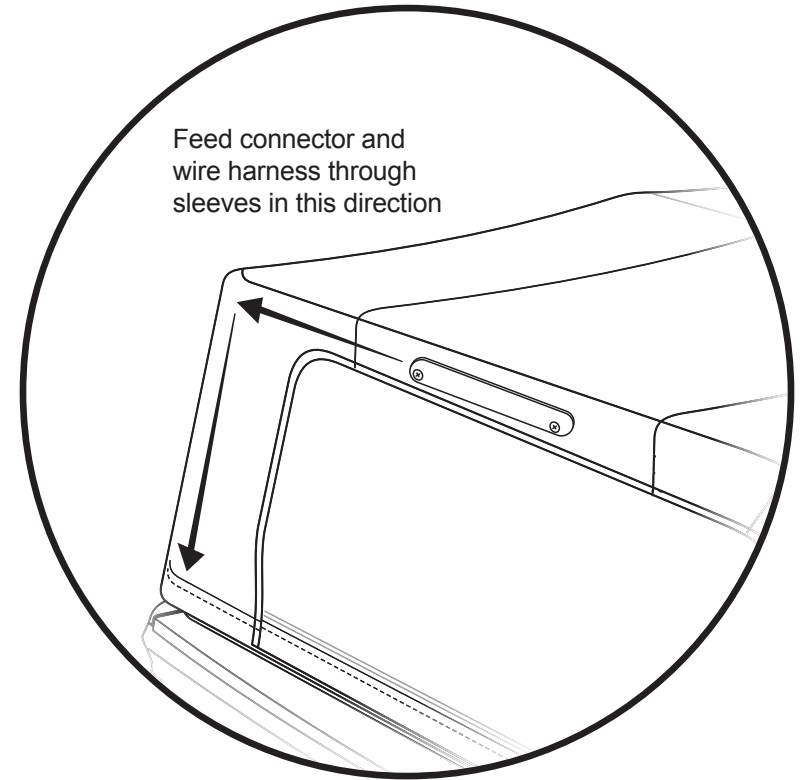

Step 1

Feed the connector and wire harness through the fabric sleeves on the inside of the top.

The sleeves run across the top and down the rear corner of the top fabric.

**NOTE:** Sleeves are slotted to help with installation.

See Detail.

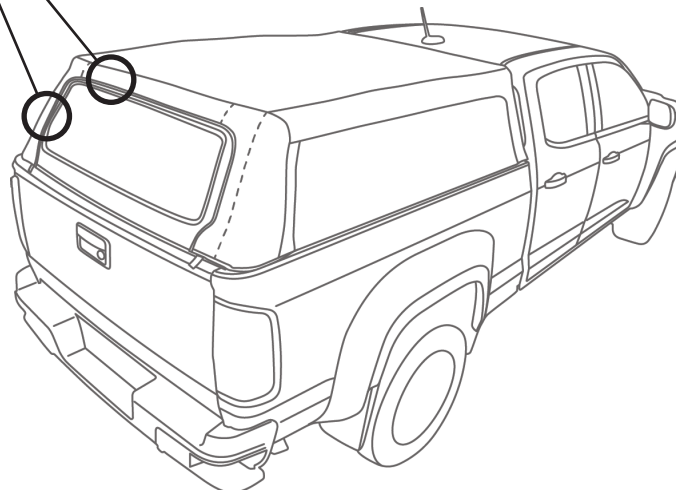

## Section 15 Install 29' Wire Harness & Splice Into Existing Wiring

### Step 1

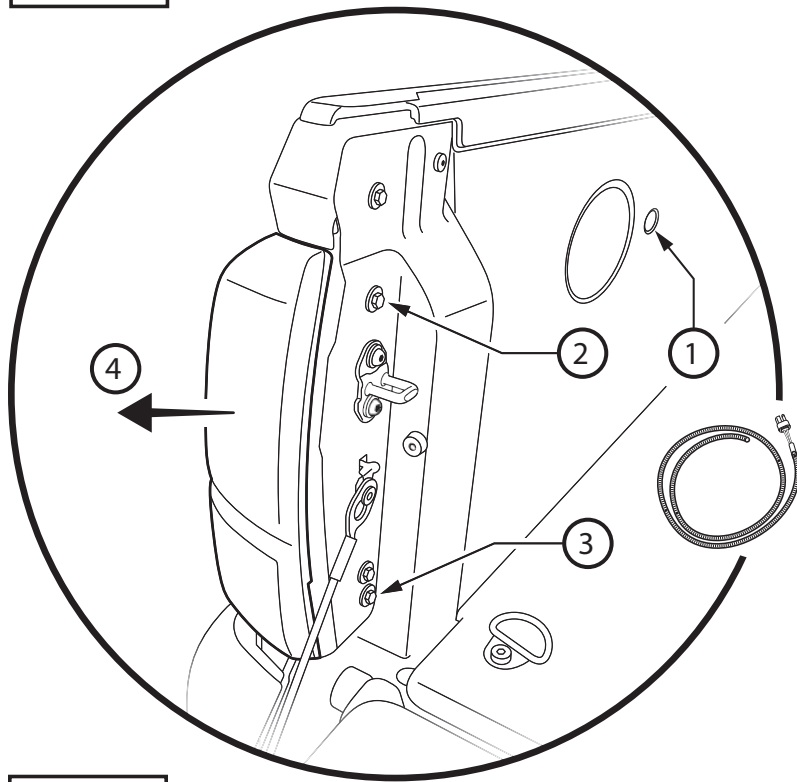

### Step 1

Cut the 29' wire harness 4' (48") from the end with the connector. Feed the cut end through the side of the bed at location ① and through the slot underneath the edge of the cap. Leave about 5" of the wire harness with the connector inside the vehicle bed.

Remove the driver's side tail light assembly.

Remove hex-head screws ② and ③ using a 10mm socket. ④ pull the driver's side tail light assembly away from the vehicle fender, and set it on the tailgate.

### Hardware



Wire Harness  
Cut to 4' length  
Qty. 1

### Tools



Wire Cutter

### Step 2 577.58

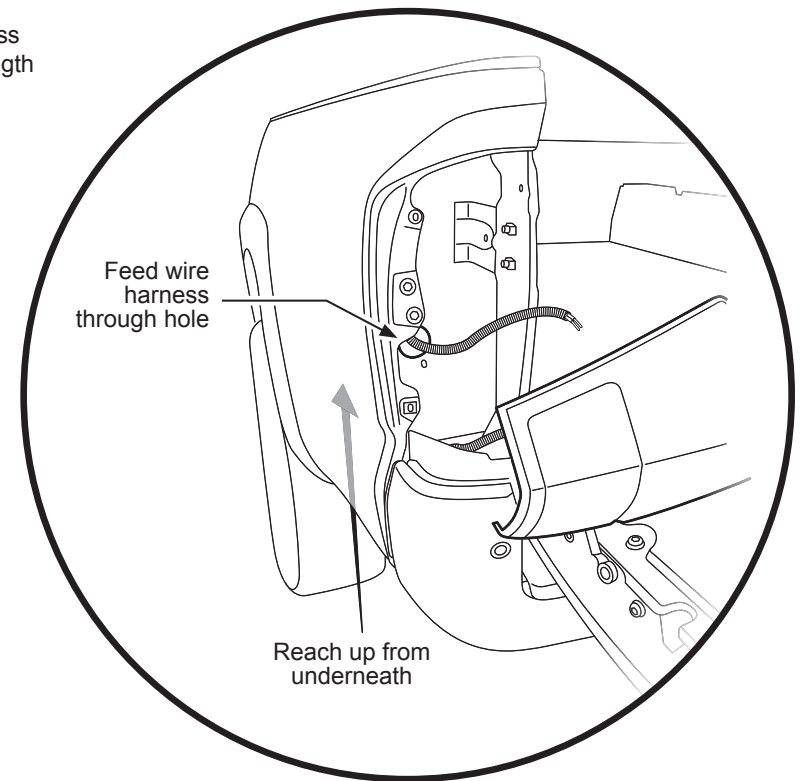

### Step 2

Reach up between the outer and inner fender to feed the 4' wire harness through the hole in the tail light receiver portion of the fender.

Pull the wire harness through the hole, and clip the end so it will reach the tail light wires with a bit of slack.

## Section 15 Attach Wire Harness Wires to Tail Light Wires

**Note: Wire connection for 2019-Current Ram models. If you have a 2009-2018 Ram Classic style skip to page 22.**

Step 1 577.58

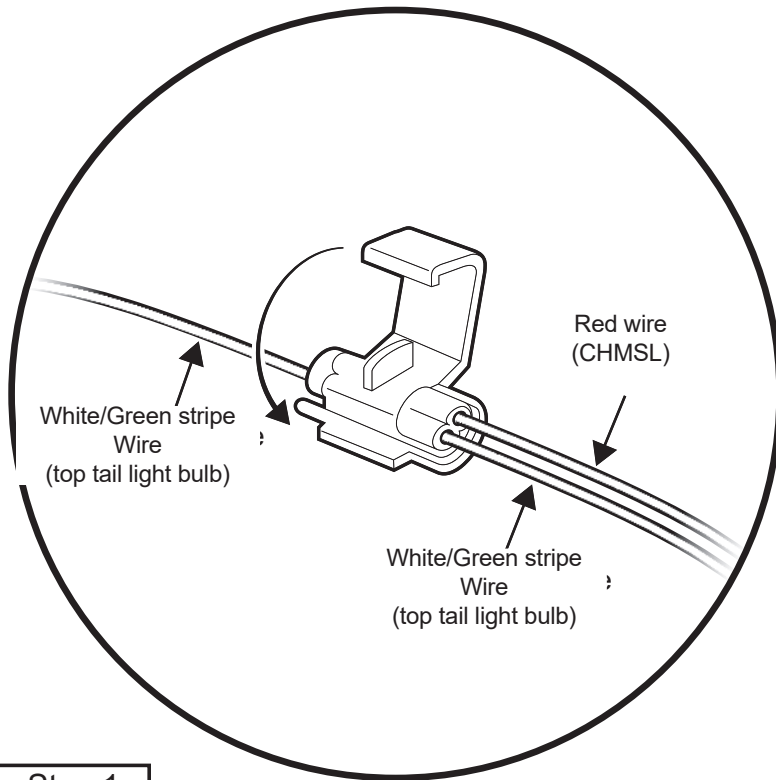

Step 1

On the back side of the driver-side tail light, locate the White/Green stripe and the solid Black wires going to the top bulb (brake light bulb).

Splice the White/Green Stripe wire from the tail light top bulb to the solid red wire from the CHMSL, using a Wire Tap #577.58 and a pair of pliers.



Wire Tap  
Part #577.58  
Qty. 2

Tools



Pliers

Step 2 577.58

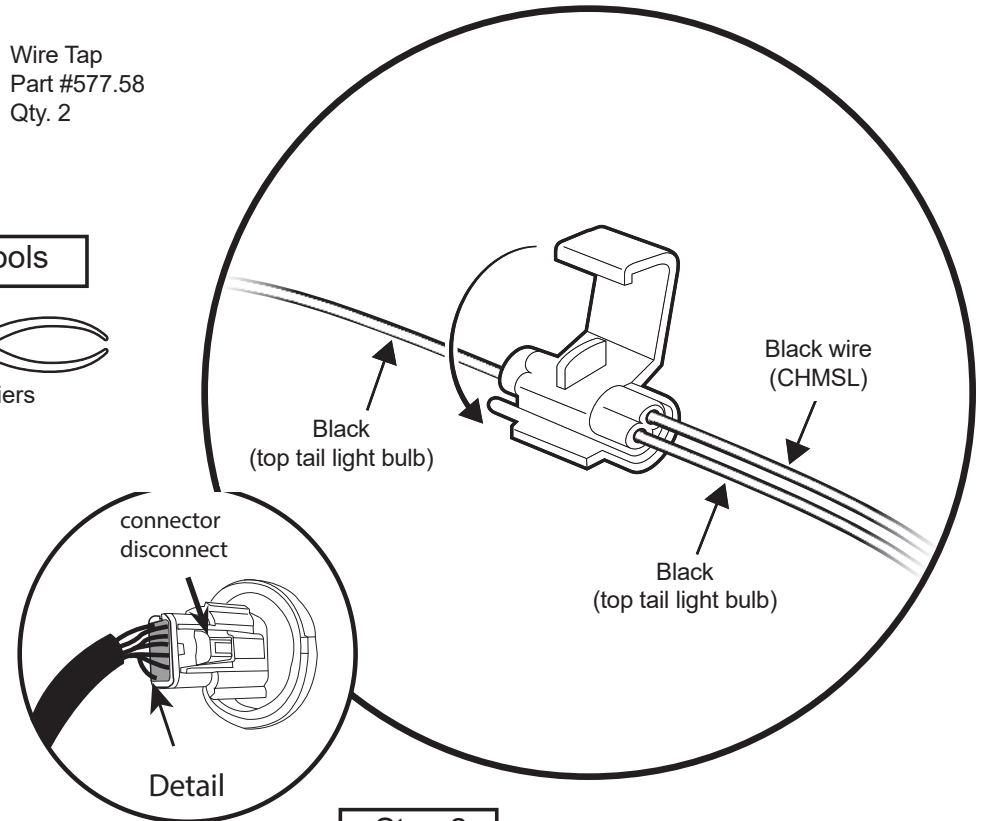

Step 2

Splice the Solid Black wire from the tail light top bulb to the Black wire from the CHMSL, using a Wire Tap #577.58 and a pair of pliers.

**NOTE:** There will be 2 black wires in the connector, be sure to use the black wire at the bottom of the connector away from the connector disconnect point. (See detail)

## Section 15 Attach Wire Harness Wires to Tail Light Wires

**Note: Wire installation for 2009-2018  
Ram Classic models.**

### Step 1

Remove both tail lights from vehicle. Follow installation instructions on 3rd brake module 590.34.

1st Yellow wire attaches to white w/ green stripe on LH tail lamp

2nd Yellow wire attaches to white w/ yellow stripe on LH tail lamp.

Green wire on module attaches to Red wire on 3rd brake light.

**NOTE: Wire from 29' harness can be used to attach the module to the 3rd brake light. Other connectors will need to be purchased to finish the installation.**

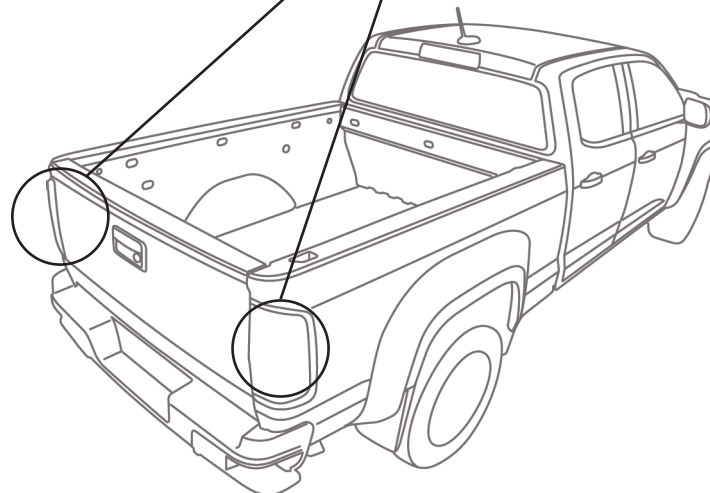
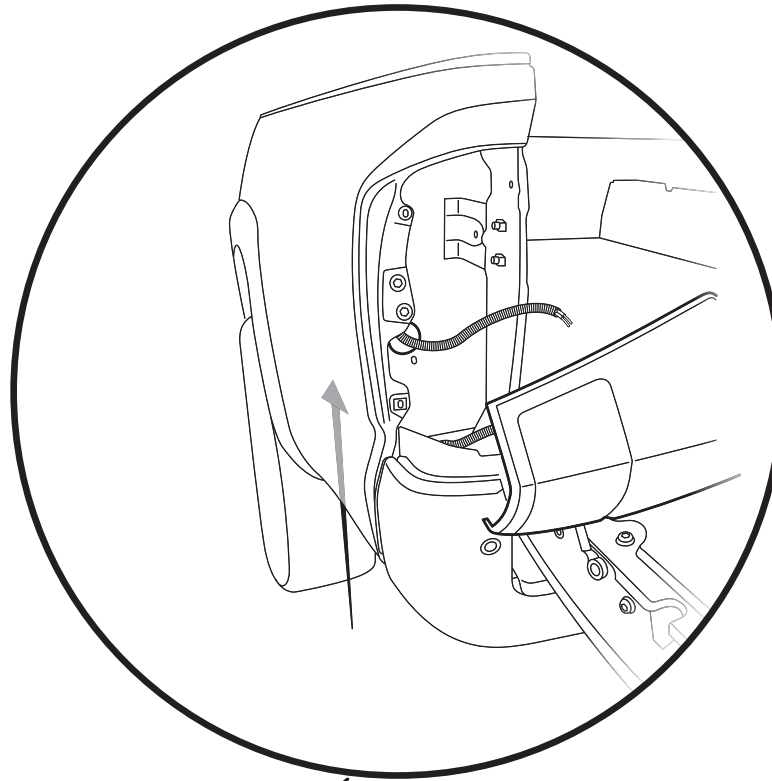

## Section 17 Opening and Storing the Top

Step 1

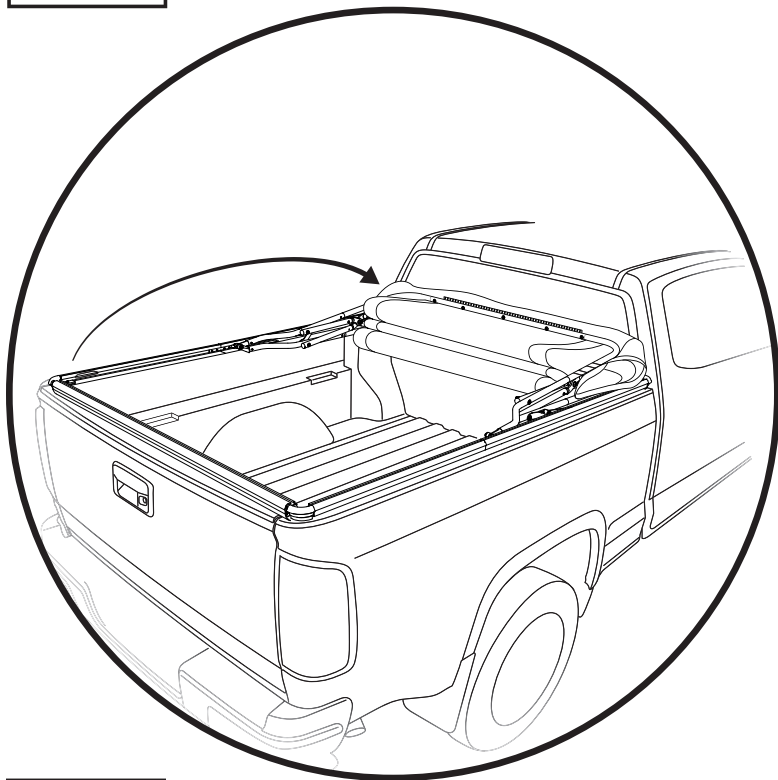

Step 1

To open the top:

Unzip and remove Side Curtains.

Unzip and remove Rear Window.

Release plastic tabs from rails all around.

Flip rear corners of top fabric up onto roof.

Fold the top forward so that all the bows collapse and rest on the Front Rail.

Step 2

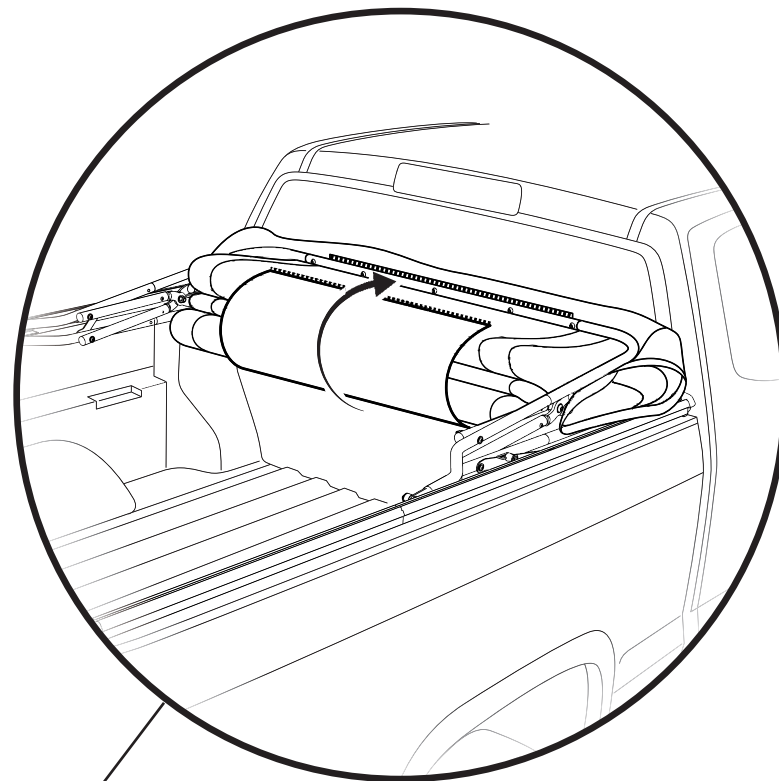

Step 2

Protect the top fabric by wrapping the Boot attached to the Front Window around the Fabric and Bows.

Secure the Boot by zipping it to the zipper for the Rear Window.

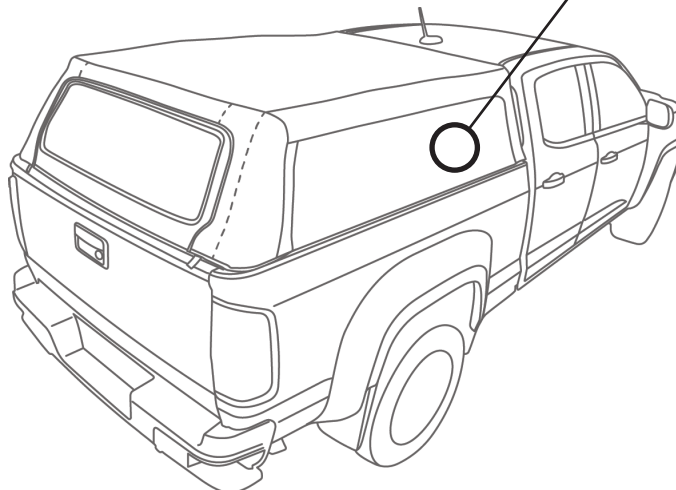

Section 18 Store Rear Rail When Top is Folded Down

Step 1

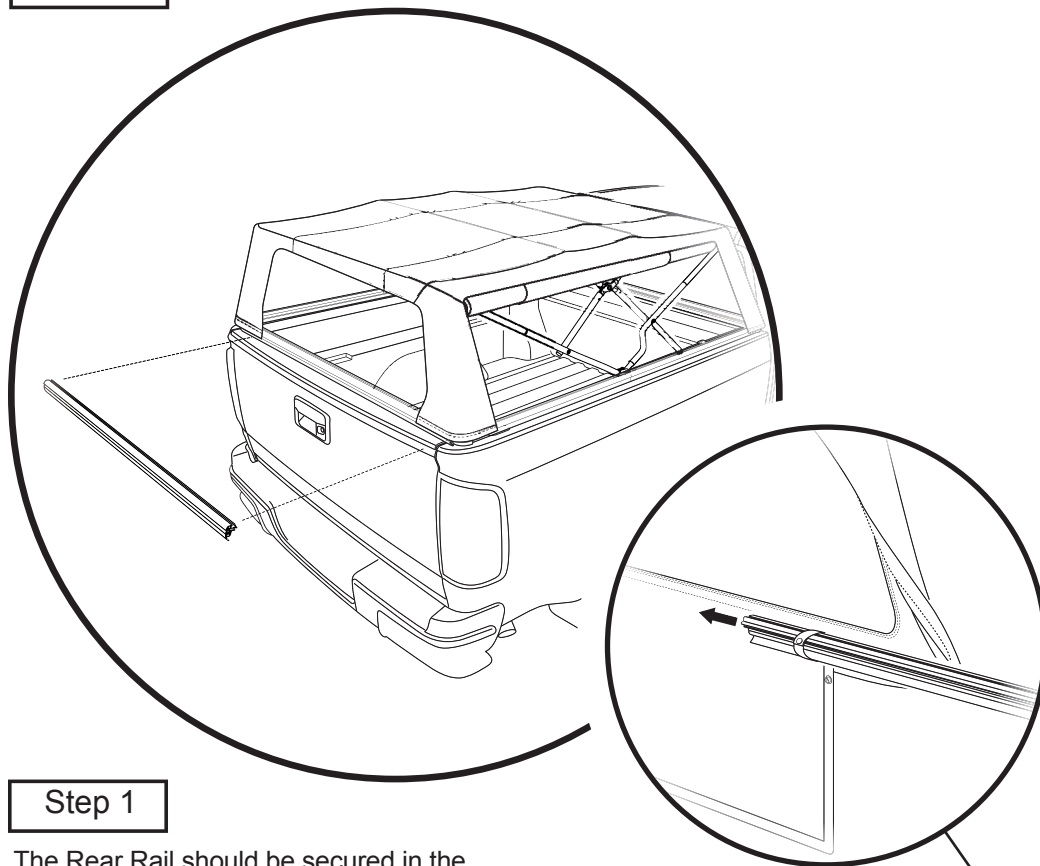

Step 1

The Rear Rail should be secured in the straps at the bottom of the Front Window when the top is folded down.

Wrap the straps around the Rear Rail and snap closed.

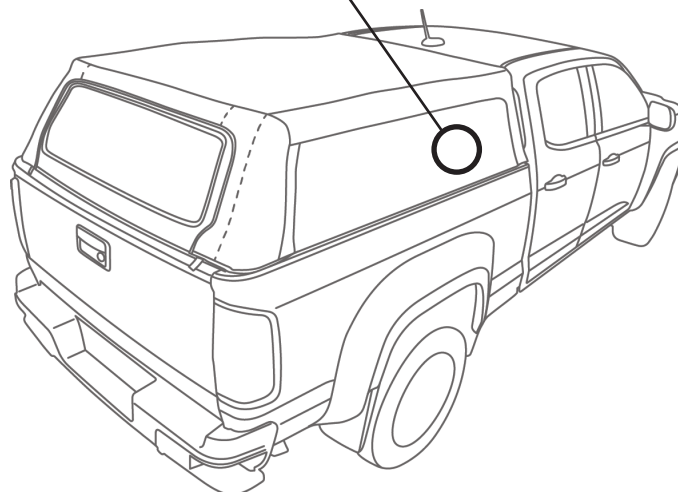

## Section 19 Storing the Rear Window; Rolling Up Side Curtains

Step 1

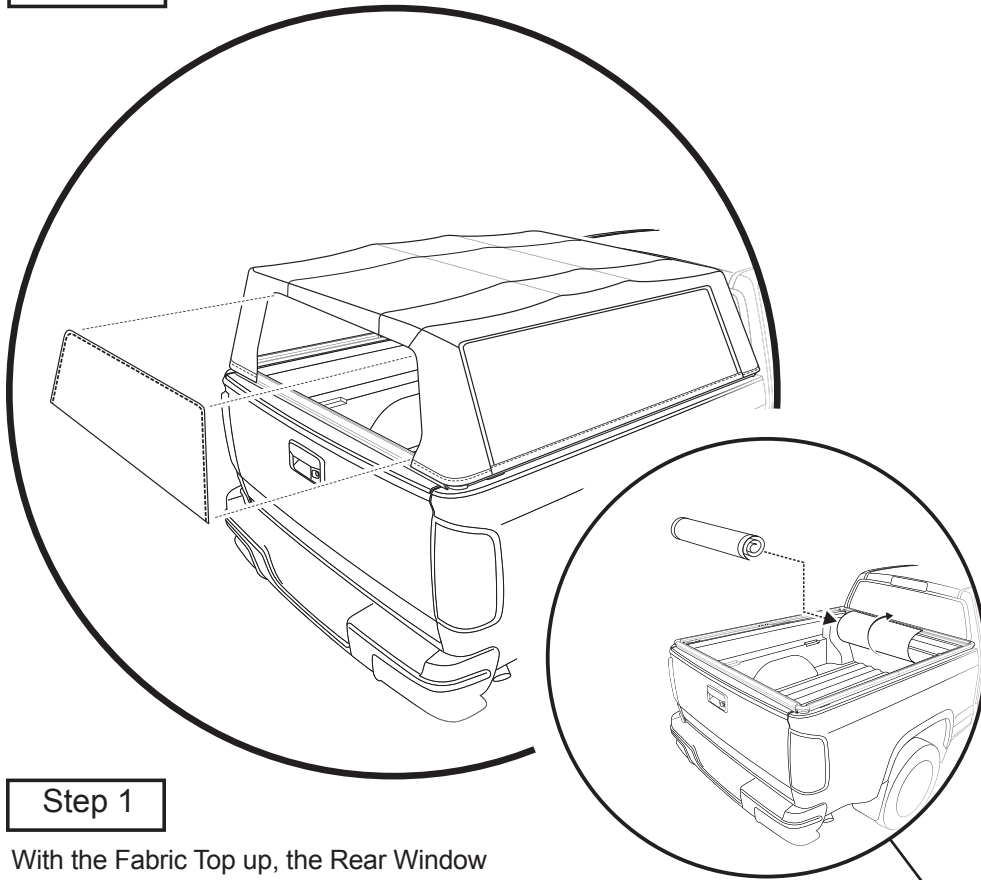

Step 1

With the Fabric Top up, the Rear Window can be stored in the Boot attached to the bottom of the Front Window.

Place the rolled-up Rear Window in the Boot, and zip the Boot closed.

Step 2

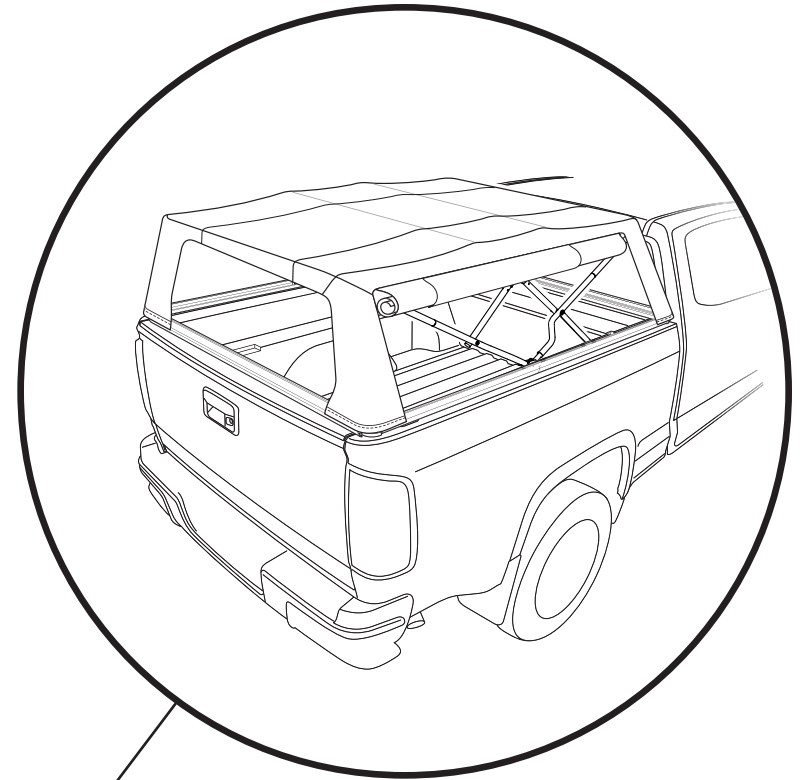

Step 2

With the Fabric Top up, the Side Curtains can be rolled up and secured with attached side flaps.

