



# Installation Instructions Supertop for Trucks

Vehicle Application:  
JEEP GLADIATOR 2020-Current 5' Bed  
Part Number 77326

## Installation Tips

Before you begin installing your new Supertop for Trucks, please read all the instructions thoroughly

It is recommended that two people install this Bestop product.

For a smooth fit:

For easier installation, the top should be installed at a temperature above 72° F. Below this temperature, the fabric may contract an inch or more, making it difficult to fit the vehicle. You may let the fabric sit in the sun for 15-20 minutes before installing to let the fabric warm up.

It is normal for the fabric to contract and wrinkle when stored in the shipping carton. Within a few days after installation, the fabric will relax and the wrinkles will disappear.









**WARNING** Do not rely in any way on the components of this product to protect against injury or death in the event of an accident. Never operate the vehicle in excess of manufacturer's specifications.

Read and follow, precisely, all installation instructions provided when installing this product. Failure to do so may result in a poor fit and could place occupants of the vehicle in a potentially dangerous situation.

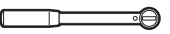

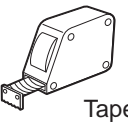
**CAUTION** Safety glasses should be worn at all times when installing this product.

**WEAR SEAT BELTS AT ALL TIMES**

Tools				Installation Time	
 Safety Glasses	 1/4" Allen Wrench	 Torque Wrench	<b>2 00</b> 2 hours		
 Ratchet	 9/16" Socket	- OR -  9/16" Wrench			
 Tape Measure			   		
			3 - Moderately Difficult		



# Installation Instructions Supertop for Trucks

Vehicle Application:  
JEEP GLADIATOR 2020-Current 5' Bed  
Part Number 77326

## Parts List

**Parts Kit #603.11**

 Lower Clamp (for track system) Part #582.07 Qty. 4	 Track Block Part #581.61 Qty. 4	 Flange Head Bolt 3/8-16 x 2.25" Part #581.75 Qty. 4 9/16" Hex Head	 1" Socket Bolt Part #581.76 Qty. 4 1/4" Allen Head
 Lower Clamp -Small Part #595.34 Qty. 4	 Upper Clamp Part #582.06 Qty. 4	 Bow Coupler #1 & #4 Bows Part #573.77 Qty. 2	 Bow Coupler #2 & #3 Bows Part #573.79 Qty. 2



# Installation Instructions Supertop for Trucks

Vehicle Application:  
JEEP GLADIATOR 2020-Current 5' Bed  
Part Number 77326

## Parts List

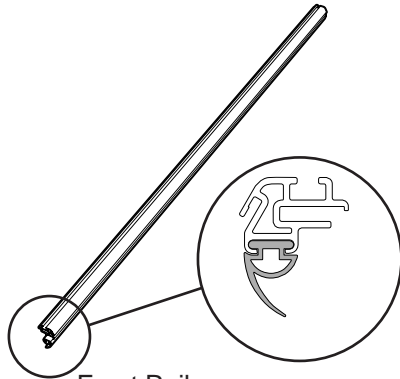

Front Rail  
Part #603.80  
Qty. 1

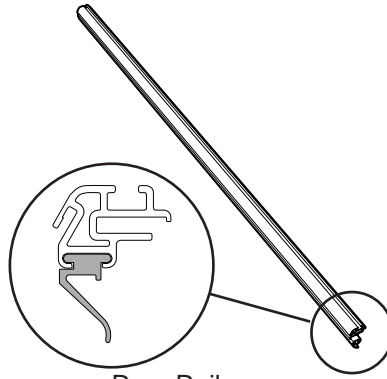

Rear Rail  
Part #603.84  
Qty. 1

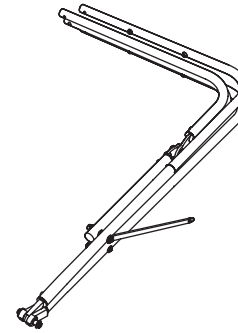

Bow Stack -  
Passenger Side  
Part #603.10  
Qty.1

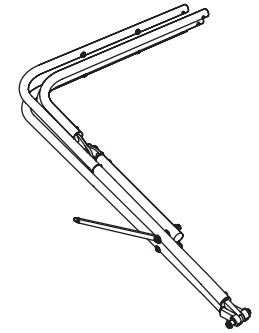

Bow Stack -  
Driver Side  
Part #603.09  
Qty.1

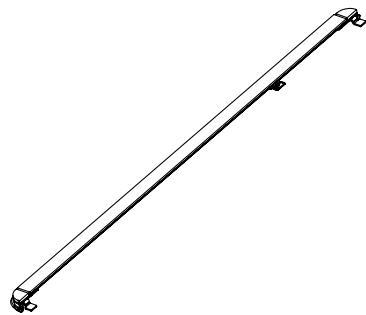

Left Side Rail  
Part #603.75  
Qty. 1

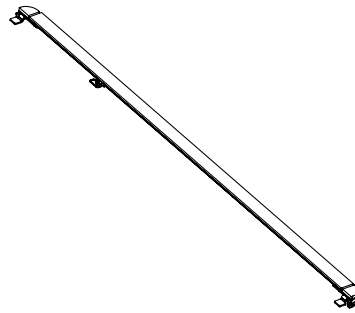

Right Side Rail  
Part #603.76  
Qty. 1

Left Side Curtain  
Fabric Top  
Rear Window  
Right Side Curtain

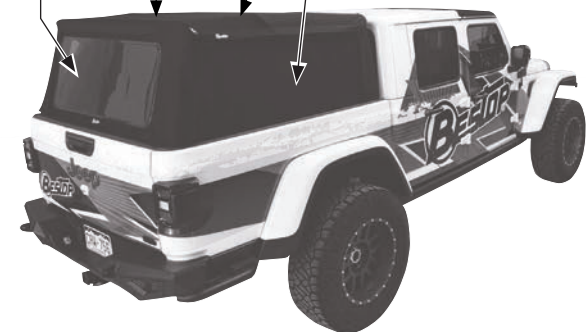

## Section 1 Place Rails (Part 1)

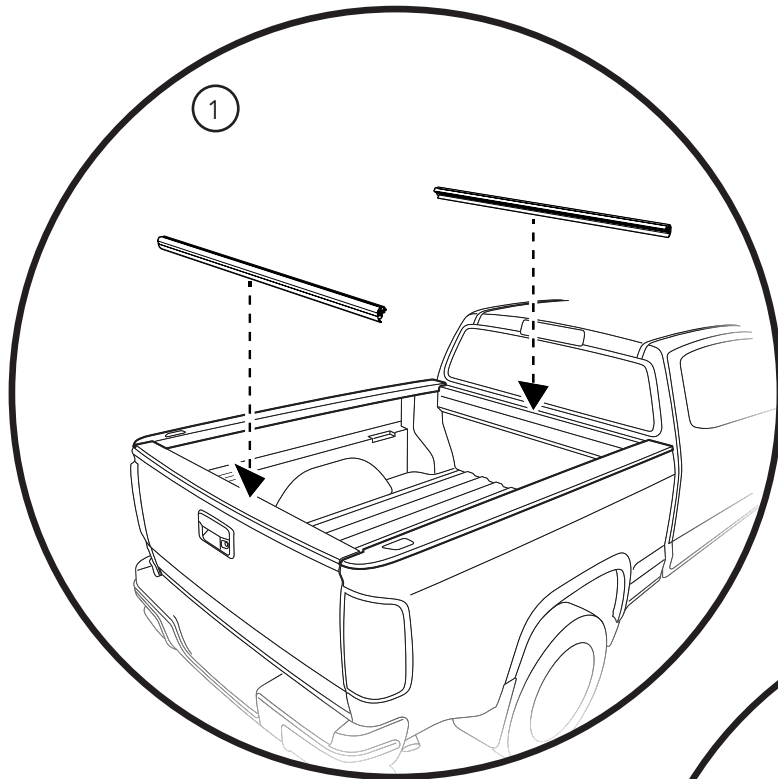

- 1 Place the Front Rail #603.80 and Rear Rail #603.84 onto the truck bed. Lay the Rails on top of the truck bed in front, and on top of the plastic bed protector at the rear.
- 2 Place Side Rails #603.76 (Right) and #603.75 (Left) onto the truck bed. Lay the Rails on top of the plastic bed protectors.

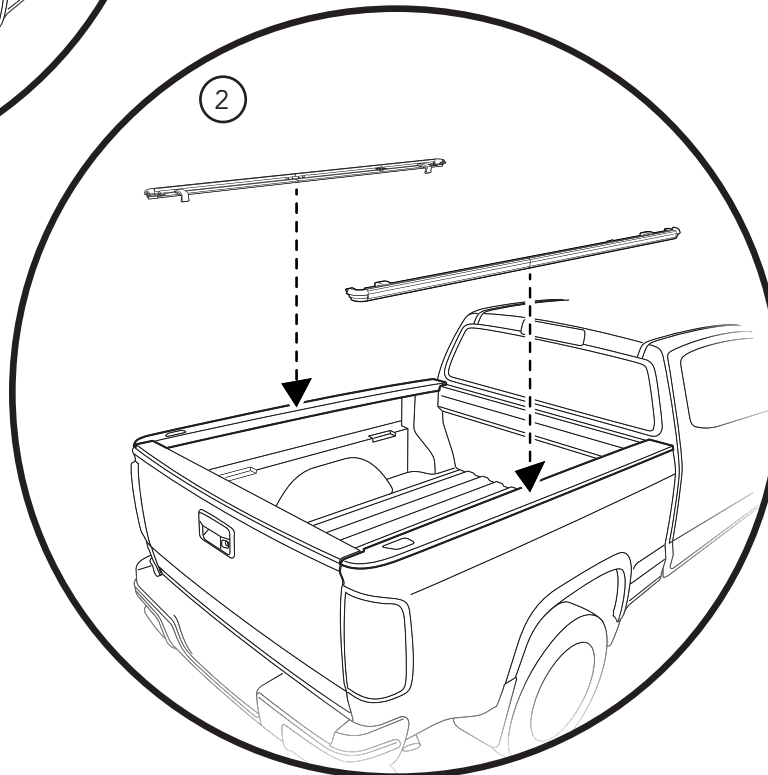

### Hardware

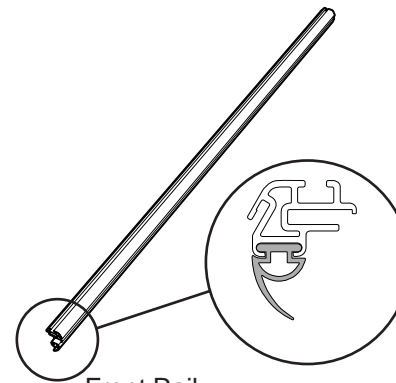

Front Rail  
Part #603.80  
Qty. 1

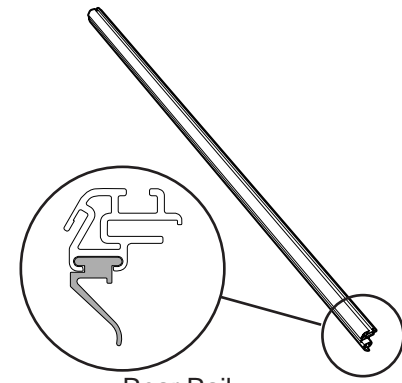

Rear Rail  
Part #603.84  
Qty. 1

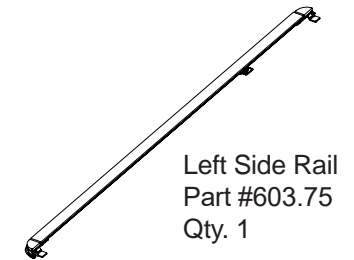

Left Side Rail  
Part #603.75  
Qty. 1



Right Side Rail  
Part #603.76  
Qty. 1

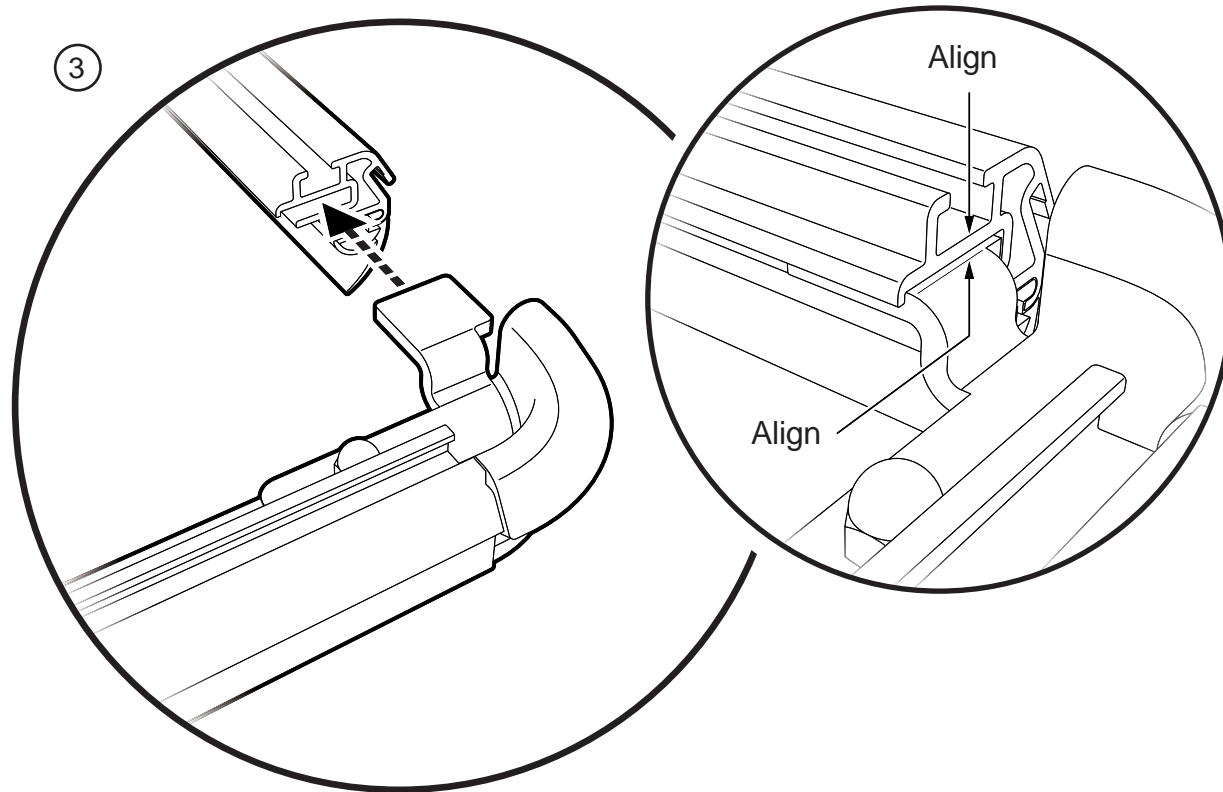

- ③ Attach the Front and Rear Rails to the Side Rail Assemblies.

Slide the tabs at the front and rear of the Side Rail Assemblies into the slots in the Front and Rear Rails.

Make sure that the ends of the Front Rail and Rear Rail extrusions are aligned with the tongue of the attachment feature, where the tongue bends, and the small corner protrudes.

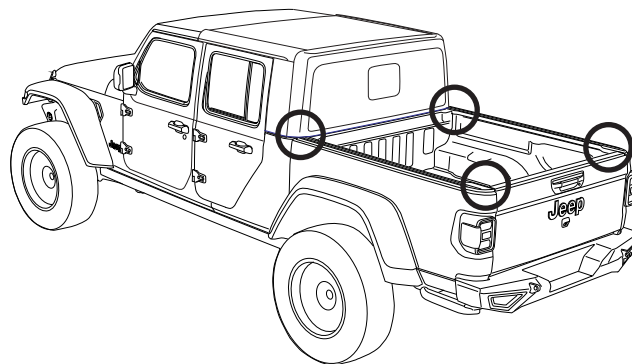

## Section 2 Install Upper Clamps

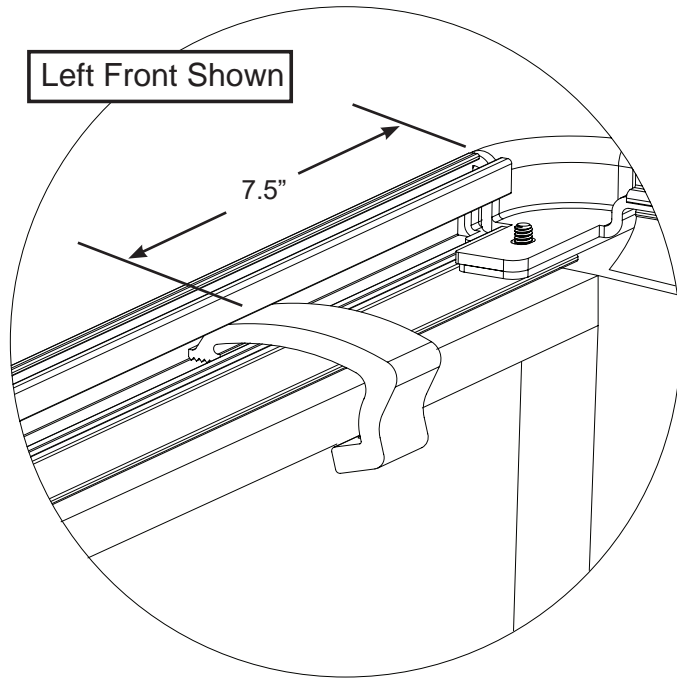

### Hardware

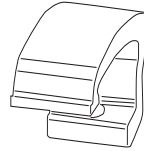

Upper Clamp  
Part #582.06  
Qty. 4

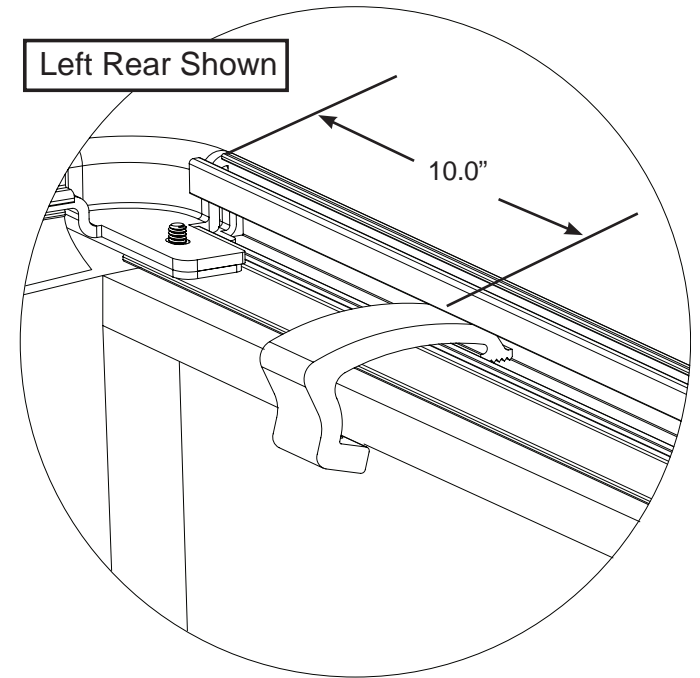

Slide upper clamps into side rails.

**Note:** To help with installation of upper clamp it is better to pick rail up off of bed, then rotate the clamp into the Side Rail.

The Upper Clamps should be located 7.5" from the front edge and 10" from the rear edge of the Side Rail.

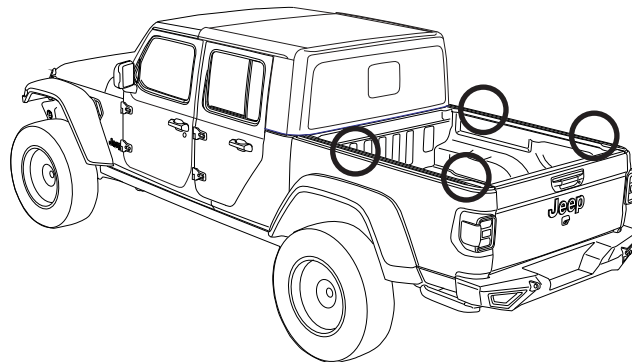

Hardware

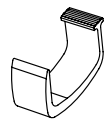

Lower Clamp -  
Small  
Part #595.34  
Qty. 2



Hex Head Bolt  
Part #581.75  
Qty. 4

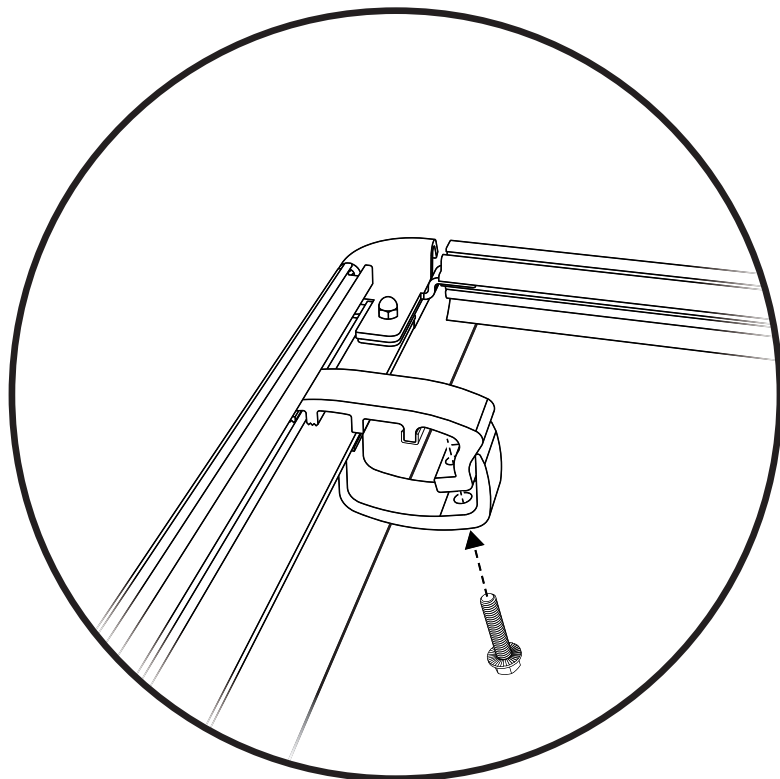

Attach Lower Clamps #595.34 to the front and rear upper Clamps, using one Hex Head Bolt #581.75 for each clamp.

Check alignment of the Rail Assembly and tighten all bolts.

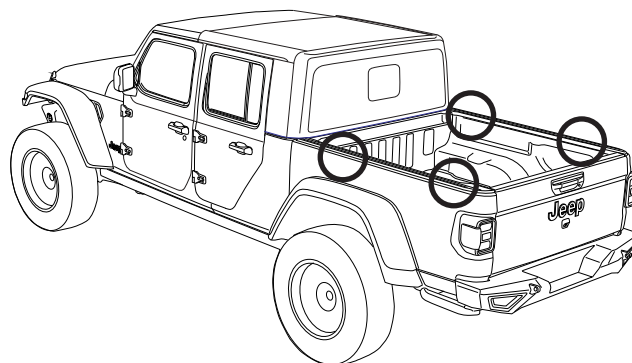

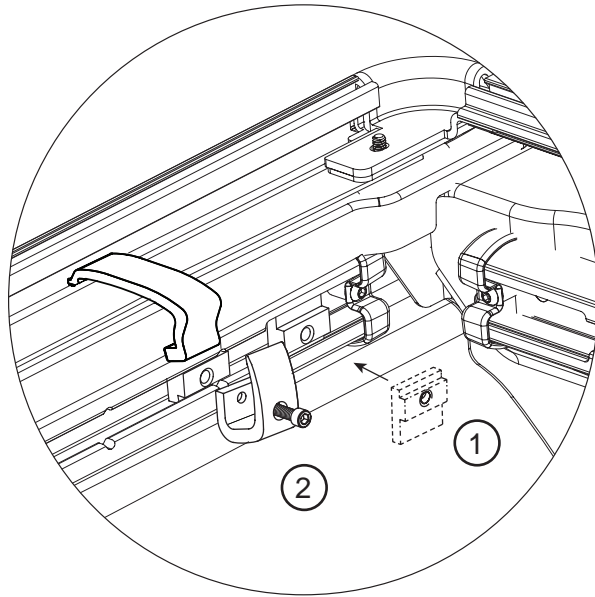

Tools

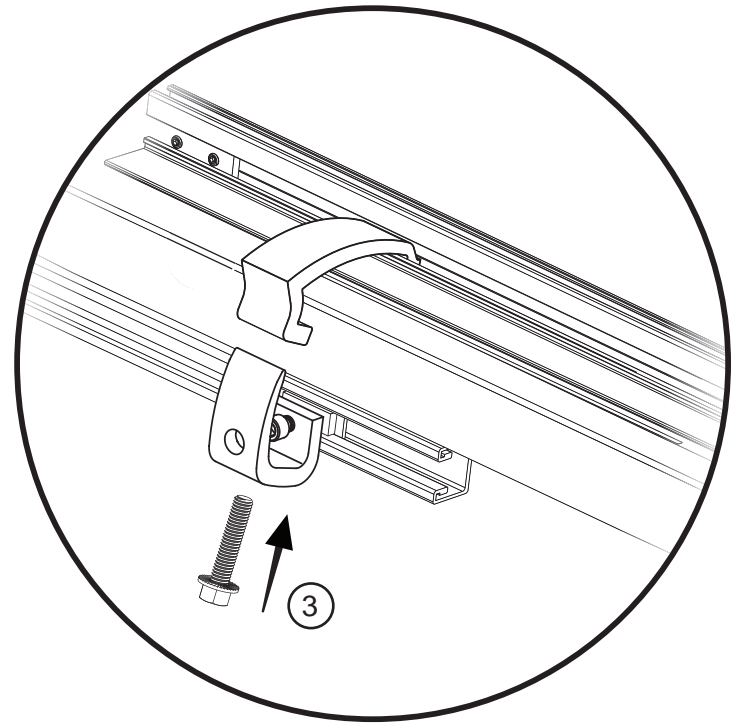
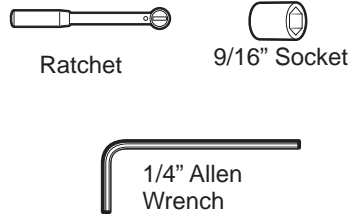

**Note:** If you have tie downs installed in track, they must be removed before this step.

- 1 From the end of the track, install 1 track block (581.61) into track. Slide the block until it lines up with the front outer clamp.
- 2 Attach a lower track clamp (582.07) to the Track Block using screw (581.76). \*Only hand tighten the screws.
- 3 Attach a lower Clamp (582.07) to an Upper Clamp using 1 Flange Head Bolt (581.75).

Repeat steps on the remaining 3 clamps.

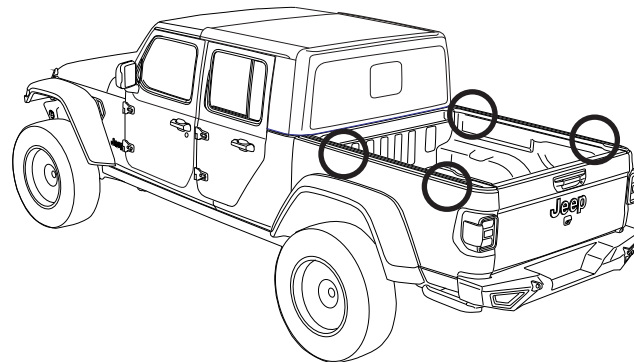

Hardware

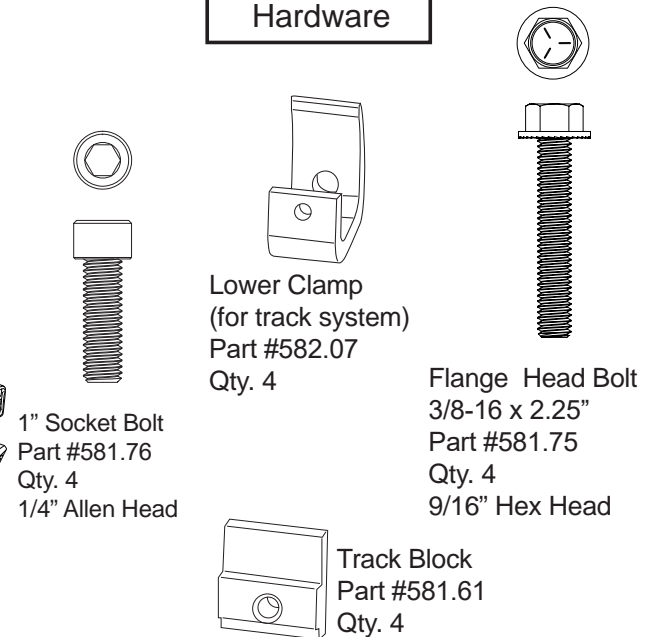



## Section 4 Align Rail, Tighten Fasteners and Slit Front Rail Seal

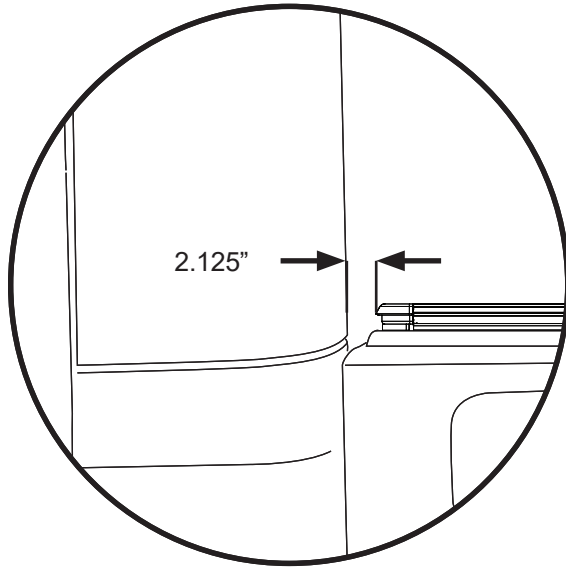

Place the outer edge of both side rail corners 2.125" from the back side of the vehicle cab.

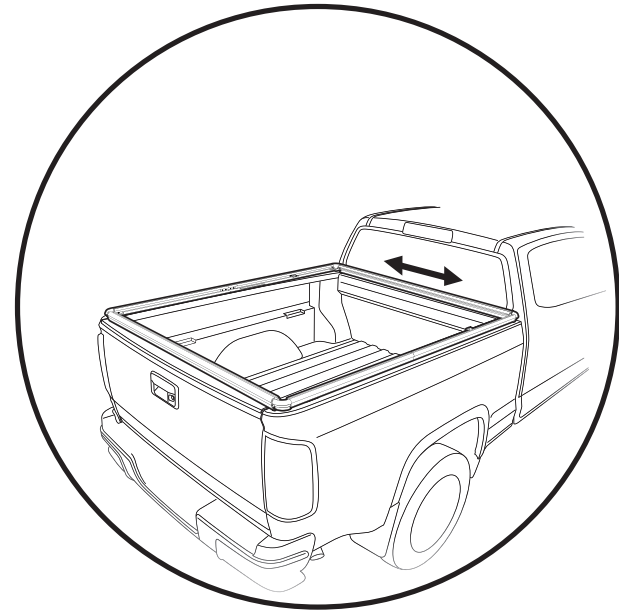

Adjust the Side and Front and Rear Rail assembly right-to-left to center it on the bed width. Tighten clamps to 55 in/lbs.

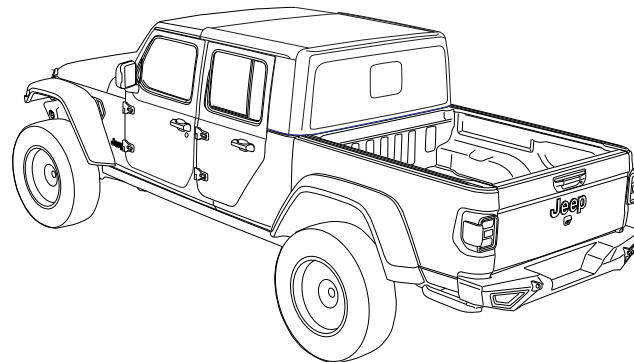

## Section 5 Assemble the Bows

### Hardware

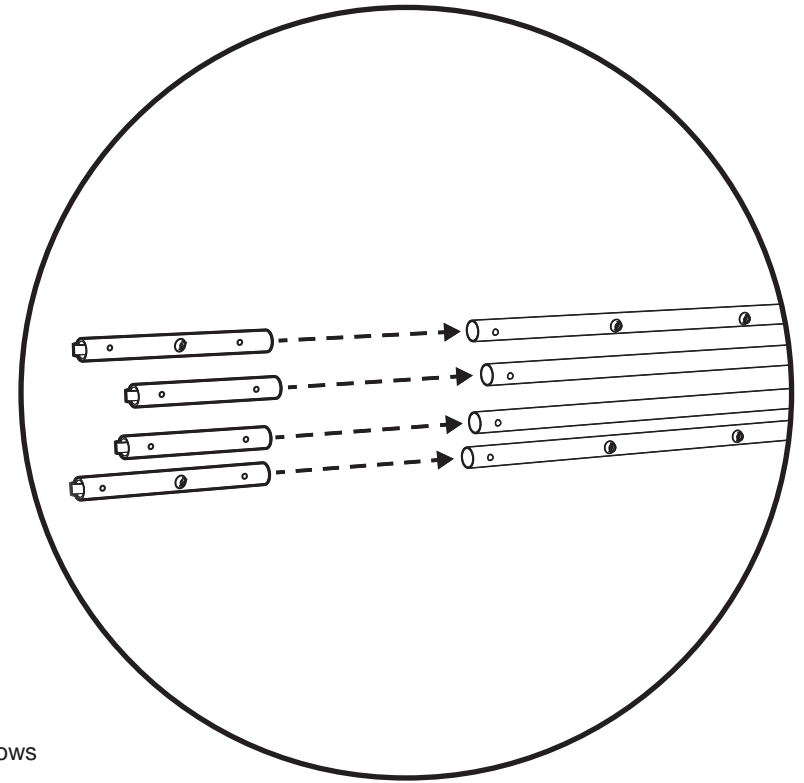
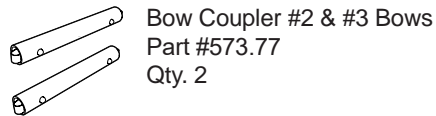
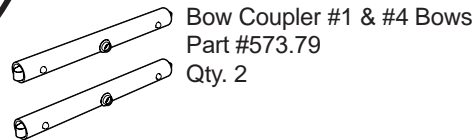
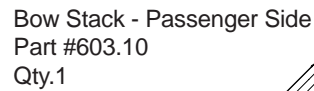
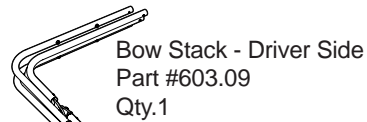
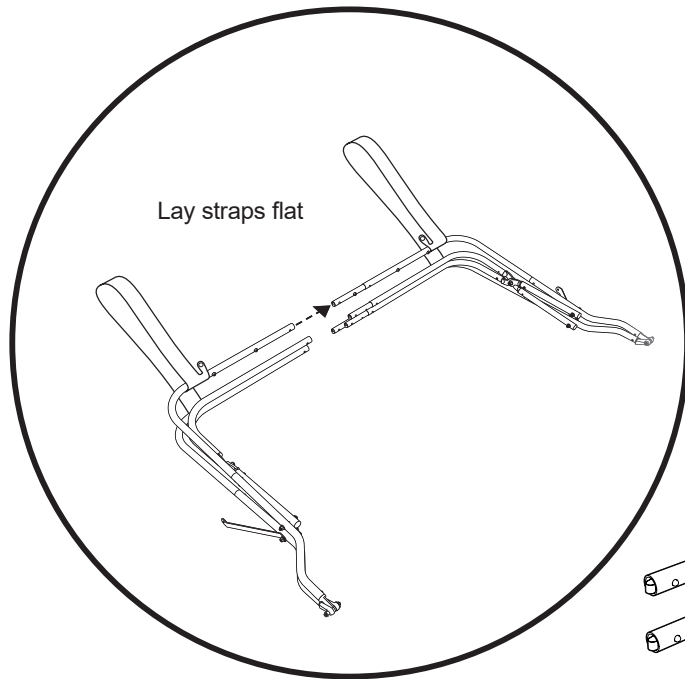

**Note:** Before attaching couplers to bow stacks, make sure to pull the bond coat straps out and away from the bows, and lay them flat.

Attach Bow Couplers #573.77 and #573.79 to the Passenger Side Bow Stack #603.10

Insert Long Couplers #573.79 into the outer bows #1 and #4.

Insert Short Couplers #573.77 into the inner bows #2 and #3.

### For Easier installation:

Slide all bows and couplers together before snapping the spring clips into the holes in the bows.

Slide the Couplers installed in the Passenger Side Bow Stack into the ends of the bows on the Drivers Side Bow Stack #603.09.

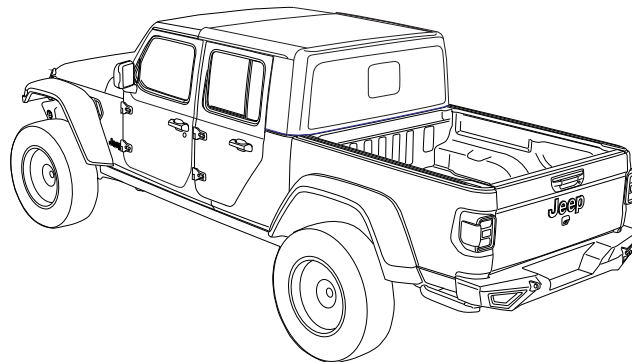

## Section 6 Install Bow Assembly

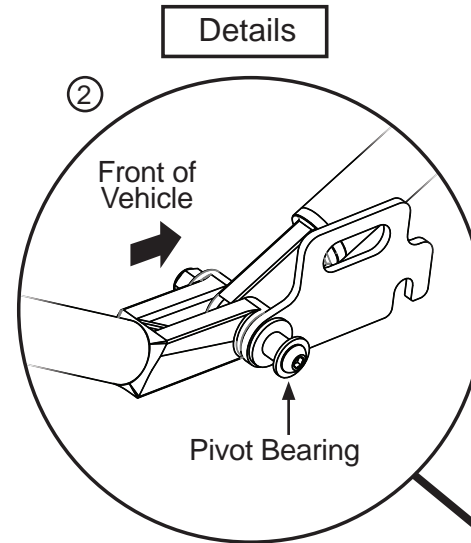
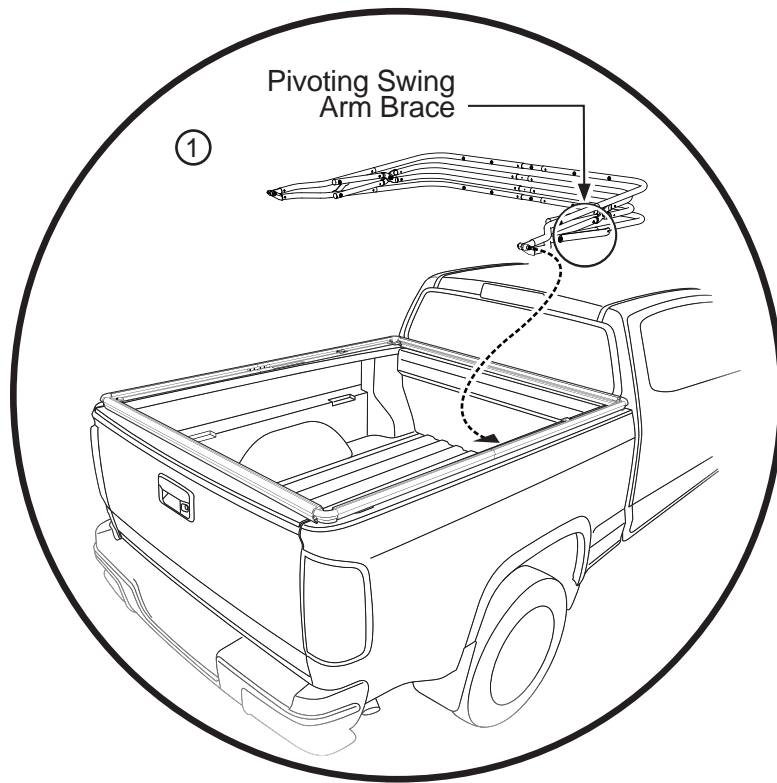

Passenger Side Shown

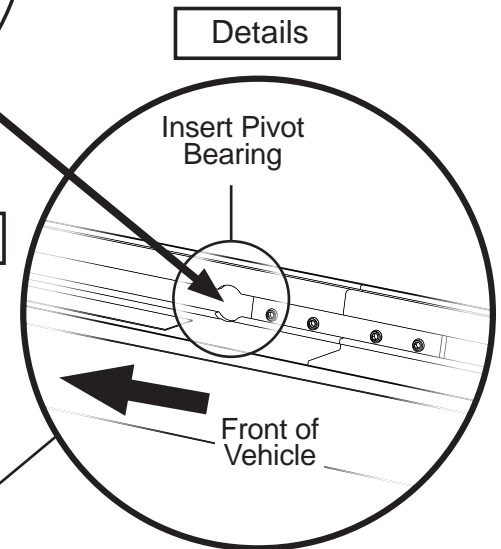

**Note:** Two People Are Required for this Part of the Installation.

- 1 Place the folded Bow Assembly on the Side Rails. Make sure that the pivot swing arm braces are on the lowest bow.
- 2 Insert the Pivot Bearings into the receiving holes in the inside of the side rails See Details.

Repeat on left side of vehicle.

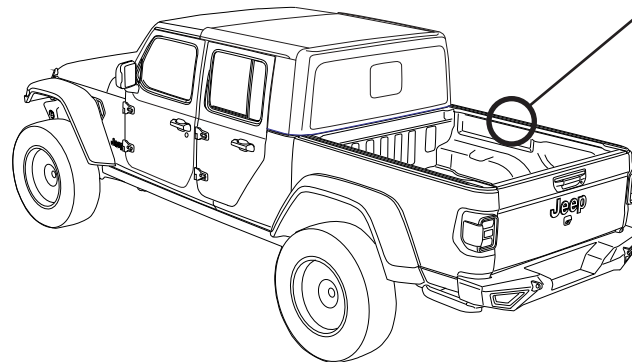

## Section 7 Unfold Bows; Attach Pivot Arm Braces; Engage Locking Levers

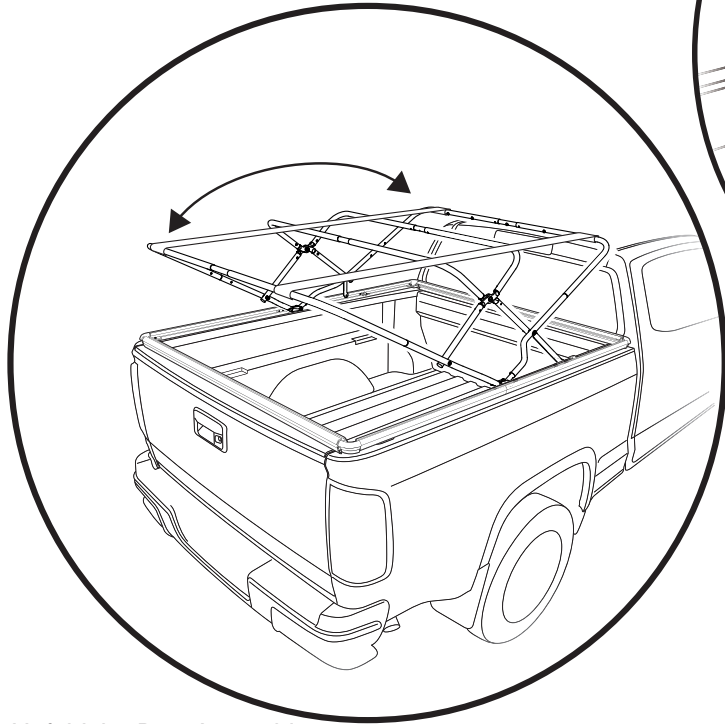

Unfold the Bow Assembly.

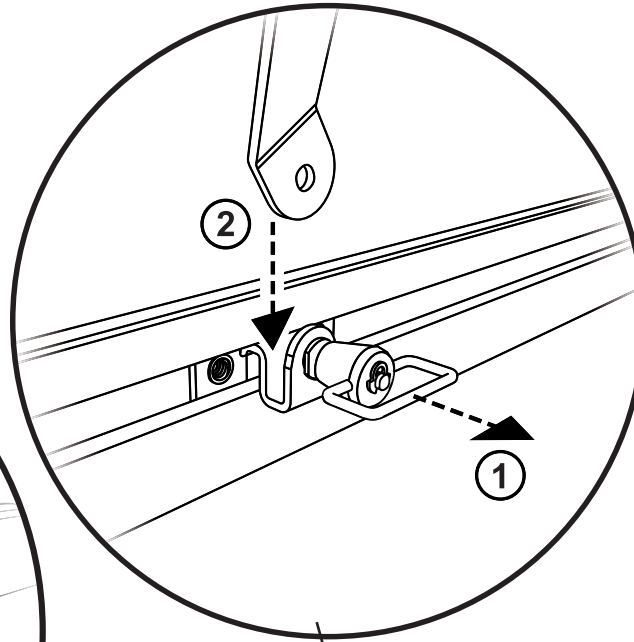

- ① Pull back on the Pivot Knuckle release knob;
- ② Snap the Pivot Arm Brace into place, on both sides of the truck.

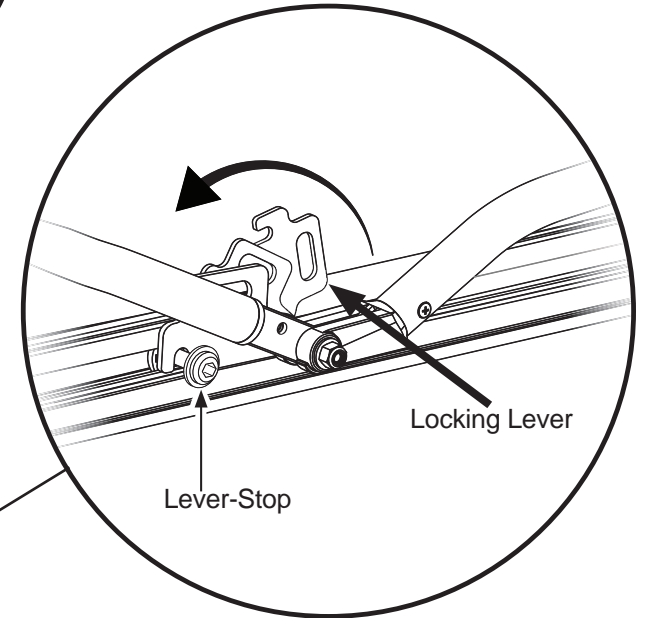

Engage the Locking Lever on both sides of the truck.

**Note:** The Lever-Stop Assemblies are pre-installed at the factory at 24.5" from the front edge of each Side Rail.

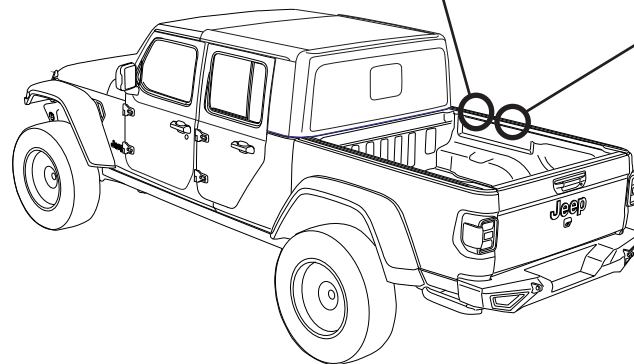

**Section 8** Lay Folded Top Fabric on Bows; Unfold Top Fabric

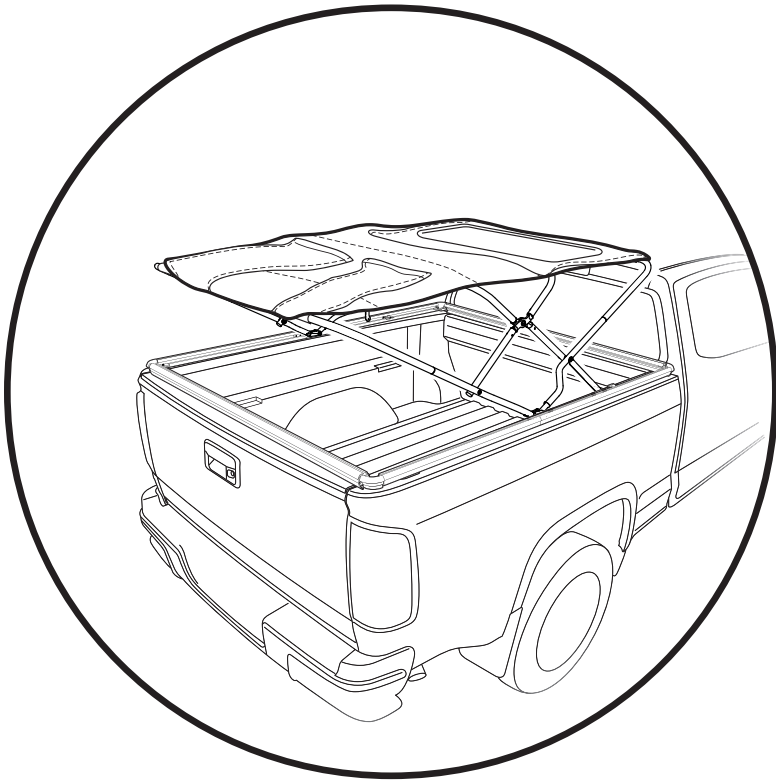

Place the folded Soft Top onto the unfolded Bow Assembly.

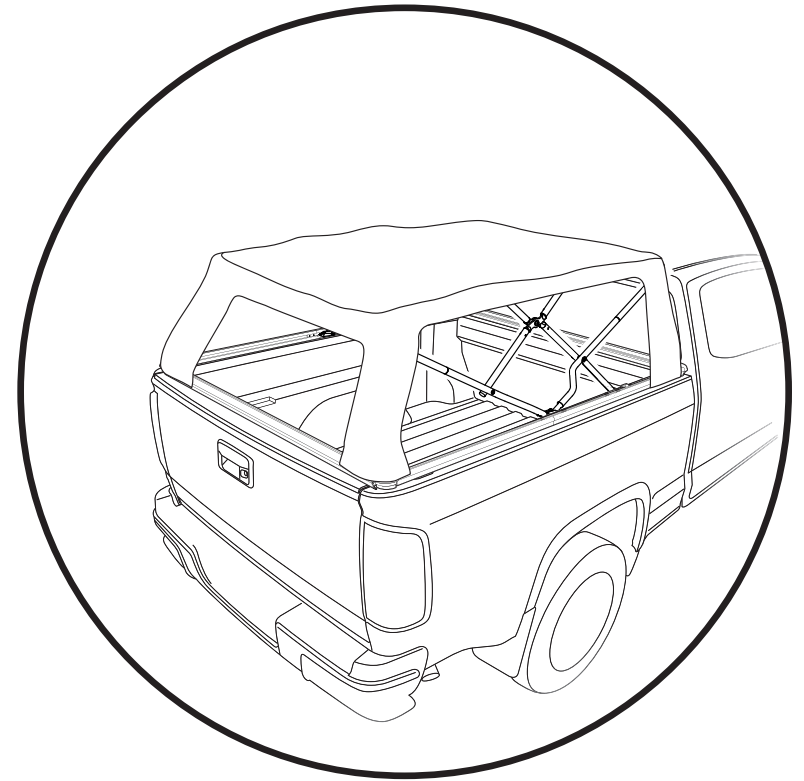

Unfold the front and back of the Top over the #1 and #4 Bows.

**Note:** Window should go towards the front of the Bow Assembly.



## Section 9 Install Side Curtains

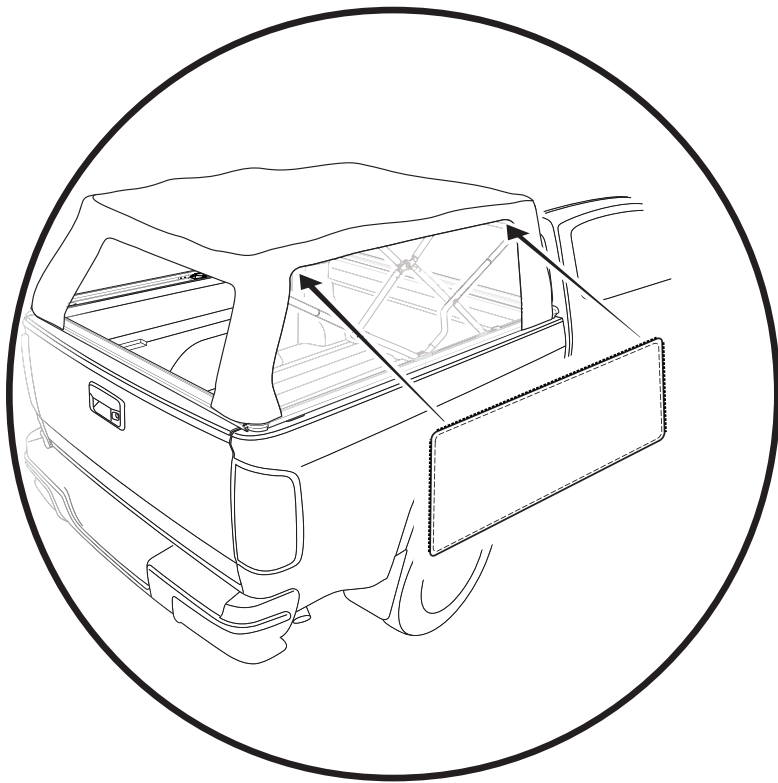

For easier access to the zippers, you may want to lift the corners of the top onto the roof fabric.

Zip the Rear Window and Side Curtains into place.

Start with the zipper along the top edge of each panel, and then follow with the side zippers. For ease of installation, start each zipper only about 6".

Once all zippers are started, flip the rear corners into the rail, then zip all zippers completely shut.

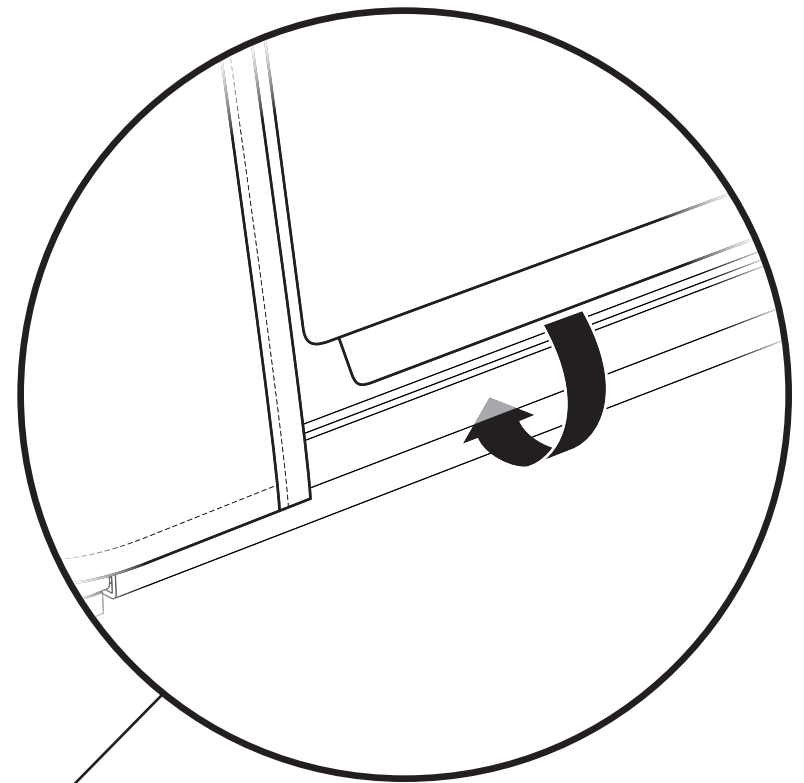

Tuck the plastic tab along the bottom edge of each Side Curtain into the slot along the side of each Side Rail.

Tuck the plastic tab along the bottom of the Rear Window into the slot along the side of the Rear Rail.

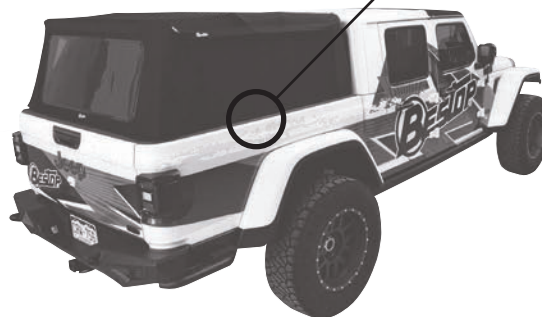

## Section 10 Secure Top Fabric to Bows

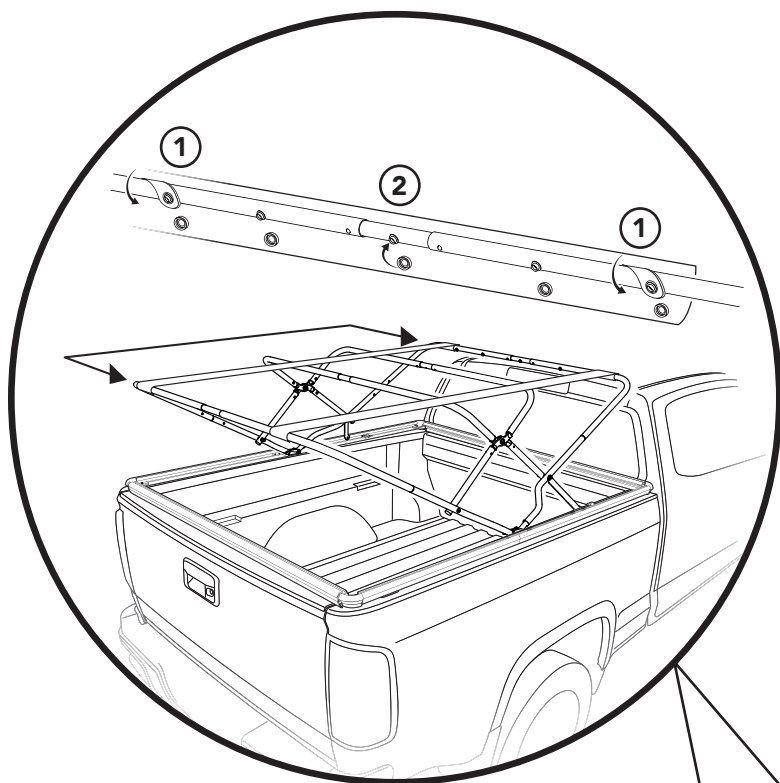

From inside the truck bed:

① Wrap the small flaps with holes over the outer-most snaps on the #1 bow (Bow closest to the truck cab).

② Wrap the fabric flap around the #1 Bow and snap all five snaps to secure the fabric to the Bow.

**Note:** Secure the outer snaps before securing the center snaps.

Repeat for the #4 Bow (Bow closest to the truck tailgate).

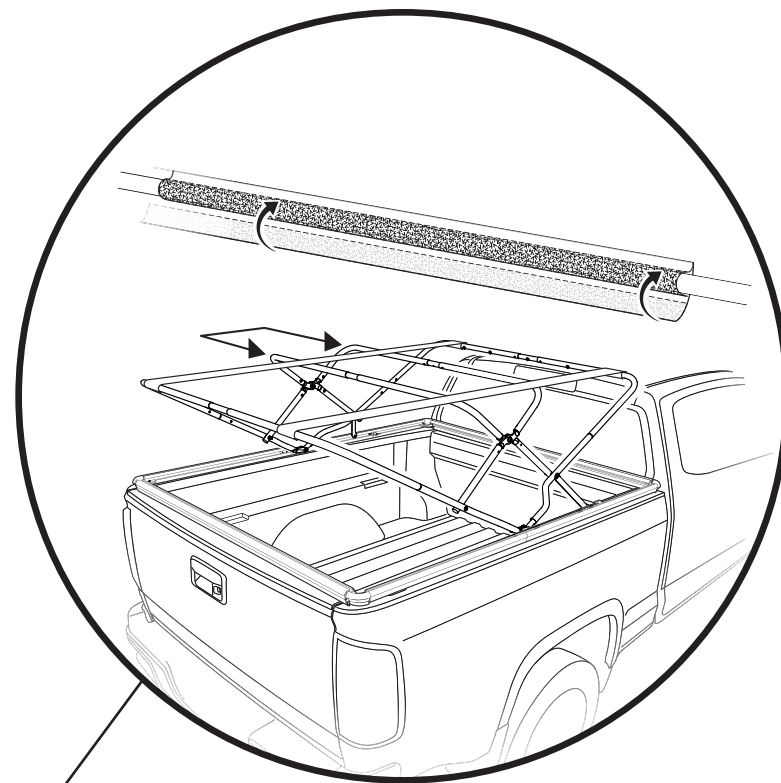

From inside the truck bed:

Wrap the fabric flaps with hook-and-loop around the #2 and #3 bows (the two middle bows) to secure the top fabric to these Bows.

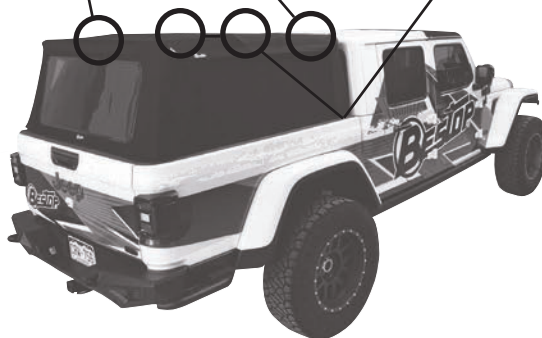

## Section 11 Slide Front Rail into Front Window

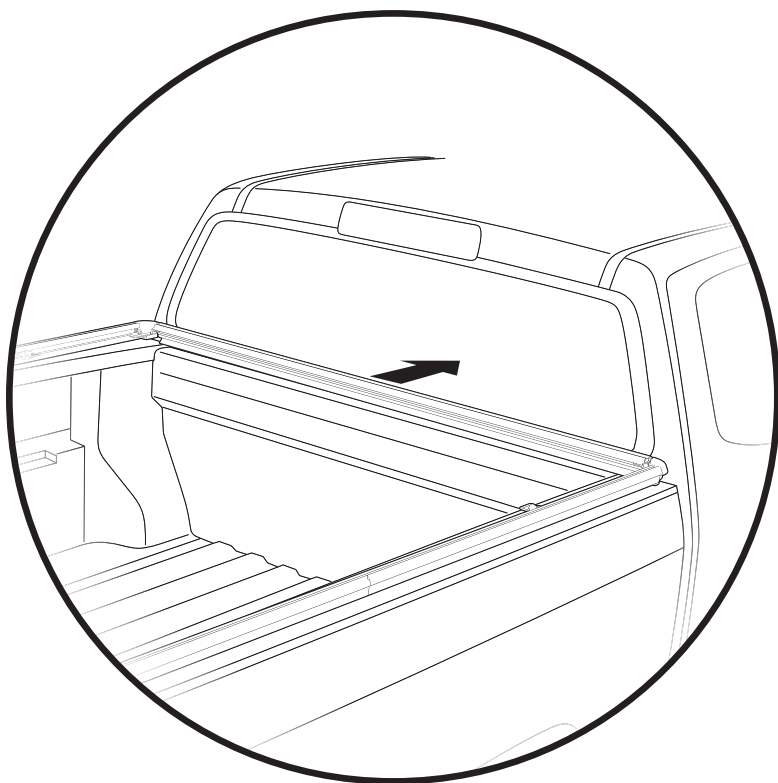

Remove the front rail, by sliding it toward the front of the truck bed.

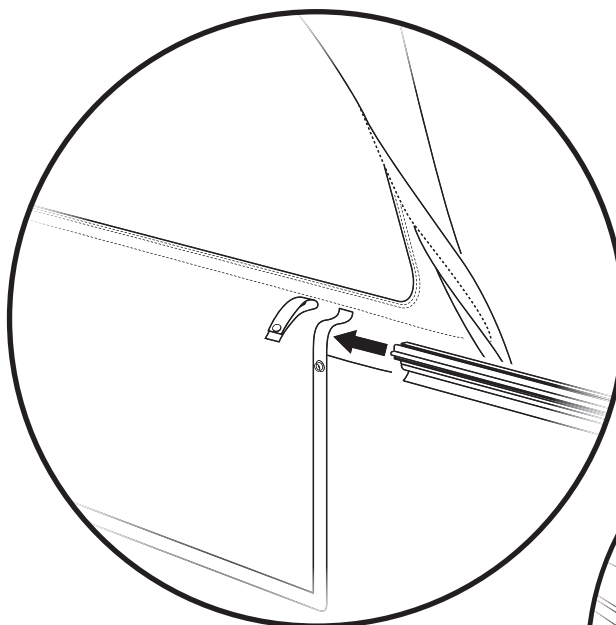

Slide the front rail onto the plastic retainer at the bottom of the front window.  
The rail should go under the large flap.  
See Detail.

Detail

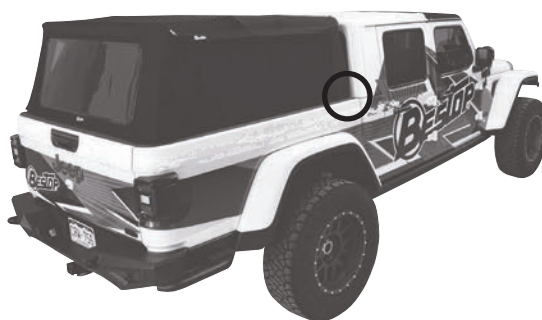
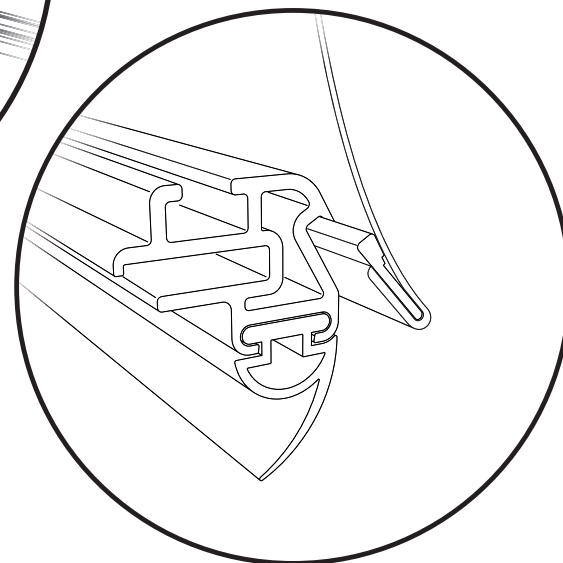



## Section 12 Tuck Plastic Tabs into Rails

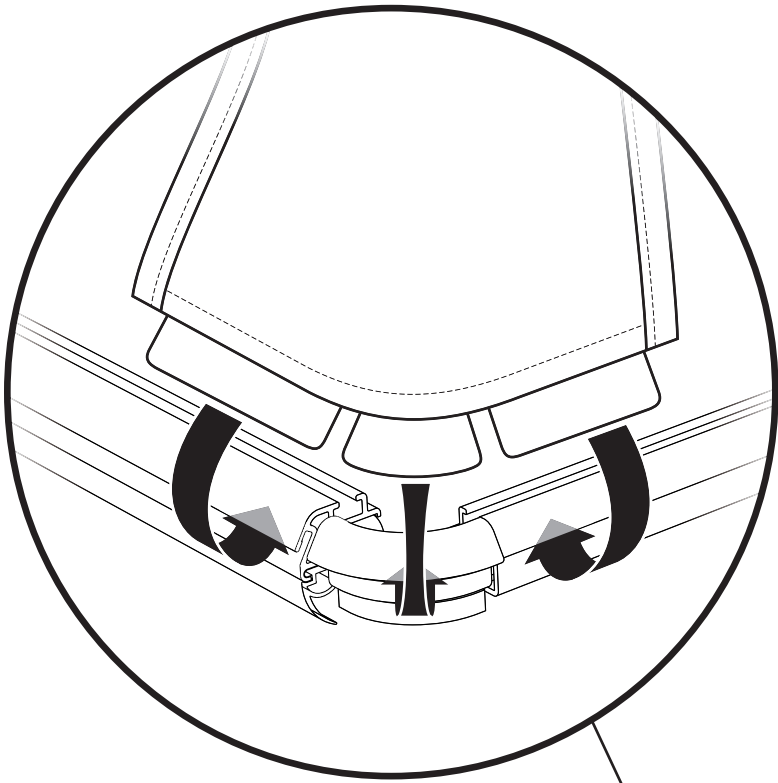

Tuck the plastic tabs at the bottom of each corner of the top into the slots in the Side Rails and Front and Rear Rails.



## Section 13 Opening and Storing the Top

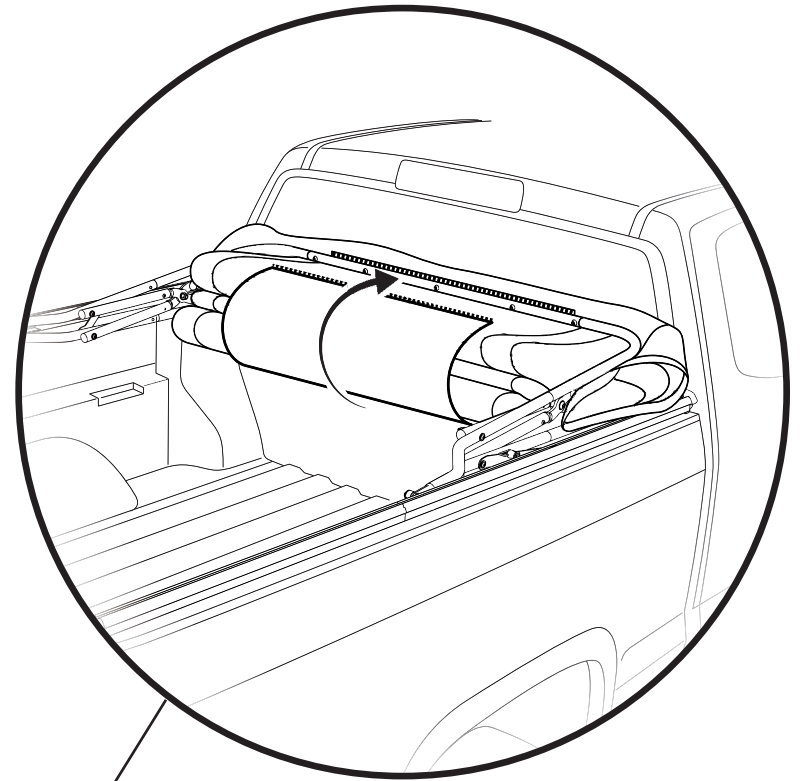
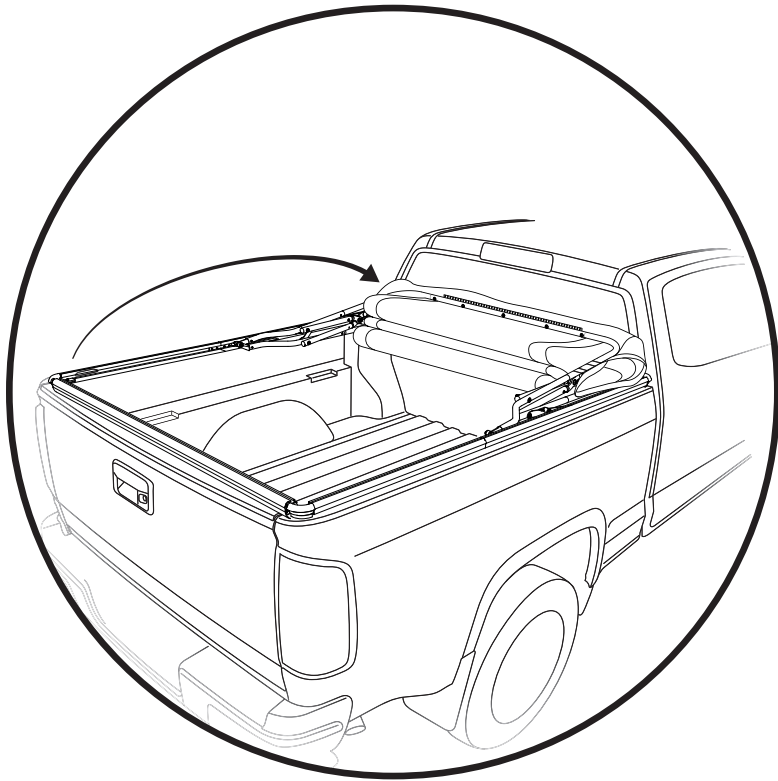

To open the top:

Unzip and remove Side Curtains.

Unzip and remove Rear Window.

Release plastic tabs from rails all around.

Flip rear corners of top fabric up onto roof.

Fold the top forward so that all the bows collapse and rest on the Front Rail.

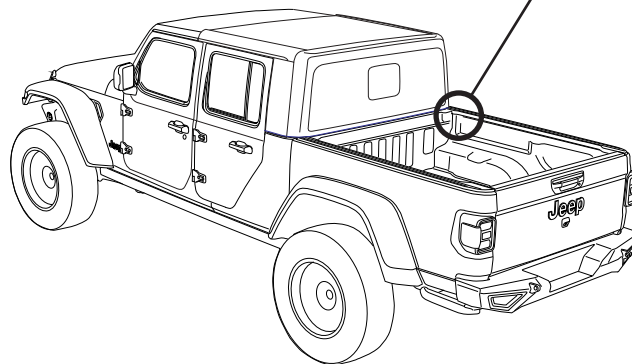

Protect the top fabric by wrapping the Boot attached to the Front Window around the Fabric and Bows.

Secure the Boot by zipping it to the zipper for the Rear Window.

## Section 14 Store Rear Rail When Top is Folded Down

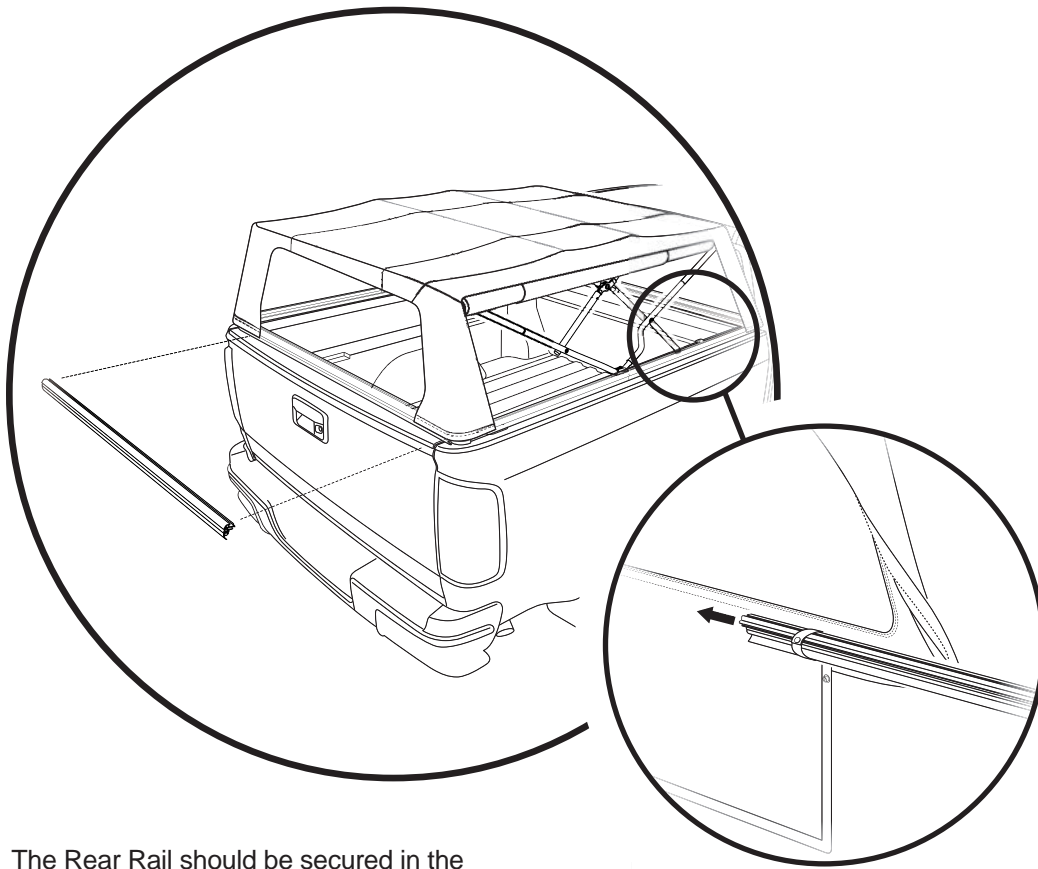

The Rear Rail should be secured in the straps at the bottom of the Front Window when the top is folded down.

Wrap the straps around the Rear Rail and snap closed.



## Section 14 Storing the Rear Window; Rolling Up Side Curtains

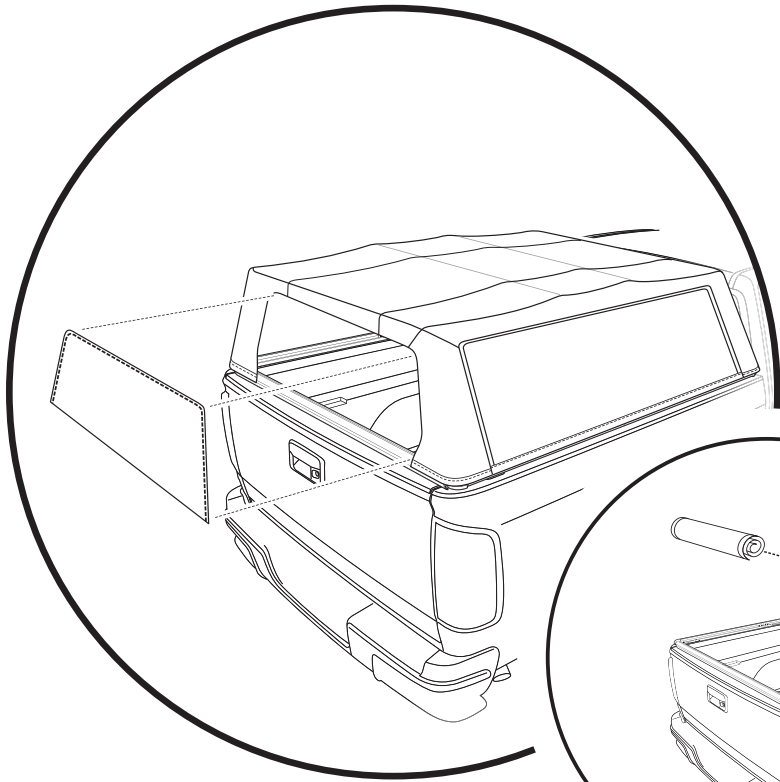

With the Fabric Top up, the Rear Window can be stored in the Boot attached to the bottom of the Front Window.

Place the rolled-up Rear Window in the Boot, and zip the Boot closed.

**Note:** Windows should be clean to prevent scratching.

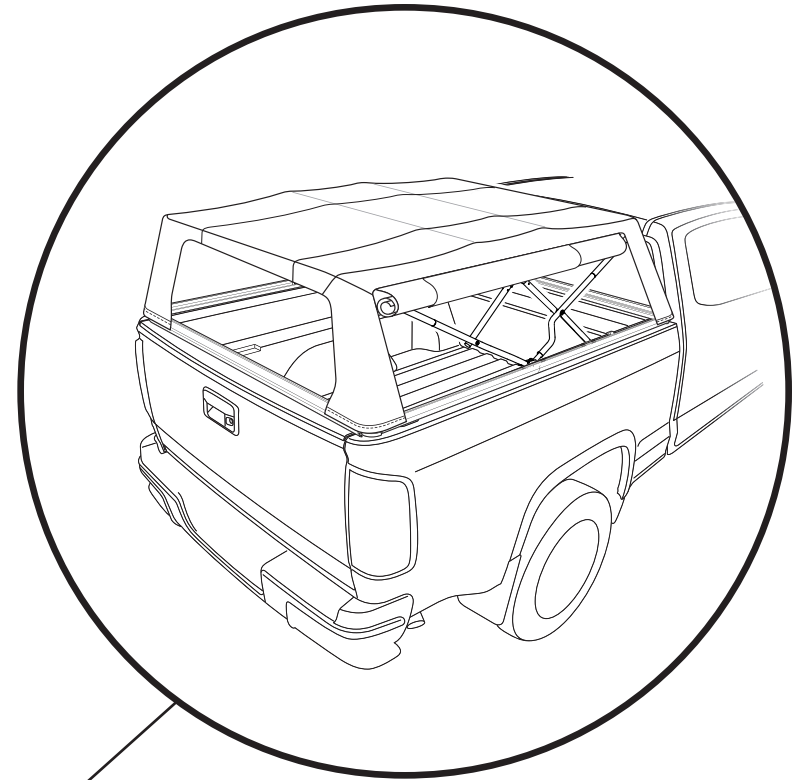
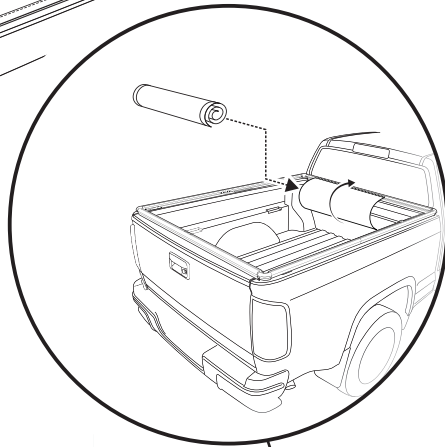

With the Fabric Top up, the Side Curtains can be rolled up and secured with attached side flaps.

