



# Installation Instructions Supertop for Trucks

Vehicle Application:  
Nissan Titan 6.5' Bed w & w/o Utili-Track system  
Part Number 77313

## Installation Tips

Before you begin installing your new Supertop, please read all the instructions thoroughly.

It is recommended that two people install this Bestop product.

For a smooth fit:

For easier installation, the top should be installed at a temperature above 72° F. Below this temperature, the fabric may contract an inch or more, making it difficult to fit the vehicle. You may let the fabric sit in the sun for 15-20 minutes before installing to let the fabric warm up.

It is normal for the fabric to contract and wrinkle when stored in the shipping carton. Within a few days after installation, the fabric will relax and the wrinkles will disappear.











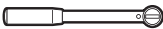

**WARNING** Do not rely in any way on the components of this product to protect against injury or death in the event of an accident. Never operate the vehicle in excess of manufacturer's specifications.

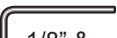
Read and follow, precisely, all installation instructions provided when installing this product. Failure to do so may result in a poor fit and could place occupants of the vehicle in a potentially dangerous situation.

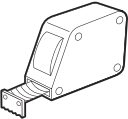
**CAUTION** Safety glasses should be worn at all times when installing this product.

**WEAR SEAT BELTS AT ALL TIMES**

Tools			
 Ratchet	 9/16" Socket	- OR -	 9/16" Wrench
 Safety Glasses	 1/8" & 1/4" Allen Wrench	 Utility Knife	 Tape Measure
 Pliers	 Wire Ties (Not included)	 Phillips Screwdriver	

Installation Time
 2 hours
Skill Level
<div style="display: flex; justify-content: space-around; align-items: center;"> <span style="border: 1px solid black; border-radius: 50%; padding: 5px;">1</span> <span style="border: 1px solid black; border-radius: 50%; padding: 5px;">2</span> <span style="border: 2px solid black; border-radius: 50%; padding: 5px;">3</span> <span style="border: 1px solid black; border-radius: 50%; padding: 5px;">4</span> </div> <p>3 - Moderately Difficult</p>







# Installation Instructions Supertop for Trucks

Vehicle Application:  
Nissan Titan 6.5' Bed w & w/o Utili-Track system  
Part Number 77313

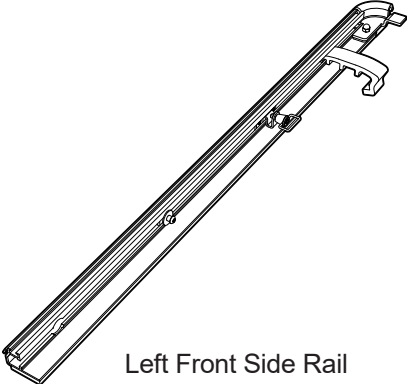
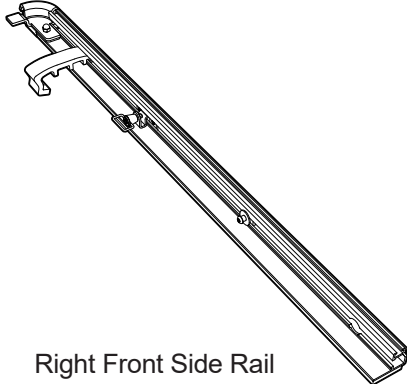
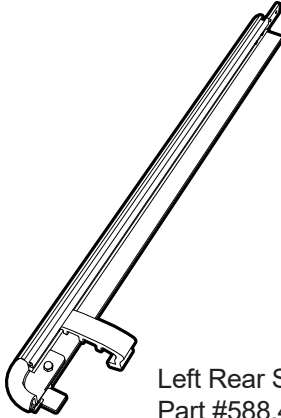
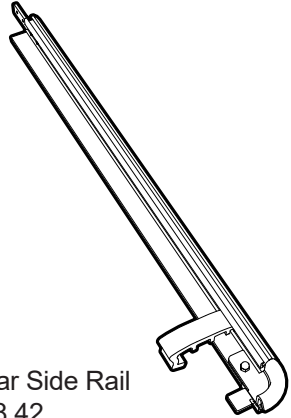
## Parts List

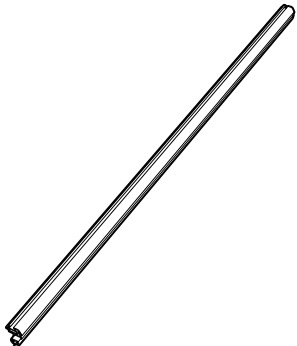
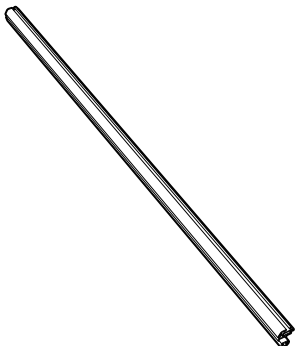
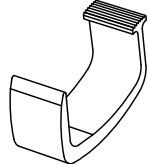
- Required parts for installation - Page number in Installation Guide

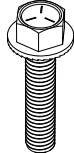
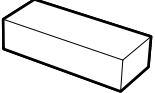
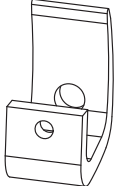
Sections 1 & 2		Side Rails		Pages 5 to 7 of Guide	
					
Left Front Side Rail Part #585.21 Qty. 1	Right Front Side Rail Part #585.20 Qty. 1	Left Rear Side Rail Part #588.41 Qty. 1	Right Rear Side Rail Part #588.42 Qty. 1		

Sections 2 to 4		Hardware, Front and Rear Rails		Pages 6 to 9 of Guide	
					
Front Rail Part #588.44 Qty. 1	Rear Rail Part #588.43 Qty. 1	Lower Clamp Part #579.23 Qty. 4	Track Block Part #602.02 Qty. 4	Hex Head Bolt Part #581.75 Qty. 4	Rubber Pad Part #720035 Qty. 8
					
		Lower Clamp Part #582.07 Qty. 4	Set Screw Part #573.17 Qty. 4	5/16-18 Socket Cap Screw Part#581.76 Qty. 4	

Step 1

Hardware

Step 2

573.17

585.21

585.20

588.41

588.42

 Set Screw  
Part #573.17  
Qty. 4

Front Side Rail  
Part #585.21 - Left (shown)  
Part #585.20 - Right  
Qty. 1 of each

Rear Side Rail  
Part #588.41 - Left (shown)  
Part #588.42 - Right  
Qty. 1 of each

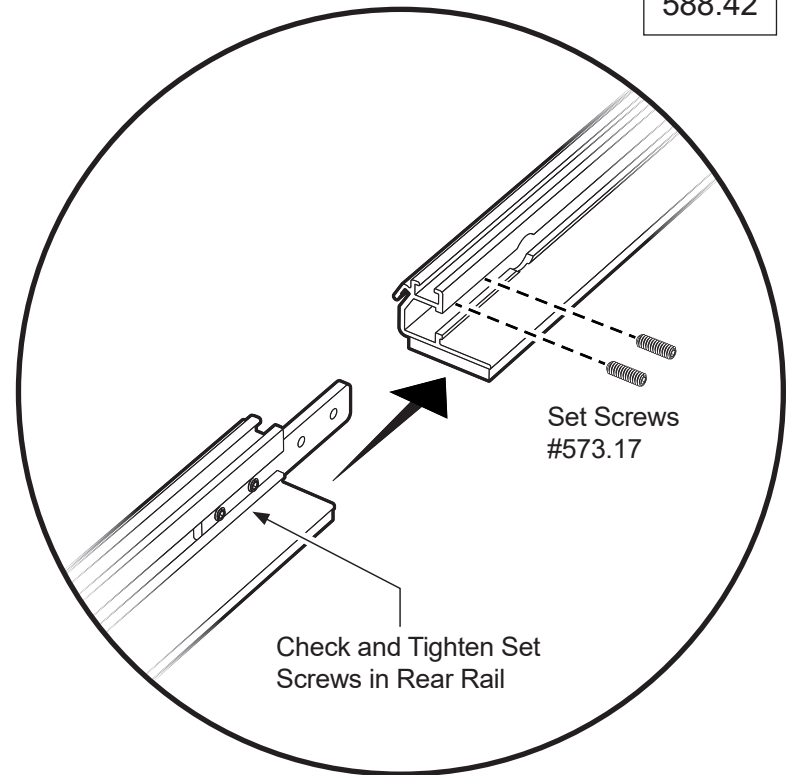
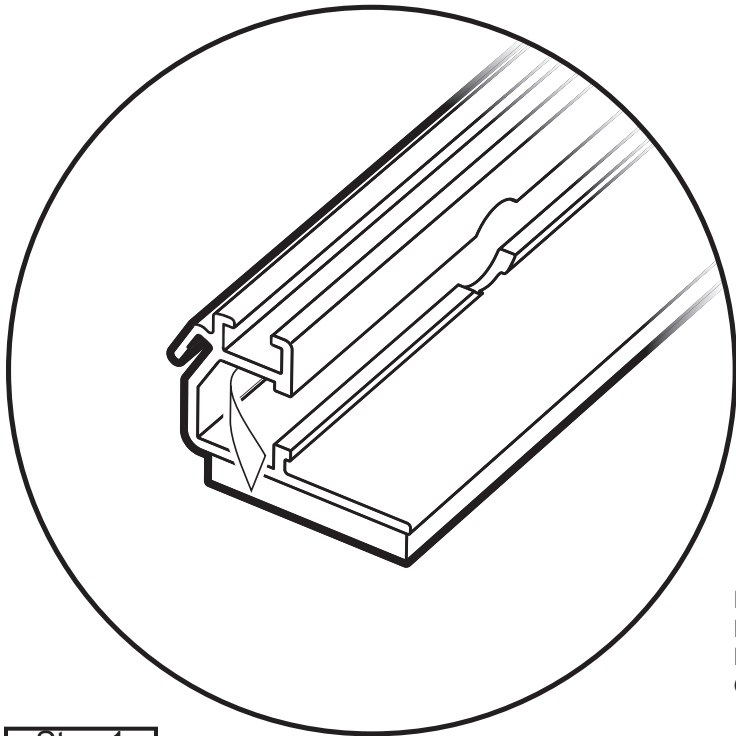

Step 1

Locate the Foam Tape on the Left and Right Side Rails, and remove the paper backing from the foam tape.

Repeat with the both Side Rails.

Step 2

Assemble the Left Front Side Rail #585.21 and the Left Rear Side Rail #588.41.

Slide the rails together, and secure using two set screws #573.17.

Check and tighten the two (2) set screws in the rear rail.

Repeat with the Right Side Rails.

Tools



1/8" Allen Wrench

Step 1 588.44 588.43

Hardware

Step 2 Side Rail Assemblies

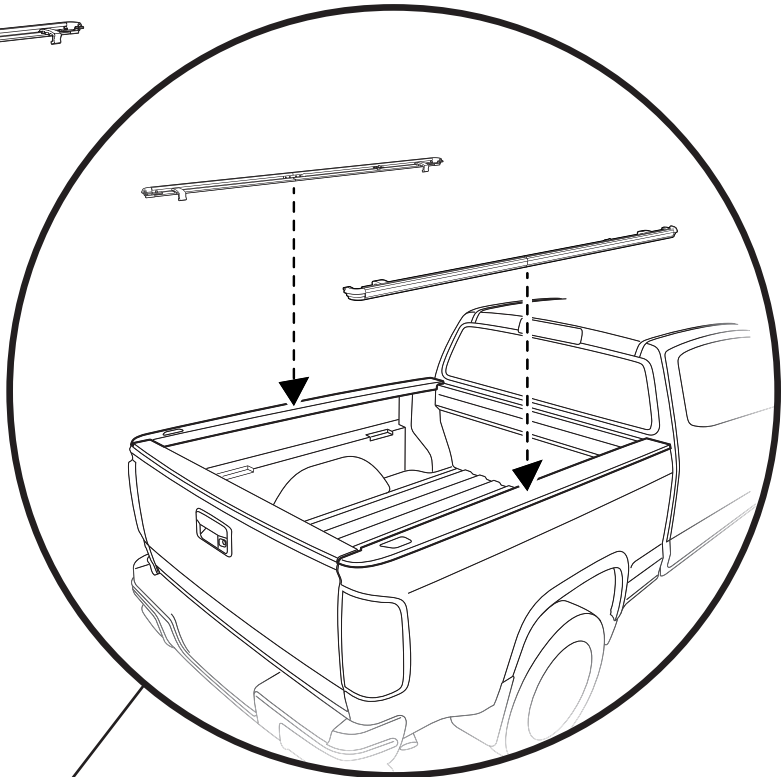
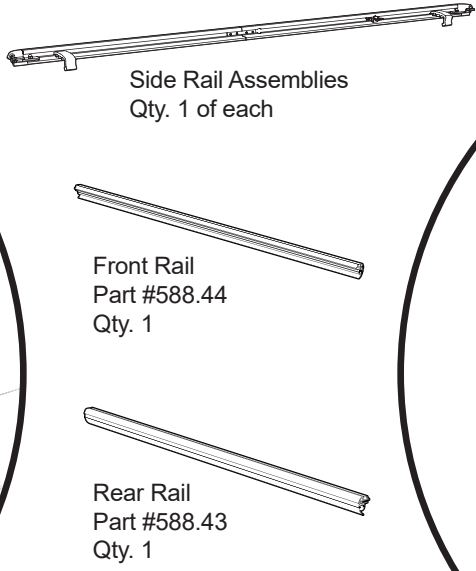
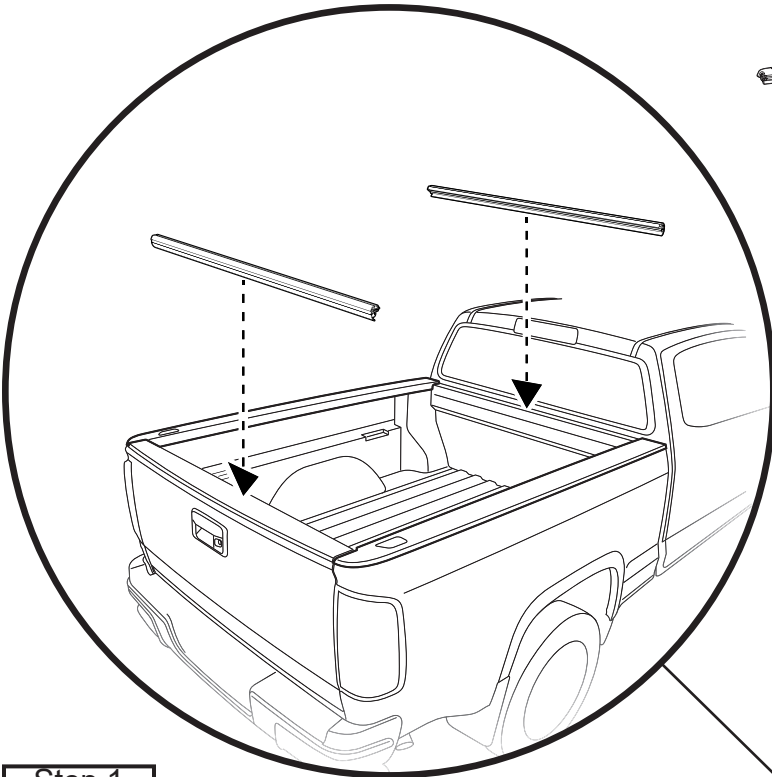

Step 1

Place the Front Rail #588.44 and Rear Rail #588.43 onto the truck bed.

Lay the Rails on top of the truck bed in front, and on top of the plastic bed protector at the rear.

**NOTE:** The Front Rail is longer than the Rear Rail.

Step 2

Place Side Rail assemblies onto the truck bed. Lay the Rails on top of the plastic bed protectors.

Attach the Side Rails to the Front and Rear Rails.

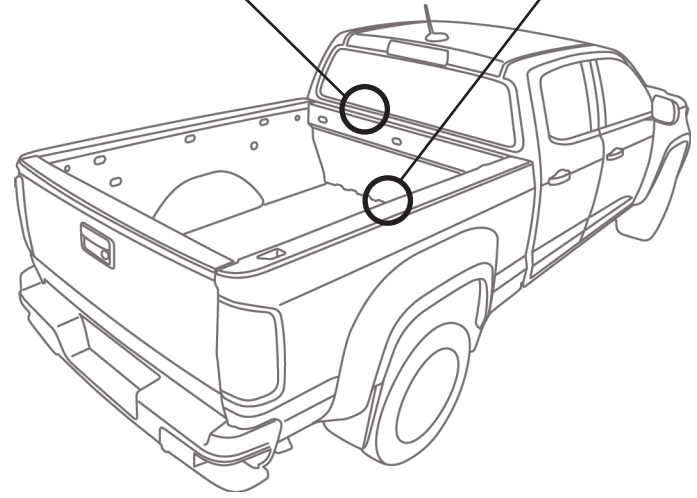

Step 1

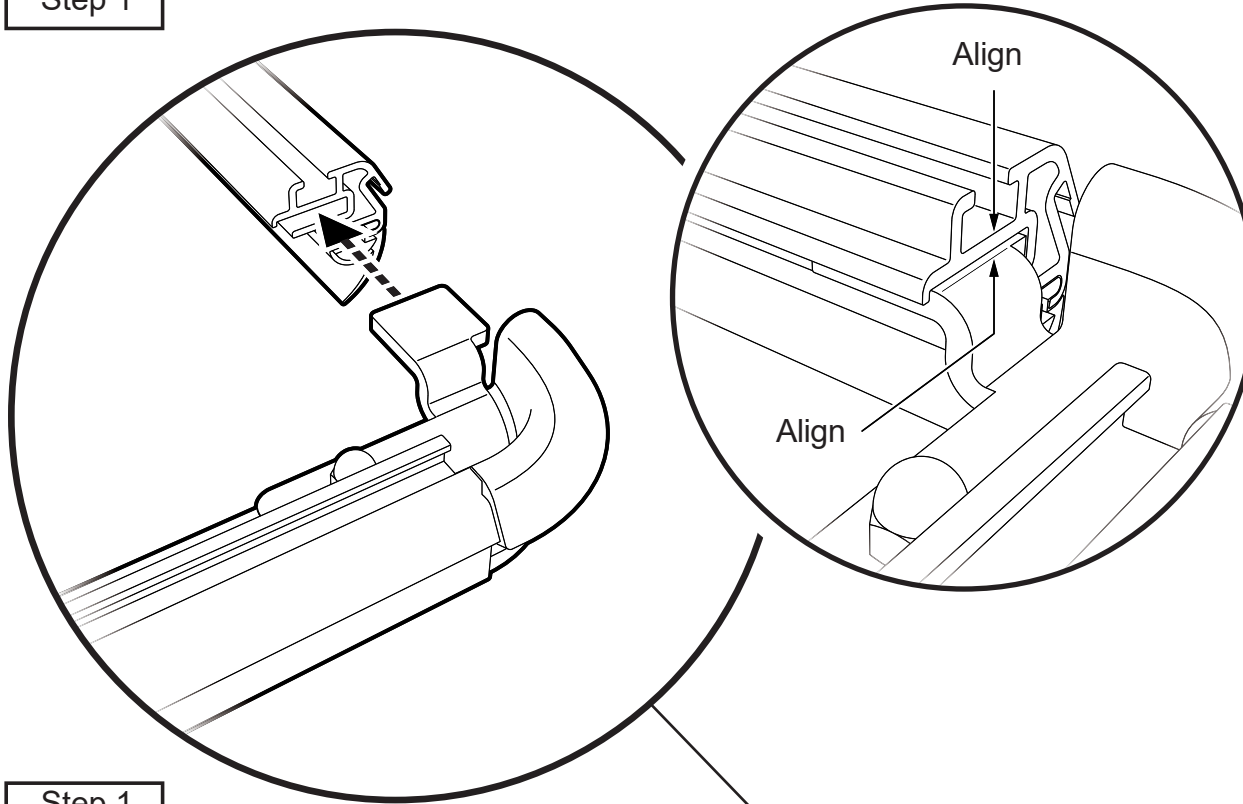

Step 1

Attach the Front and Rear Rails to the Side Rail Assemblies.

Slide the tabs at the front and rear of the Side Rail Assemblies into the slots in the Front and Rear Rails.

Make sure that the ends of the Front Rail and Rear Rail extrusions are aligned with the tongue of the attachment feature, where the tongue bends, and the small corner protrudes.

Step 2

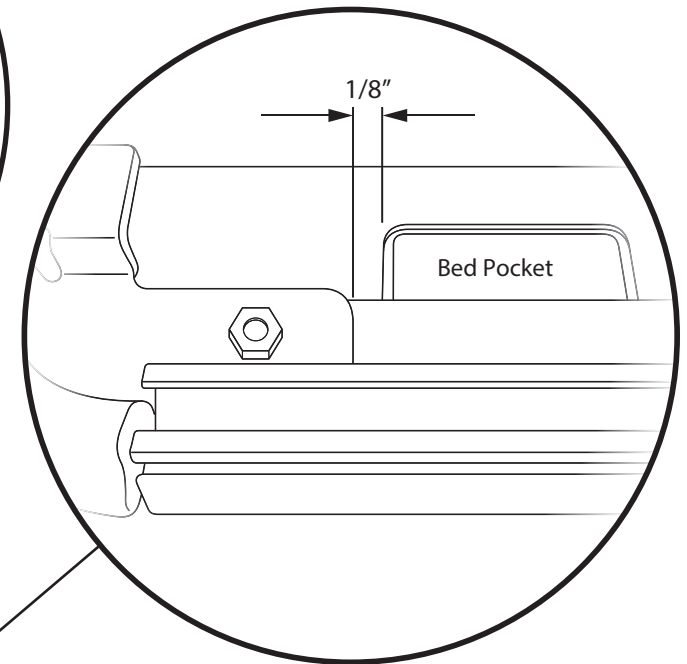

Step 2

Align the edge of the flanges at the rear of each Side Rail Assembly 1/8" behind the Bed Pocket in the top of the plastic bed protector, as shown in the diagram above.

Align the Side Rails on both sides of the vehicle.

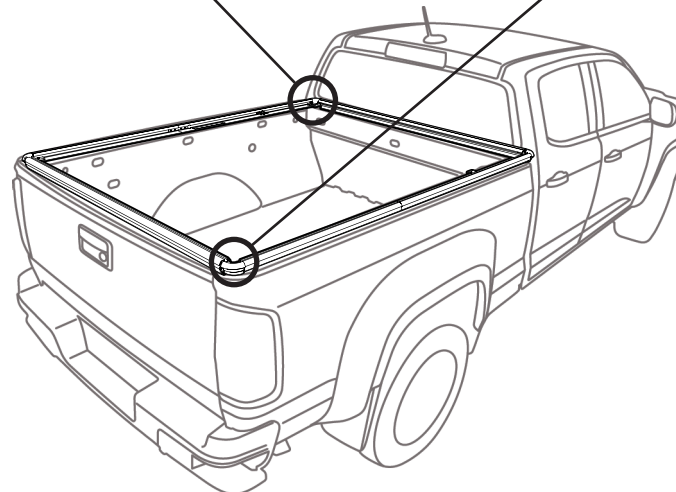

Step 1 Rail Assembly

Hardware

Step 2 720035

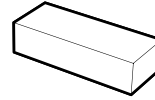

Rubber Pad  
Part #720035  
Qty. 4



Step 1

Adjust the Side and Front and Rear Rail assembly right-to-left to center it on the bed width.

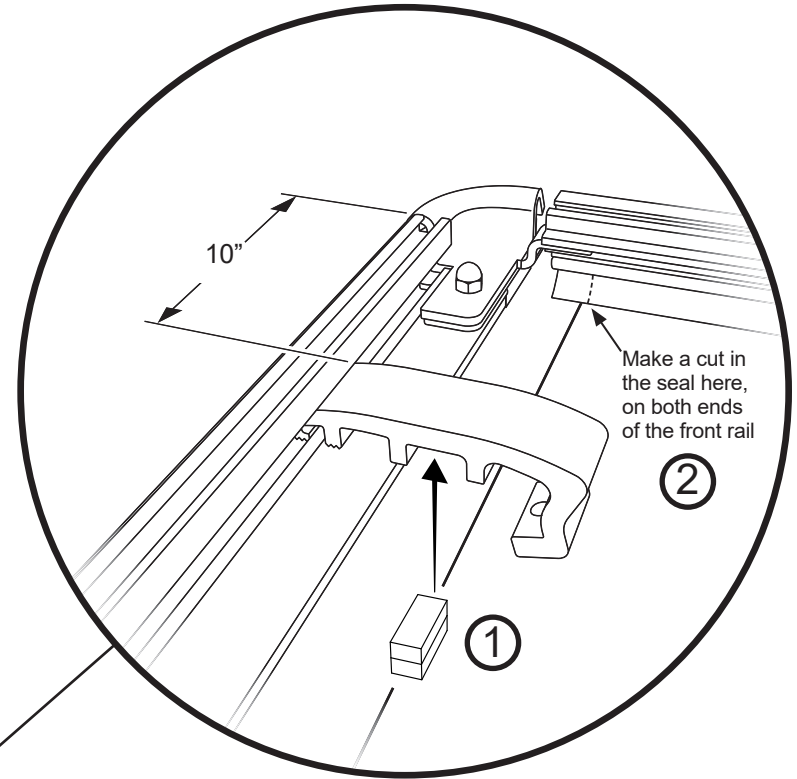

Step 2

① Attach two (2) Rubber Pads #720035 together, and stick them to the Front Rail Clamp, between the rib farthest from the rail, and the next rib.

The rubber pads must rest on top of the bed rail cap after installation.

Front Clamp should be located 10" from the end of the Front Side Rail.

② Make two cuts in the seal on the bottom of the front rail, in line with the inner edge of the bed rail cap, so that the seal will lay flat against the bed bulkhead.

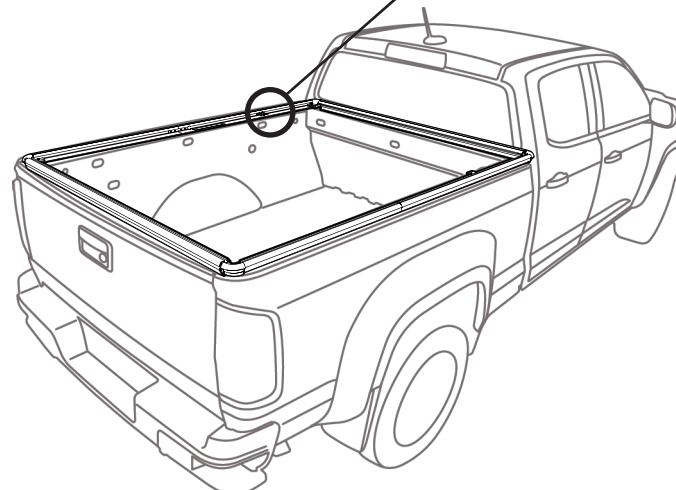

Step 1 720035

Hardware

Step 2 579.23 581.75

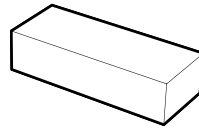
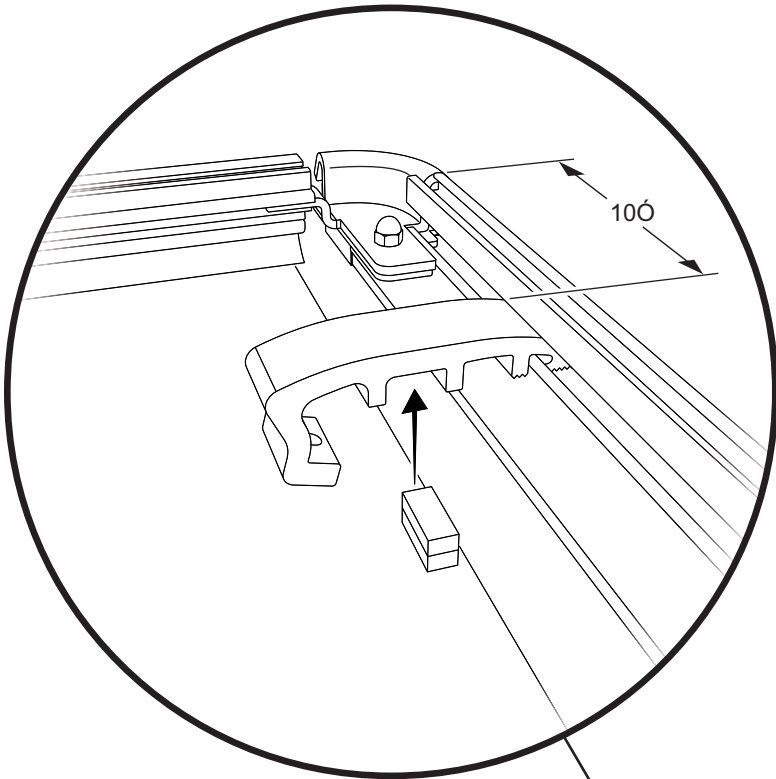

Rubber Pad  
Part #720035  
Qty. 4

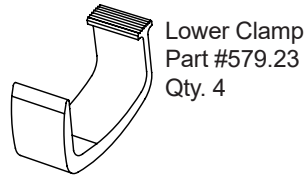

Lower Clamp  
Part #579.23  
Qty. 4

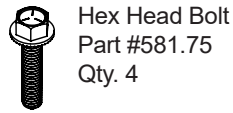

Hex Head Bolt  
Part #581.75  
Qty. 4

**NOTE: IF YOU HAVE THE UTILI-TRAC, SKIP STEP 2 AND GO TO PAGE'S 10 & 11.**

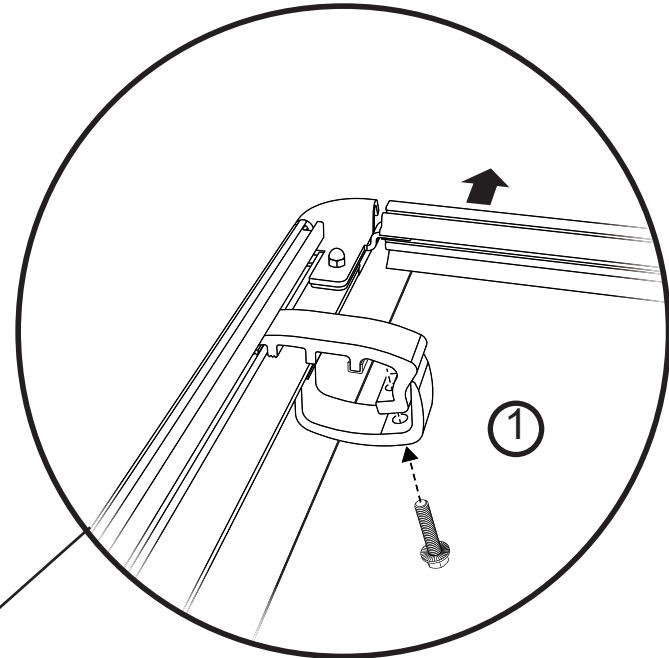

Step 1

Attach two (2) Rubber Pads #720035 together, and stick them to the Rear Rail Clamp, between the rib farthest from the rail, and the next rib.

The rubber pads must rest on top of the bed rail cap after installation.

Rear Clamp should be located 10" from the end of the Rear Side Rail.

**NOTE:** Make sure that the Rubber Pads are lined up on top of the vehicle's bed rail cap.

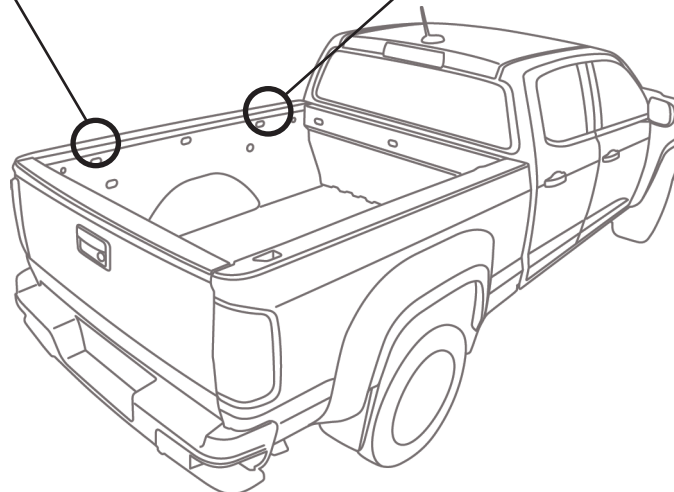

Step 2

① Attach Lower Clamps #579.23 to the pre-assembled Upper Clamps on the Side Rails, using one (1) Hex Head Bolt #578.39 for each clamp.

Check alignment of the Rail Assembly and tighten all bolts.

Step 1	529.83	529.84
--------	--------	--------

Tools
-------

Hardware
----------

Step 2	582.07	602.02	581.75	581.76
--------	--------	--------	--------	--------

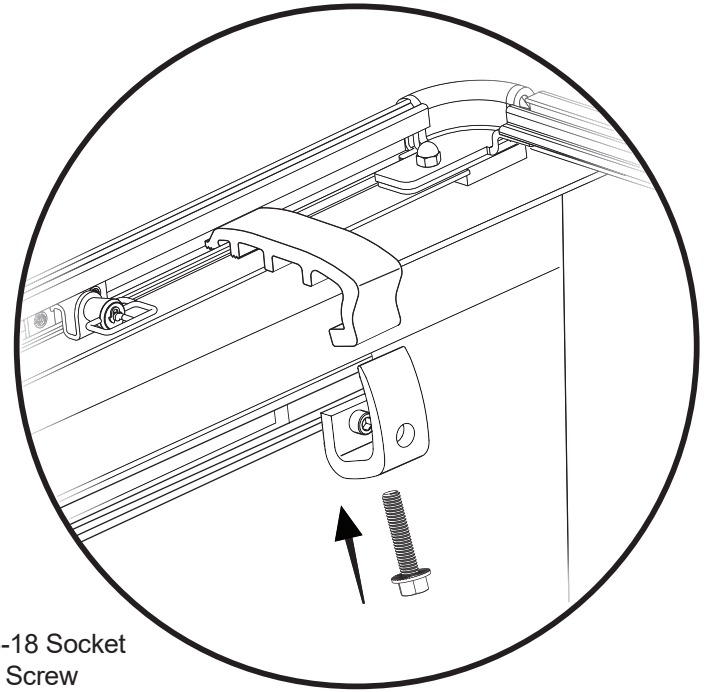
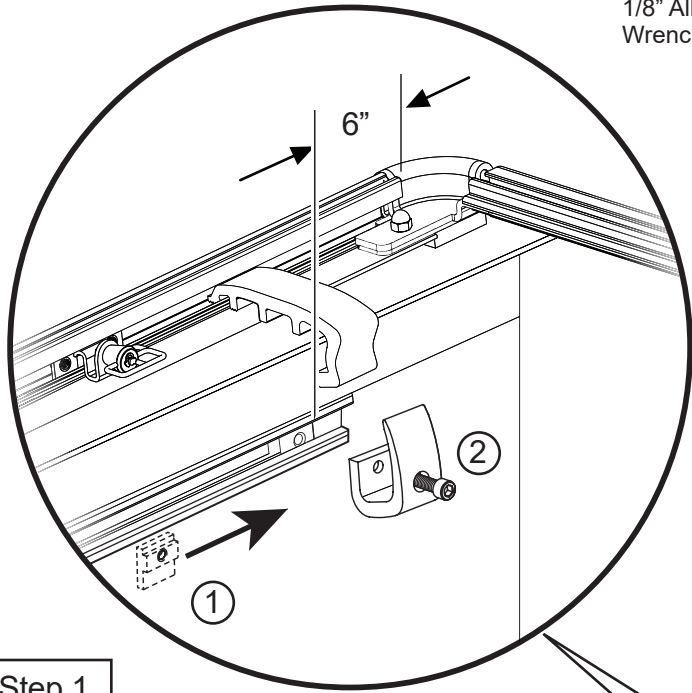
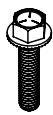
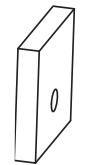
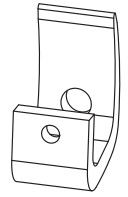

**Step 1**

① From rear of vehicle slide track block 602.02 down the Utili-track to the front of the vehicle.

The Track Block should be located 6" from the end of the Front Side Rail.

**Make sure the Track Block is oriented so that the threaded hole is on top.**

② Attach the Lower Clamp #582.07 to the Track Block using the 1.0" Socket Bolt #581.76. Tighten by hand.

Complete the same steps on the opposite side of the vehicle.

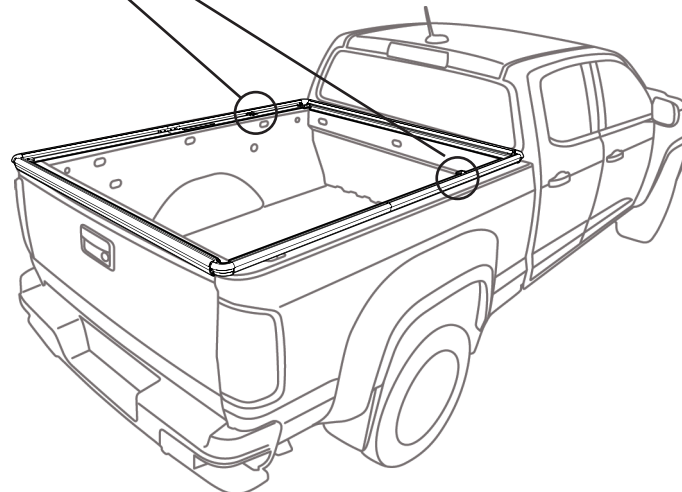

**Step 2**

Align the Pre-installed Upper Clamp to the Lower Clamp #582.07, using Hex Bolt #581.75 to tighten the two Clamps together.

Complete the same steps on the opposite side of the vehicle.

**NOTE:** Lower Clamp may need to be moved either forward or rearward to make installation of the upper clamp easier.



Step 1	529.83	529.84
--------	--------	--------

Tools	Hardware
-------	----------

Step 2	582.07	602.02	581.75	581.76
--------	--------	--------	--------	--------

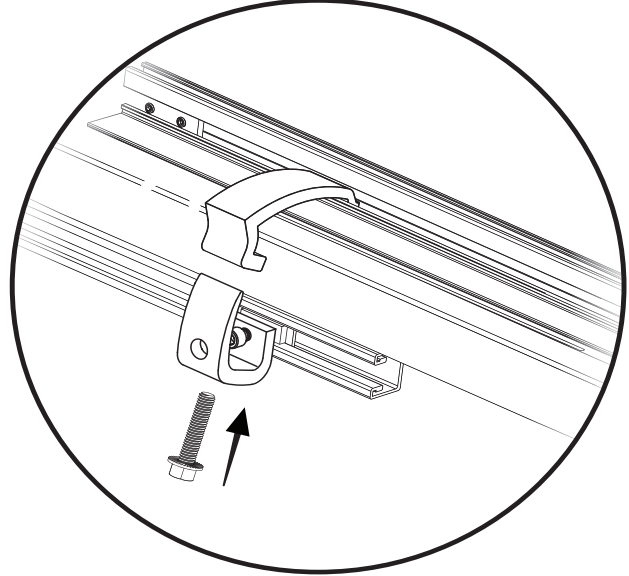
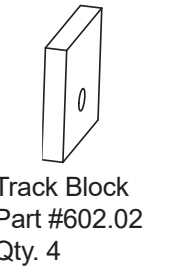
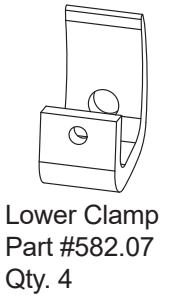
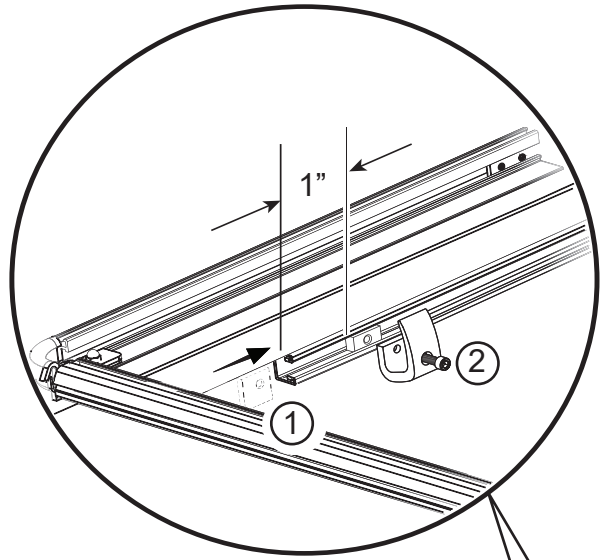

**Step 1**

① From rear of vehicle slide track block 602.02 down the Utili-track.

The Track Block should be located 1" from the end of the Side Rail.

**Make sure the Track Block is oriented so that the threaded hole is on top.**

② Attach the Lower Clamp #582.07 to the Track Block using the 1.0" Socket Bolt #581.76. Tighten by hand.

Complete the same steps on the opposite side of the vehicle.

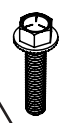

**Step 2**

Align the Pre-installed Upper Clamp to the Lower Clamp #582.07, using Hex Bolt #581.75 to tighten the two Clamps together.

Complete the same steps on the opposite side of the vehicle.

**NOTE:** Lower Clamp may need to be moved either forward or rearward to make installation of the upper clamp easier.

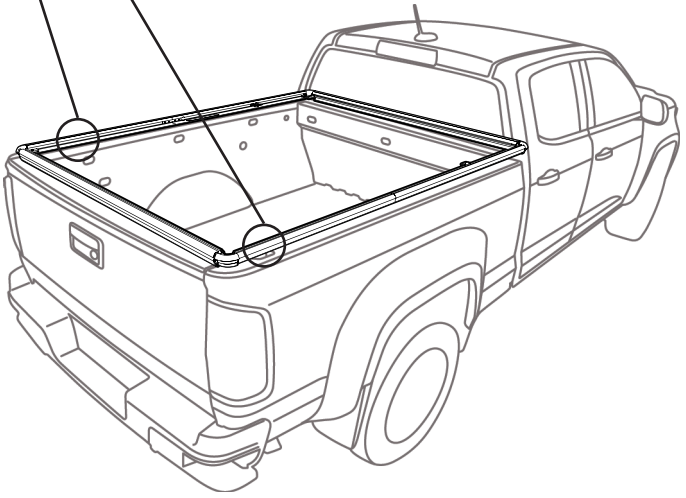

Step 1	573.77	573.79	579.38
--------	--------	--------	--------

Hardware

579.38	579.39
--------	--------

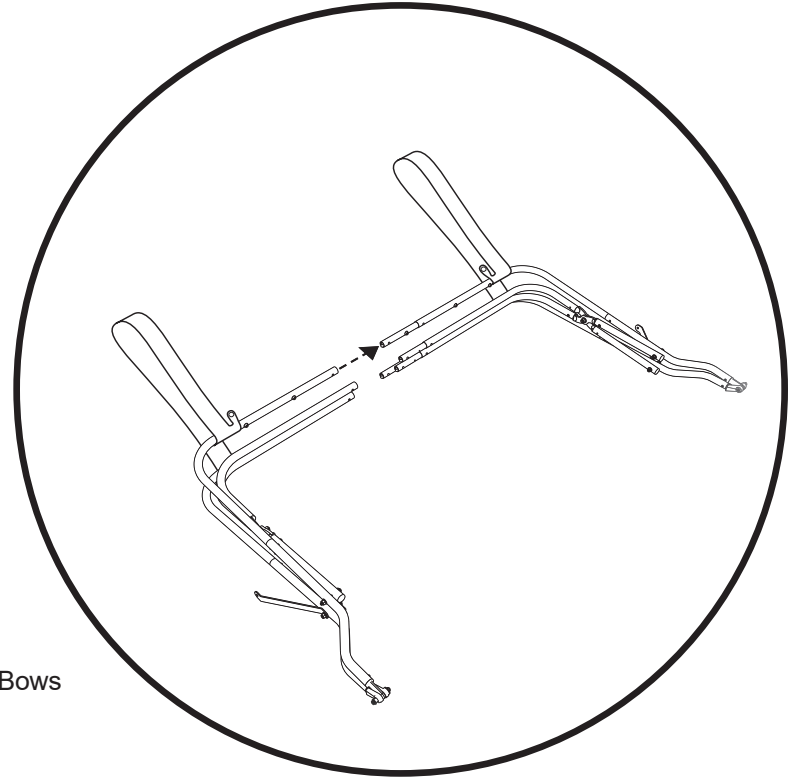
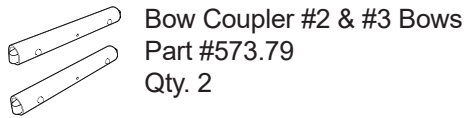
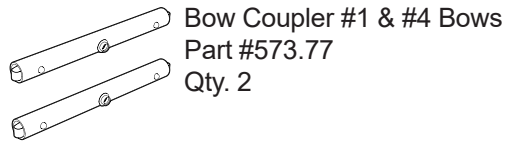
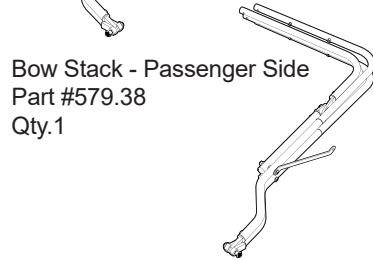
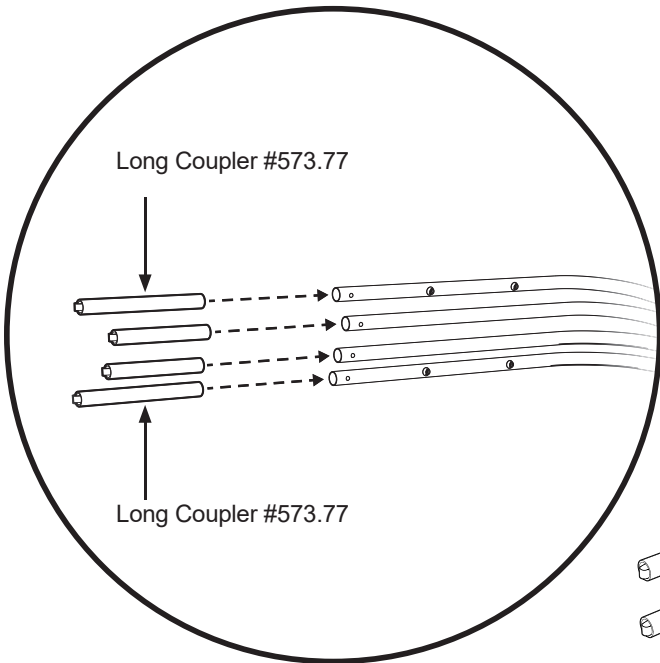

Step 1

Attach Bow Couplers #573.77 and #573.79 to the Passenger Side Bow Stack #579.38.

Insert Long Couplers #573.77 into the outer bows #1 and #4.

Insert Short Couplers #573.79 into the inner bows #2 and #3.

**For Easier Installation:**

Slide all bows and couplers together before snapping the spring clips into the holes in the bows.

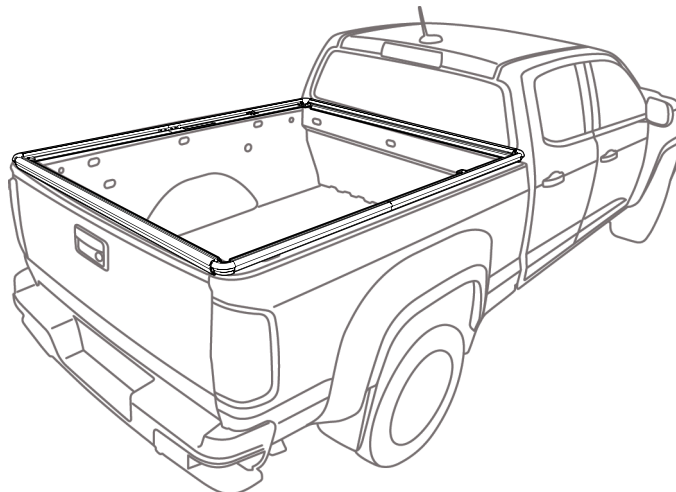

Step 2

Attach Driver Side Bow Stack #579.39 to Passenger Side Bow Stack #579.38.

Bow Stacks attach using the Couplers installed in Step 1.

Slide the Couplers installed in the Passenger Side Bow Stack into the ends of the bows on the Drivers Side Bow Stack.

Before attaching couplers to bow stacks, make sure to pull the bond coat straps out and away from the bows, and lay them flat.

Step 1 Bow Assembly

Details

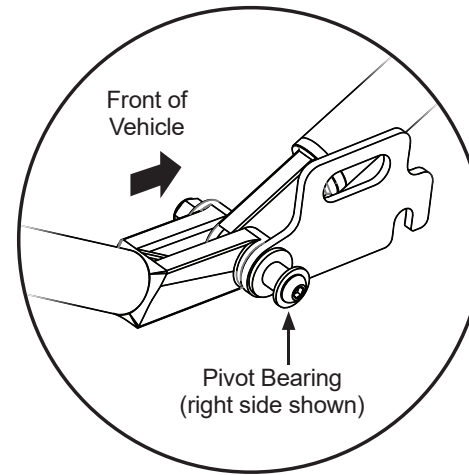
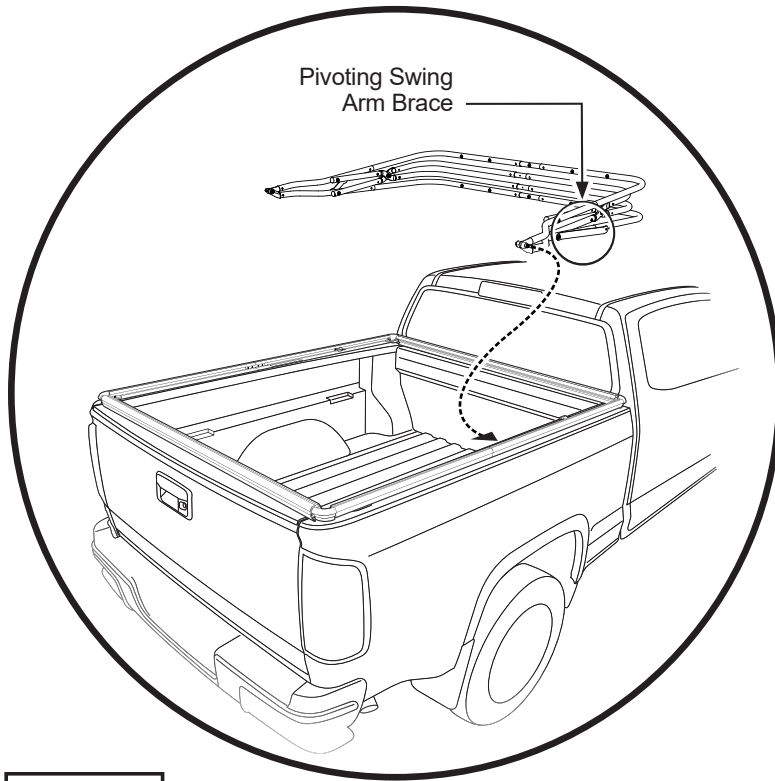

Details

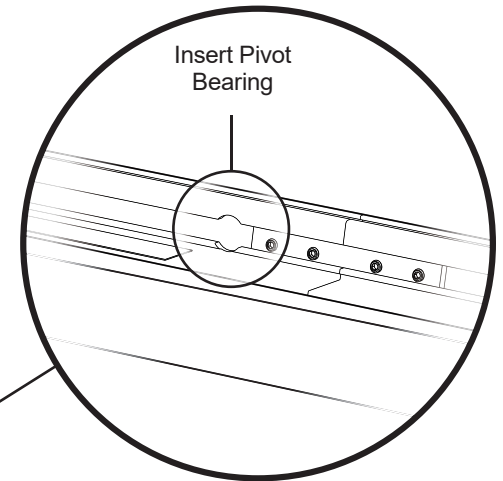

Step 1

**NOTE:** Two People Are Required for This Portion of the Installation Process.

Place the folded Bow Assembly on the Side Rails. Make sure that the pivot swing arm braces are on the lowest bow.

Insert the Pivot Bearings into the receiving holes in the inside of the side rails

See Details.

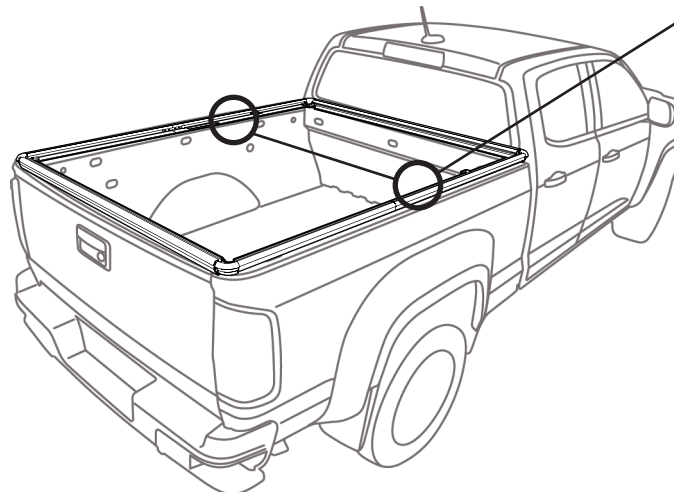

Step 1

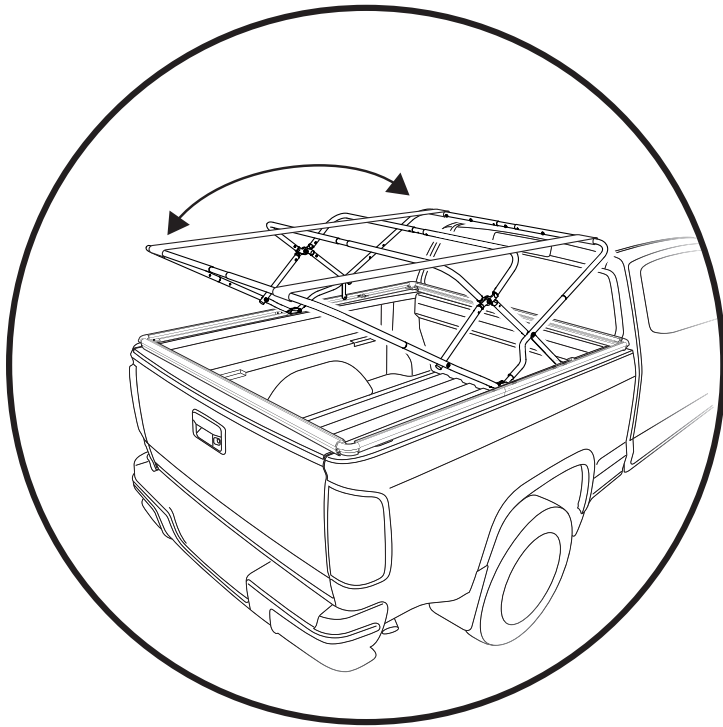

Step 2

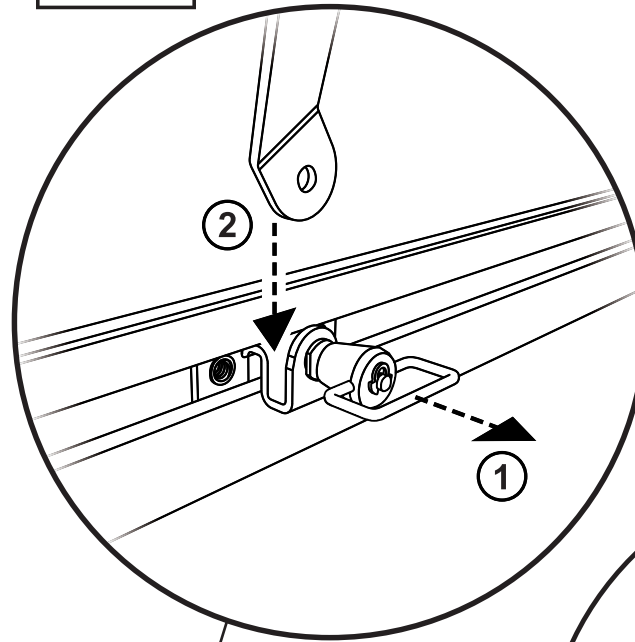

Step 3

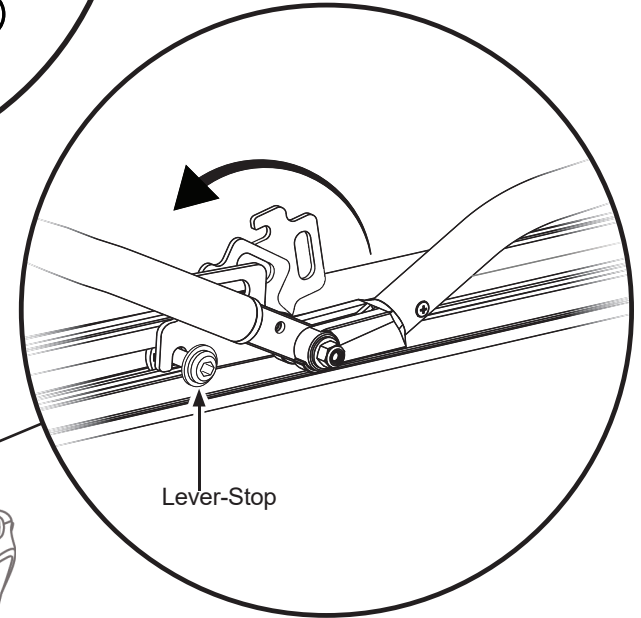

Step 1

Unfold the Bow Assembly.

Step 2

① Pull back on the Pivot Knuckle release knob;

② Snap the Pivot Arm Brace into place, on both sides of the truck.

Step 3

Engage the Locking Lever on both sides of the truck.

**NOTE:** The Lever-Stop Assemblies are pre-installed at the factory at 31.5" from the front edge of each Side Rail.

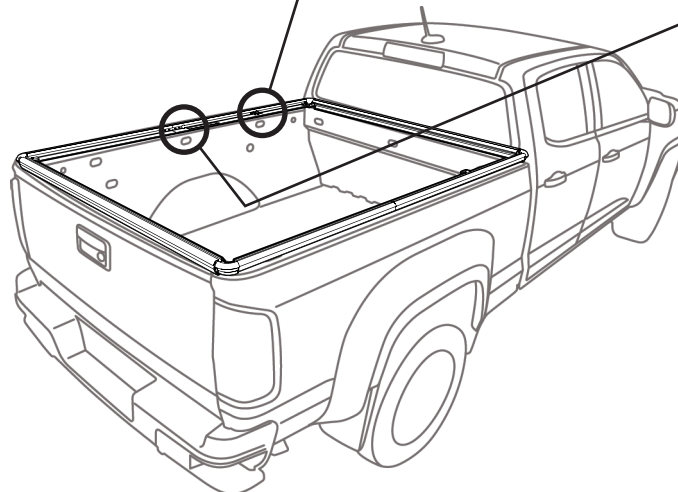

Step 1

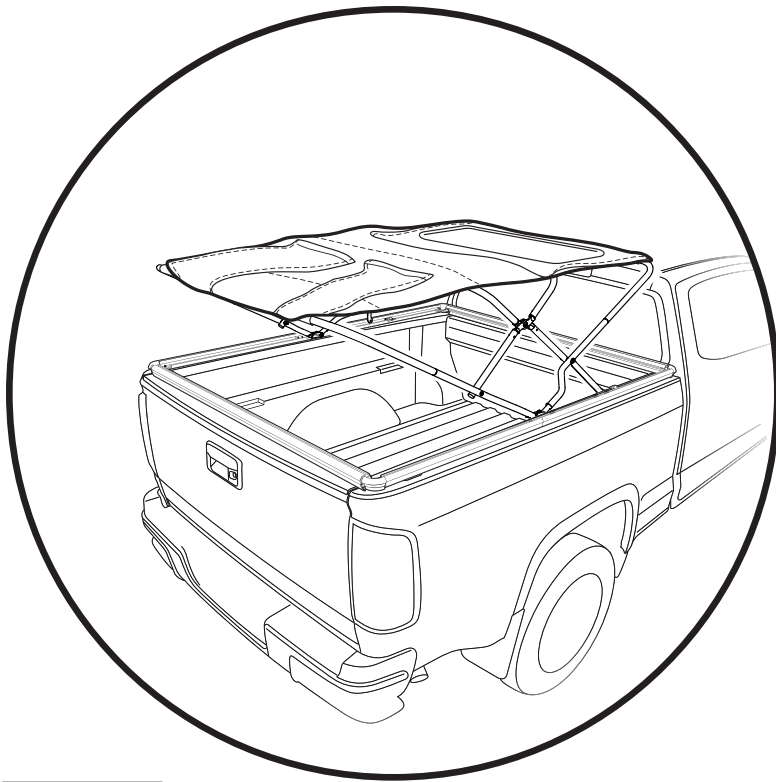

Step 2

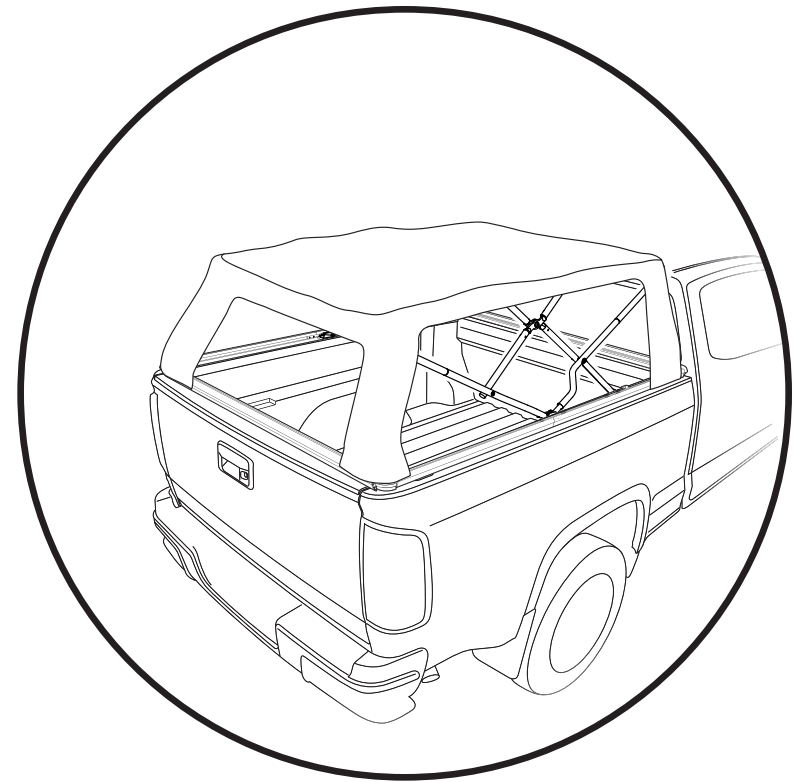

Step 1

Place the folded Soft Top onto the unfolded Bow Assembly.

Step 2

Unfold the front and back of the Top over the #1 and #4 Bows.

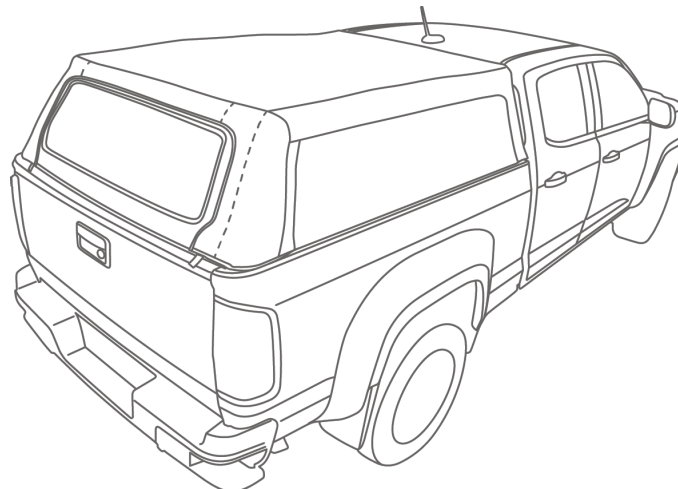

Step 1

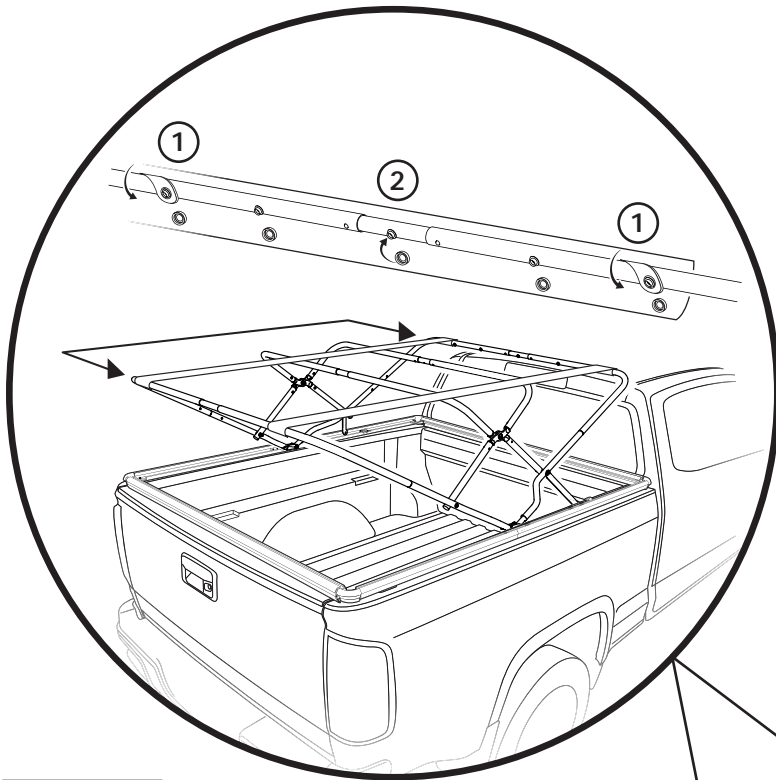

Step 1

From inside the truck bed:

① Wrap the small flaps with holes over the outer-most snaps on the #1 bow (Bow closest to the truck cab).

② Wrap the fabric flap around the #1 Bow and snap all five snaps to secure the fabric to the Bow.

**NOTE:** Secure the outer snaps before securing the center snaps.

Repeat for the #4 Bow (Bow closest to the truck tailgate).

Step 2

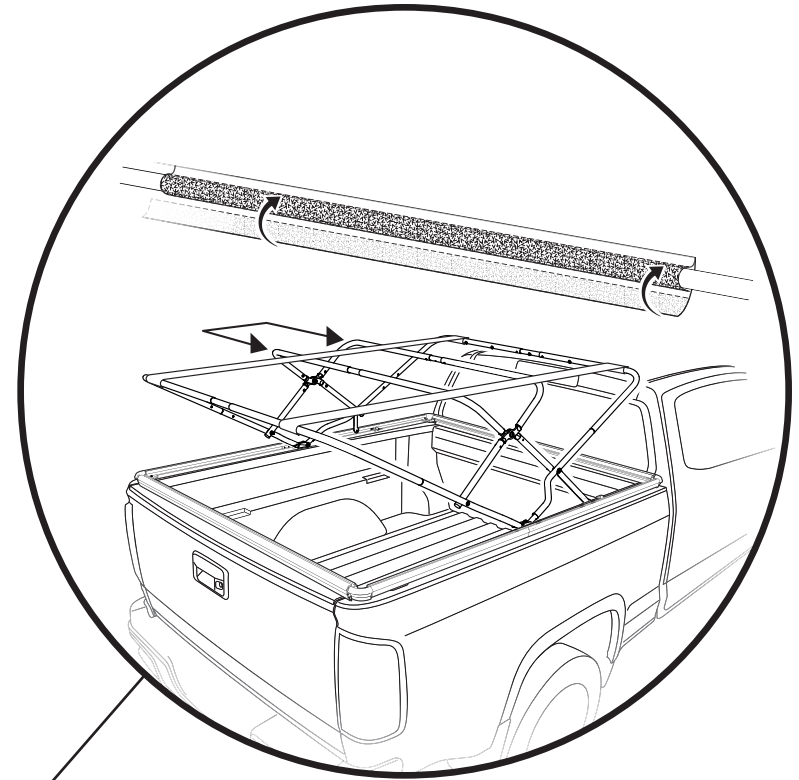

Step 2

From inside the truck bed:

Wrap the fabric flaps with hook-and-loop around the #2 and #3 bows (the two middle bows) to secure the top fabric to these Bows.

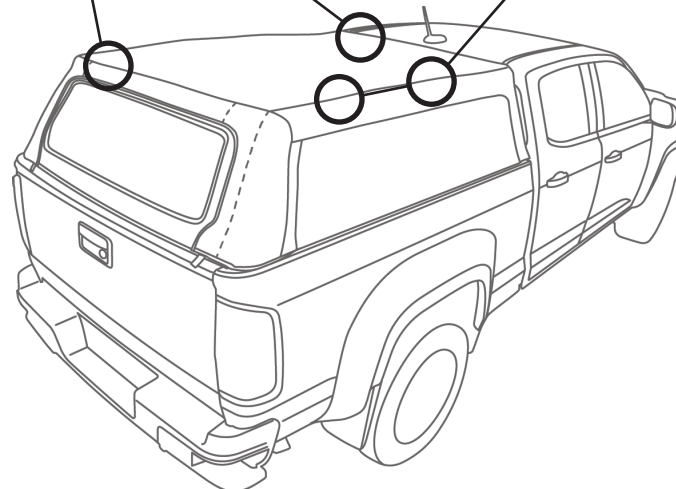

Step 1

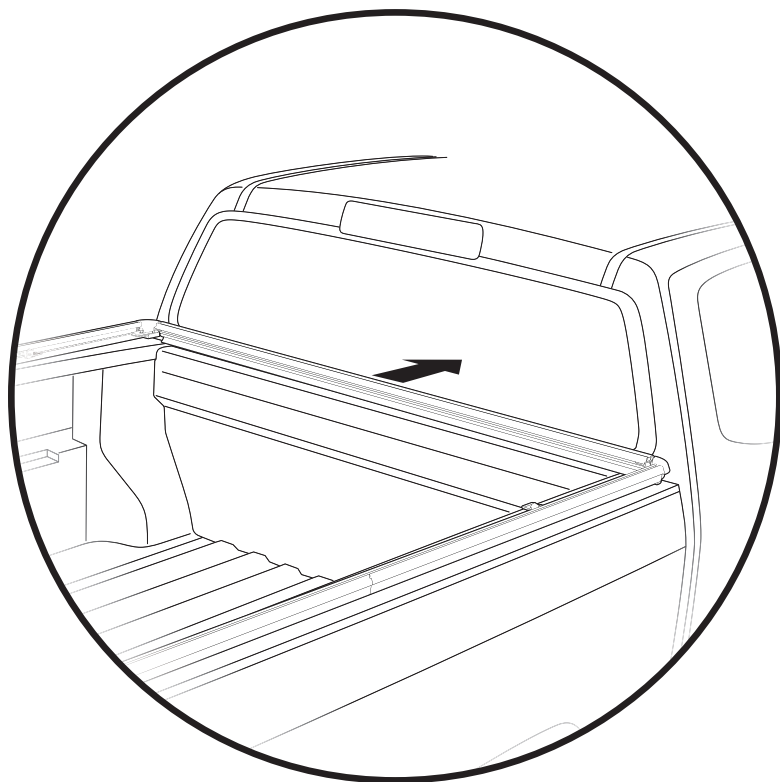

Step 2

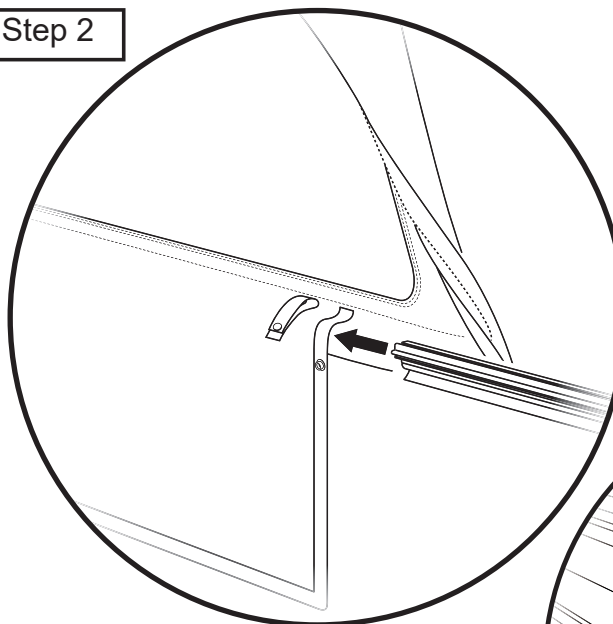

Detail

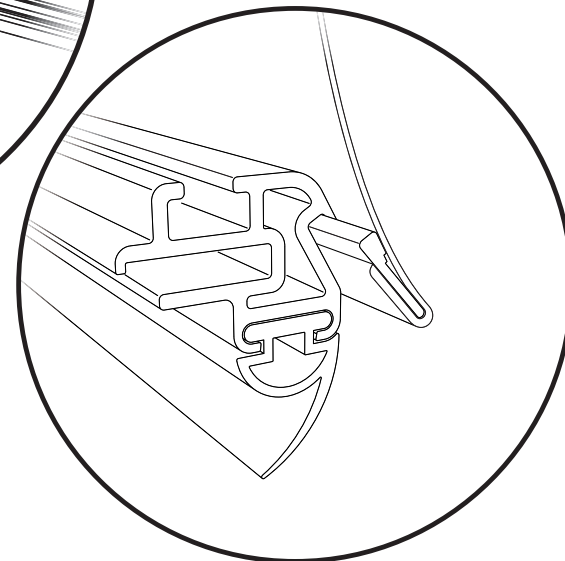

Step 1

Remove the front rail, by sliding it toward the front of the truck bed.

Step 2

Slide the front rail onto the plastic retainer at the bottom of the front window. The rail should go under the large flap.

See Detail.

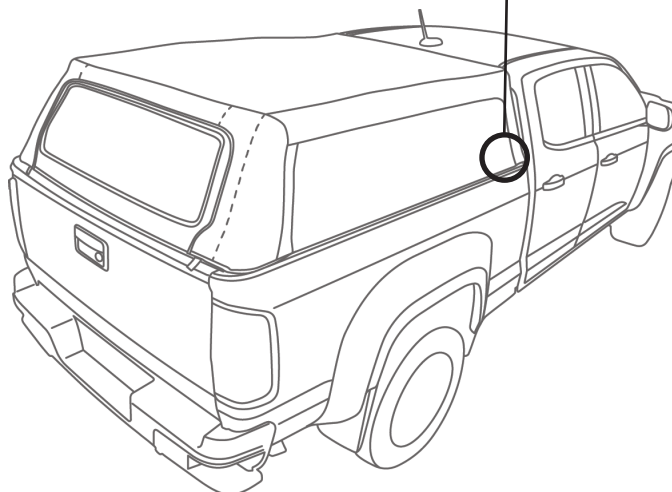

Step 1

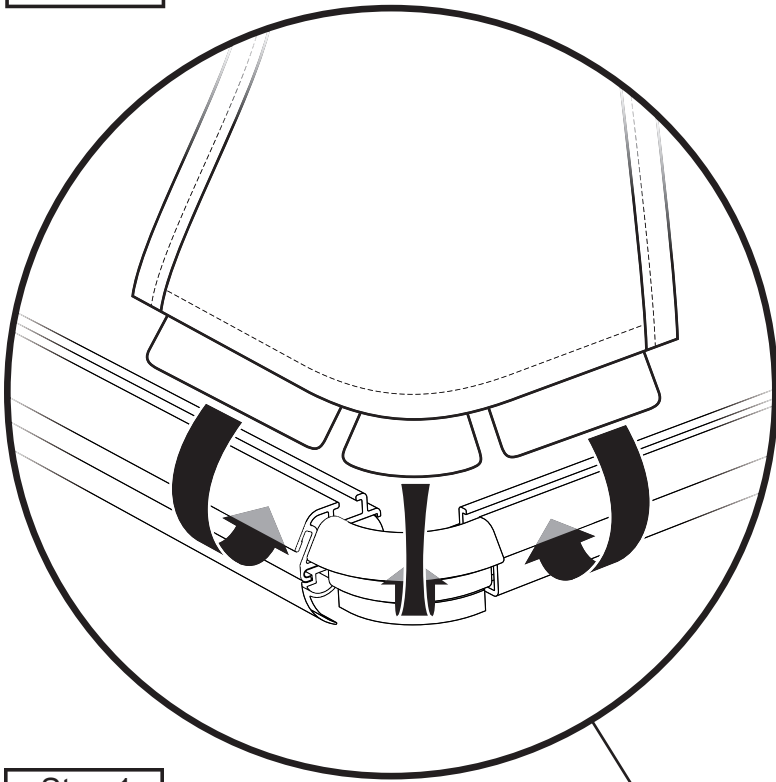

Step 1

Tuck the plastic tabs at the bottom of each corner of the top into the slots in the Side Rails and Front and Rear Rails.

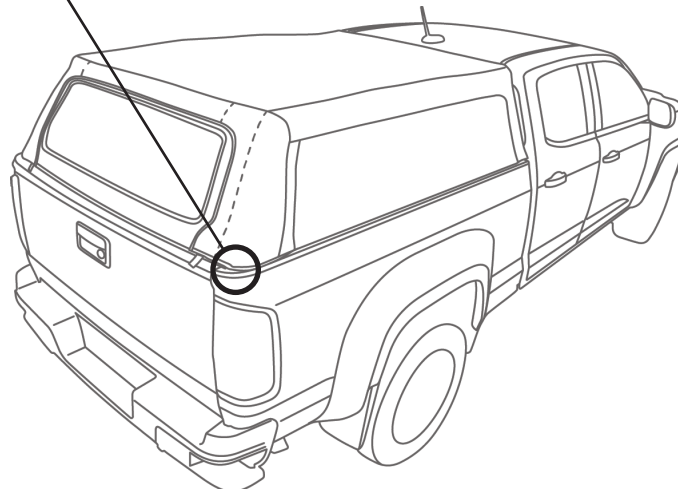



Step 1

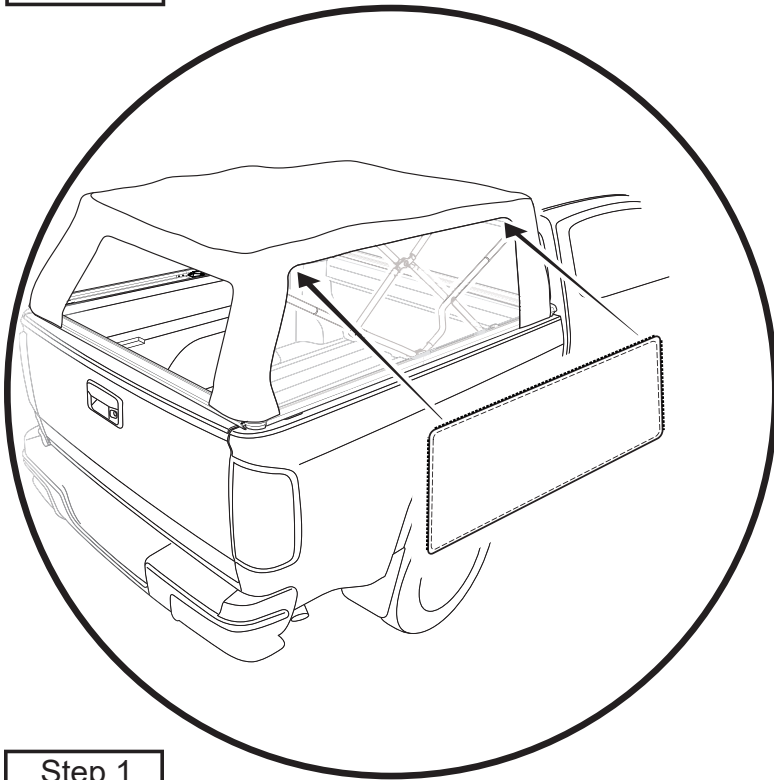

Step 1

For easier access to the zippers, you may want to lift the corners of the top onto the roof fabric.

Zip the Rear Window and Side Curtains into place.

Start with the zipper along the top edge of each panel, and then follow with the side zippers. For ease of installation, start each zipper only about 6".

Once all zippers are started, flip the rear corners into the rail, then zip all zippers completely shut.

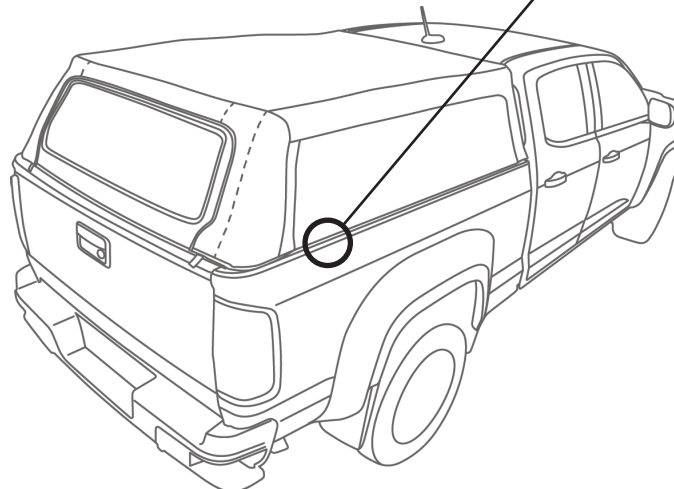

Step 2

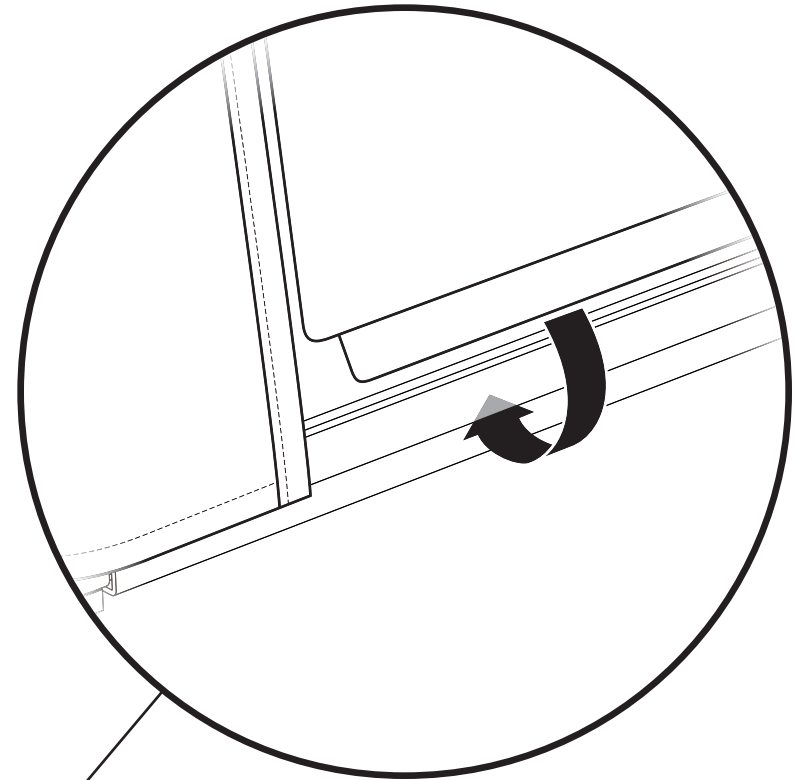

Step 2

Tuck the plastic tab along the bottom edge of each Side Curtain into the slot along the side of each Side Rail.

Tuck the plastic tab along the bottom of the Rear Window into the slot along the side of the Rear Rail.

Step 1

Hardware Kit #576.71

Step 2 CHMSL

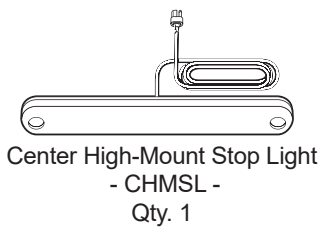
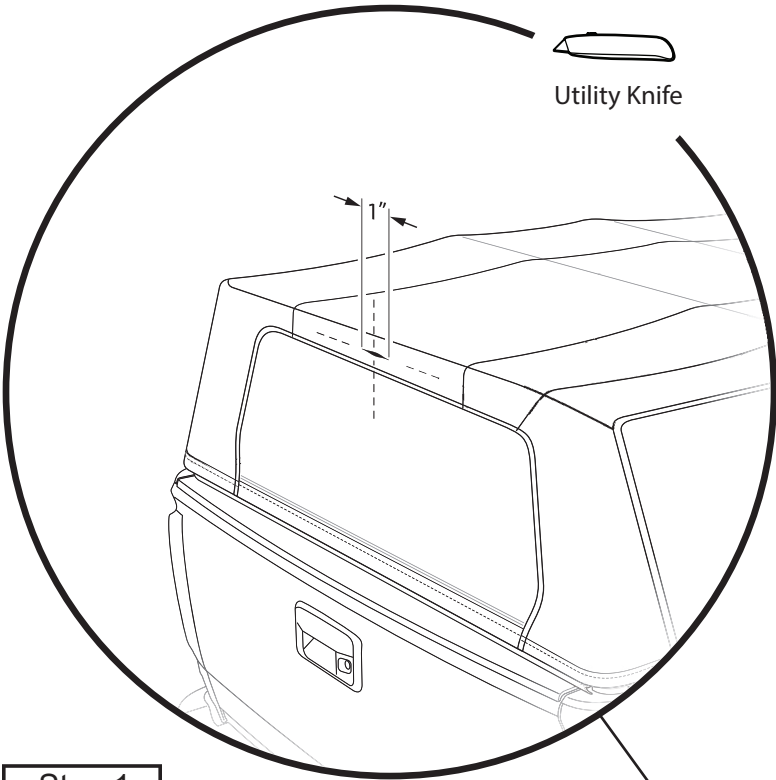

Center High-Mount Stop Light  
- CHMSL -  
Qty. 1

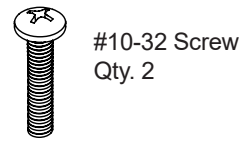

#10-32 Screw  
Qty. 2

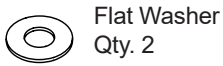

Flat Washer  
Qty. 2

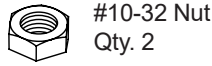

#10-32 Nut  
Qty. 2

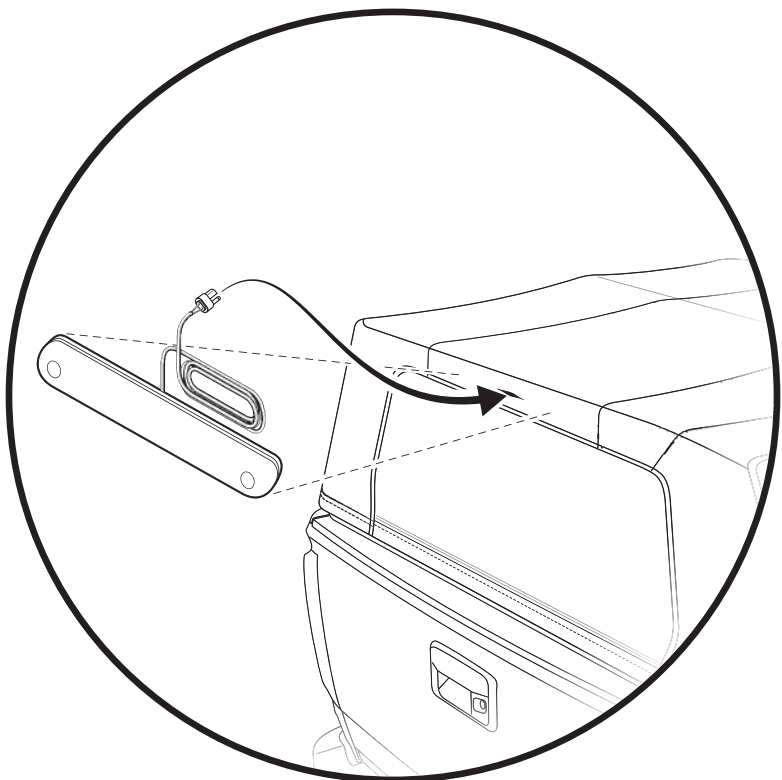

Step 1

Using a utility knife, cut a 1" wide slit through both layers of fabric in the area above the middle of the rear window, and in the vertical center of the fabric.

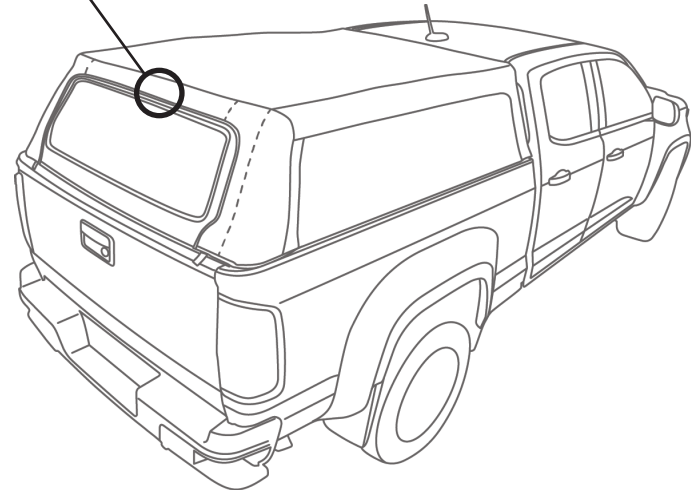

Step 2

Feed the connector end of the CHMSL wire harness through the slit in the top fabric, and pull the wire all the way through.

Make sure that the light is centered, straight and level, and attach the Stop Light to the top fabric using two (2) 10-32 Screws, two (2) Flat Washers and two (2) 10-32 Nuts. The Nuts and Flat Washers go on the inside of the fabric.

You'll need to pierce the fabric for the screws to go through.

Step 1

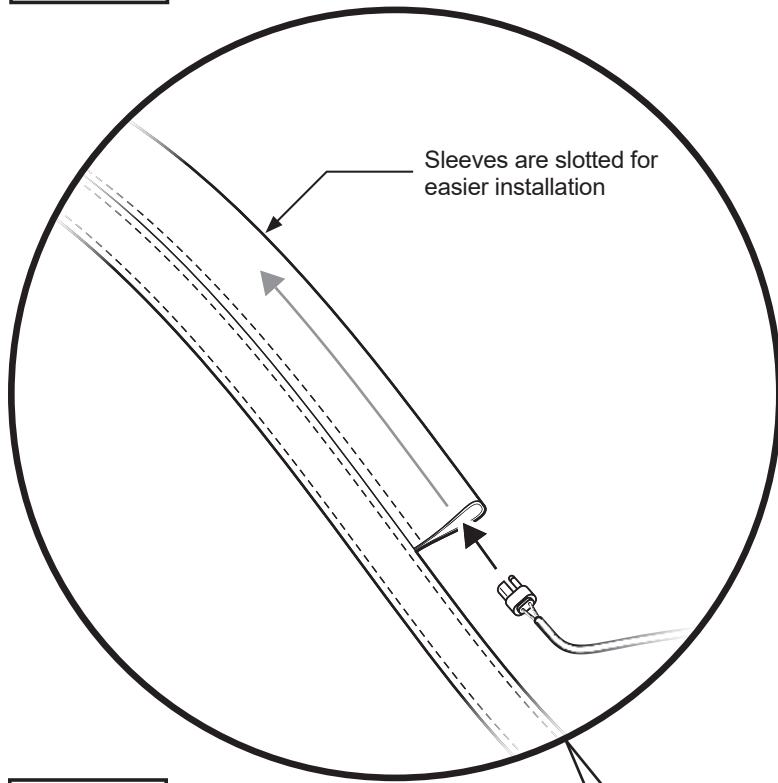

Detail

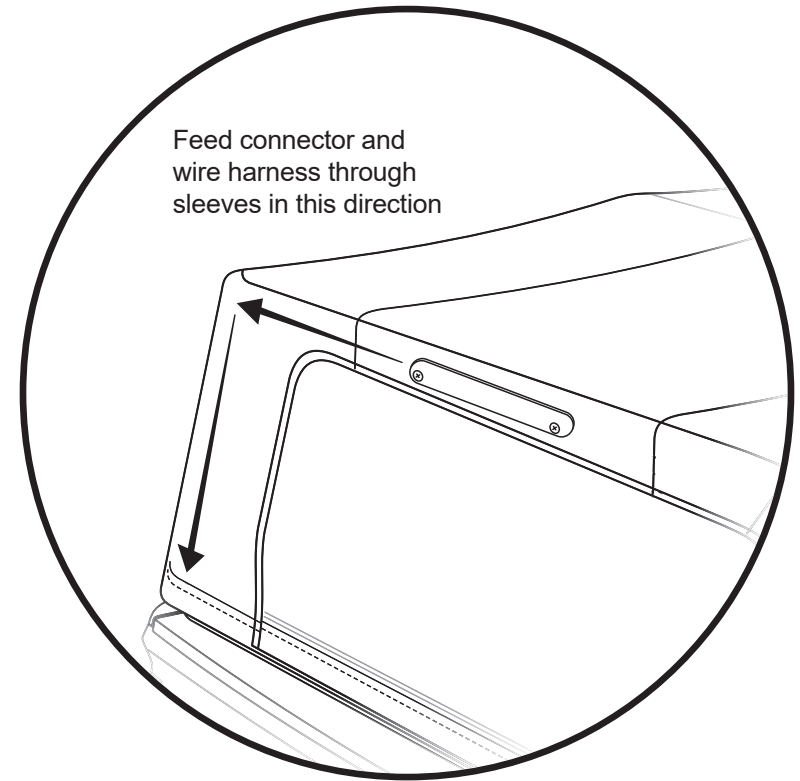

Step 1

Feed the connector and wire harness through the fabric sleeves on the inside of the top.

The sleeves run across the top and down the rear corner of the top fabric.

**NOTE:** Sleeves are slotted to help with installation.

See Detail.

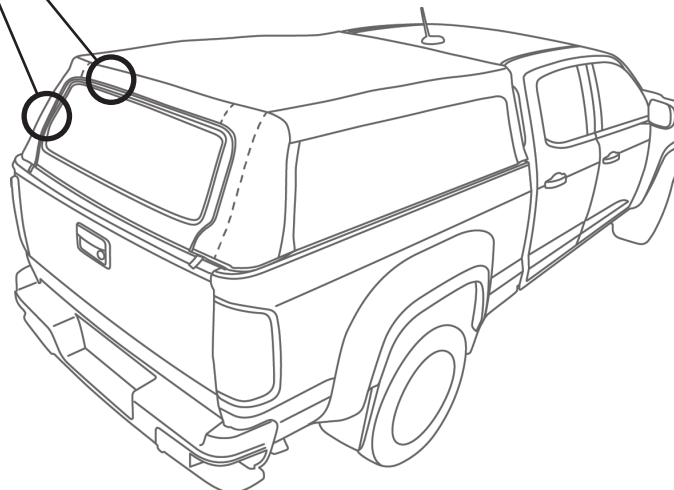

Step 1

Hardware

Step 2 577.58

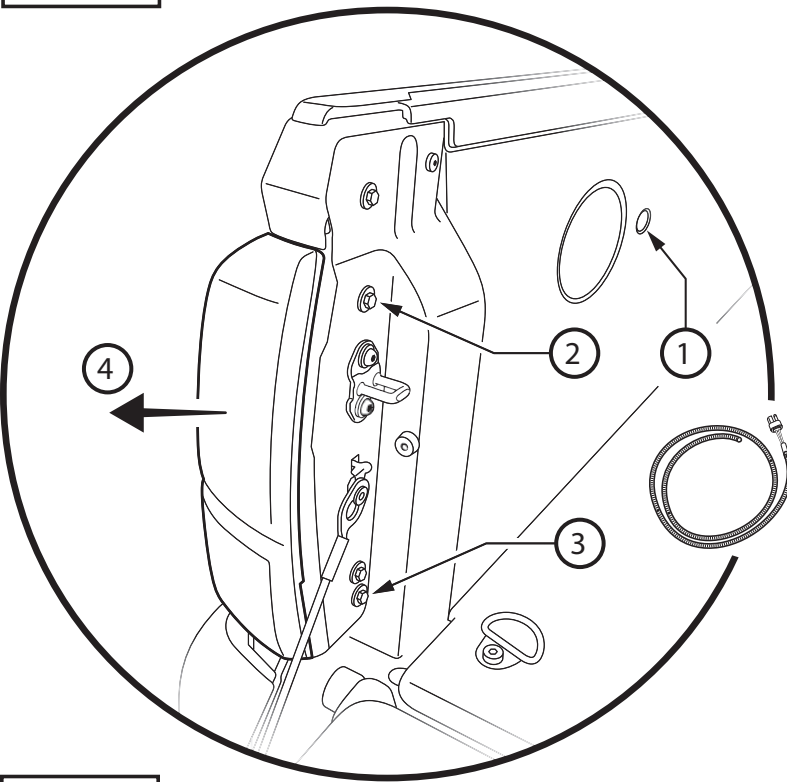

Tools



Step 1

Cut the 29" wire harness 4' (48") from the end with the connector. Feed the cut end through the side of the bed at location ① and through the slot underneath the edge of the cap. Leave about 5" of the wire harness with the connector inside the vehicle bed.

Remove the driver's side tail light assembly.

Remove hex-head screws ② and ③ using a 10mm socket. ④ pull the driver's side tail light assembly away from the vehicle fender, and set it on the tailgate.

Feed wire harness through hole

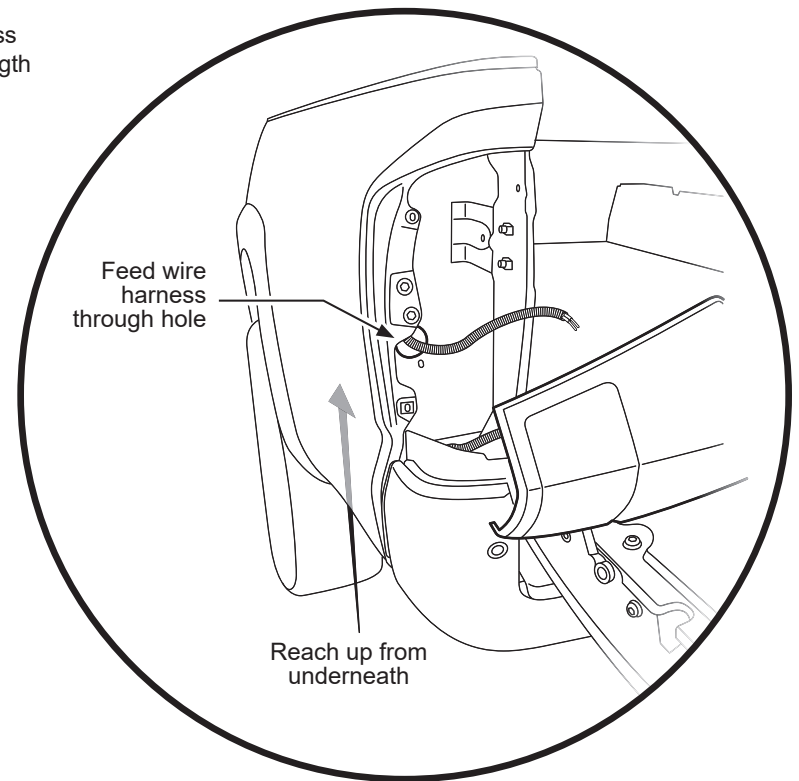

Step 2

Reach up between the outer and inner fender to feed the 4' wire harness through the hole in the tail light receiver portion of the fender.

Pull the wire harness through the hole, and clip the end so it will reach the tail light wires with a bit of slack.

Step 1 577.58

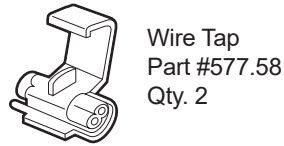
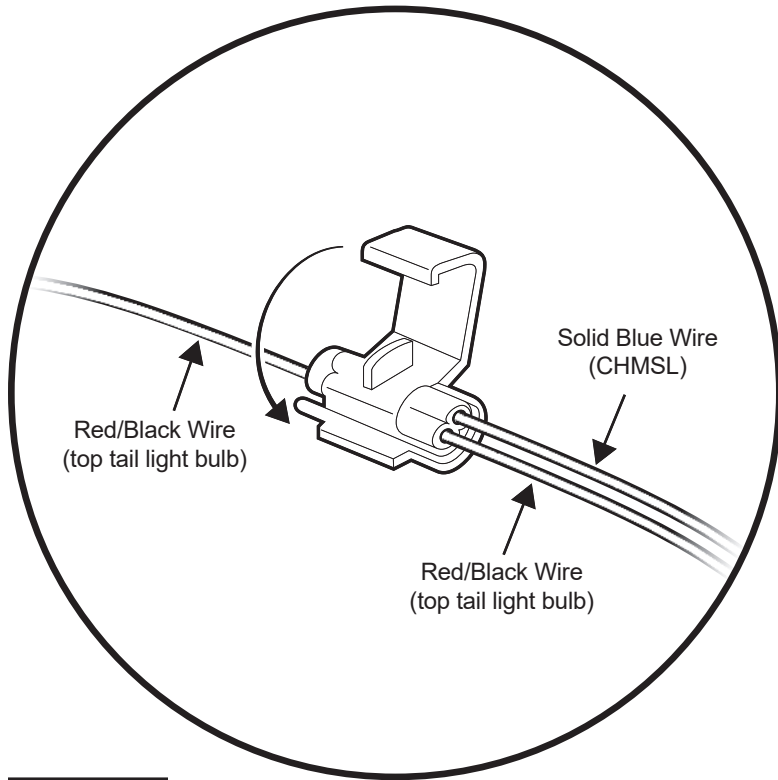

Tools

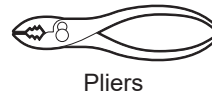

Step 2 577.58

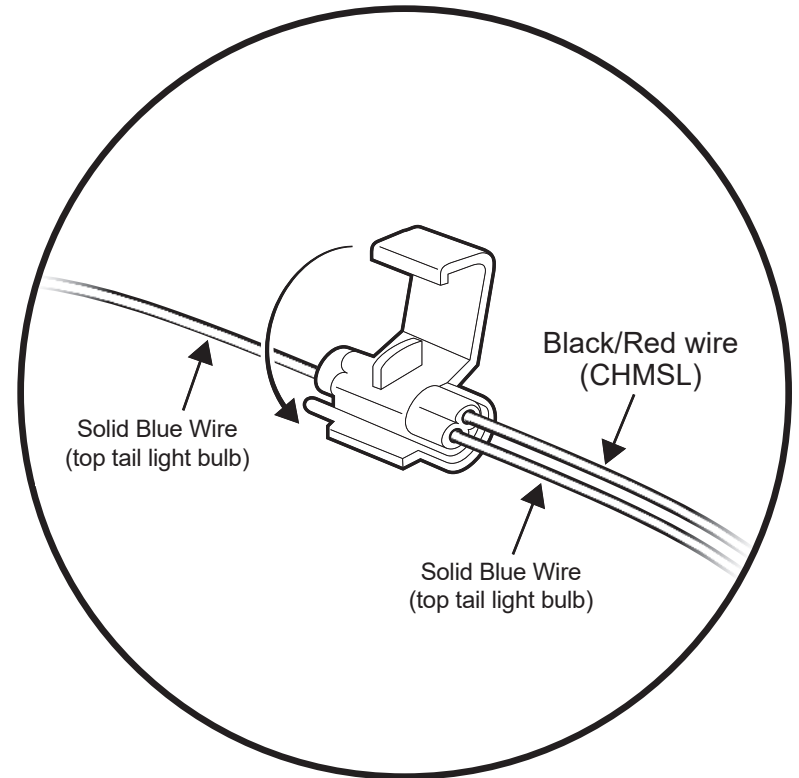

Step 1

On the back side of the driver-side tail light, locate the Red/Black and the solid Blue wires going to the top bulb (brake light bulb).

Splice the Red/Black wire from the tail light top bulb to the solid Blue wire from the CHMSL, using a Wire Tap #577.58 and a pair of pliers.

Step 2

Splice the Solid Blue wire from the tail light top bulb to the Black-Red wire from the CHMSL, using a Wire Tap #577.58 and a pair of pliers.

Step 1

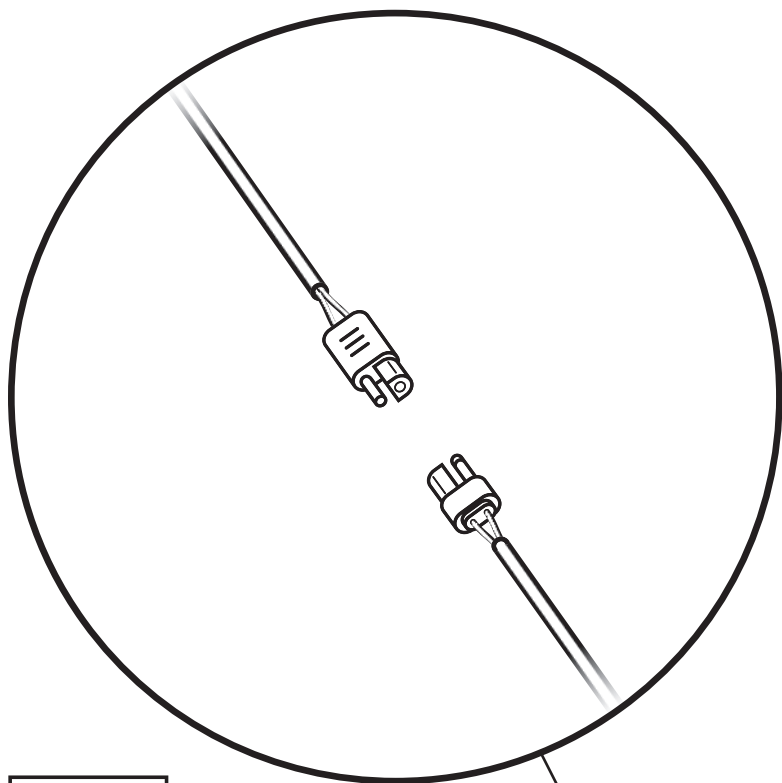

Step 1

After routing the 29' Wire Harness using either Option 1 or Option 2, plug the 2-conductor connectors at the ends of the CHMSL Wire Harness and the 29' Wire Harness together.

**NOTE:** You must unplug these connectors before folding the top down.

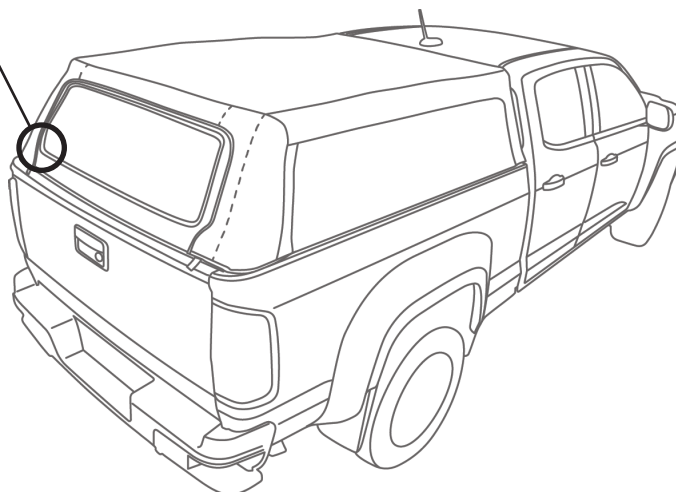

Step 1

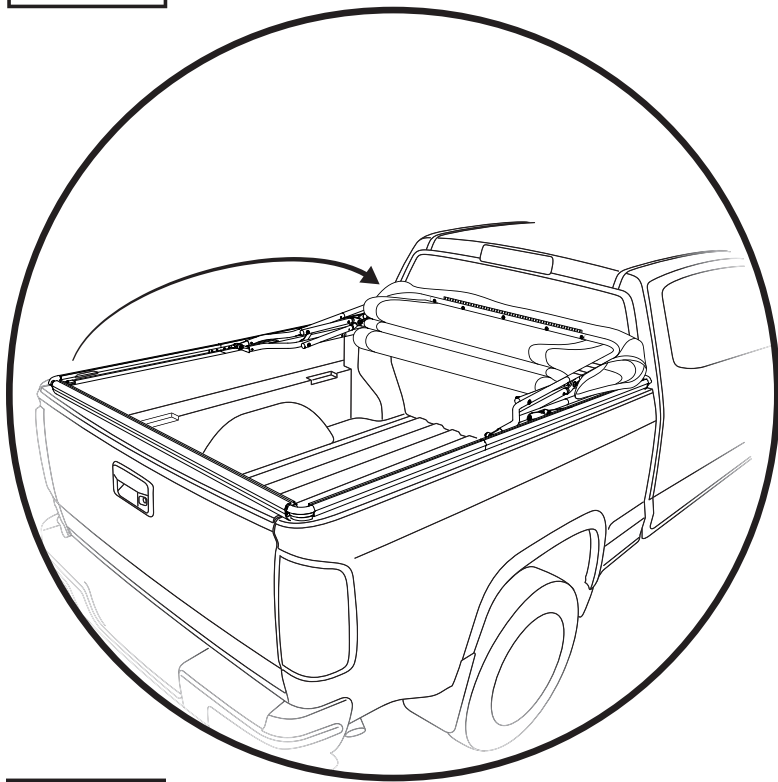

Step 1

To open the top:

- Unzip and remove Side Curtains.
- Unzip and remove Rear Window.
- Release plastic tabs from rails all around.
- Flip rear corners of top fabric up onto roof.
- Fold the top forward so that all the bows collapse and rest on the Front Rail.

Step 2

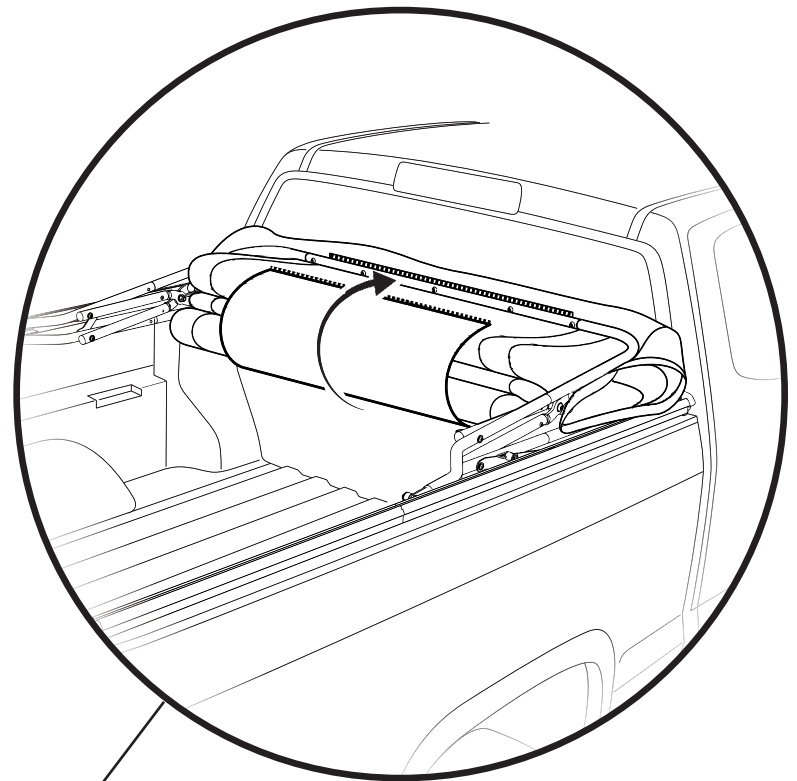

Step 2

Protect the top fabric by wrapping the Boot attached to the Front Window around the Fabric and Bows.

Secure the Boot by zipping it to the zipper for the Rear Window.

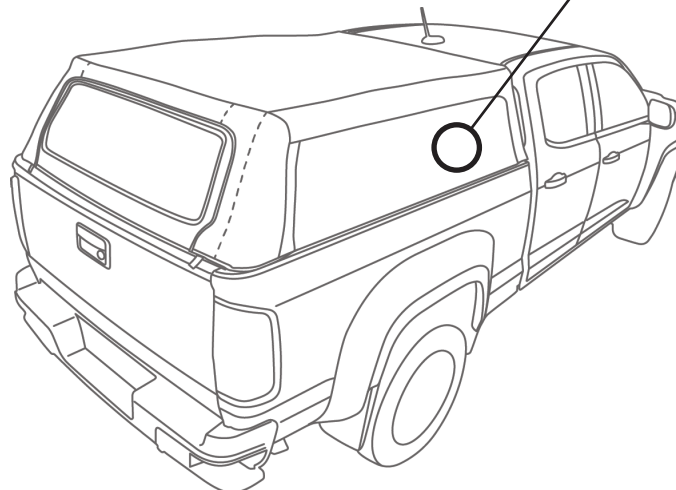

Step 1

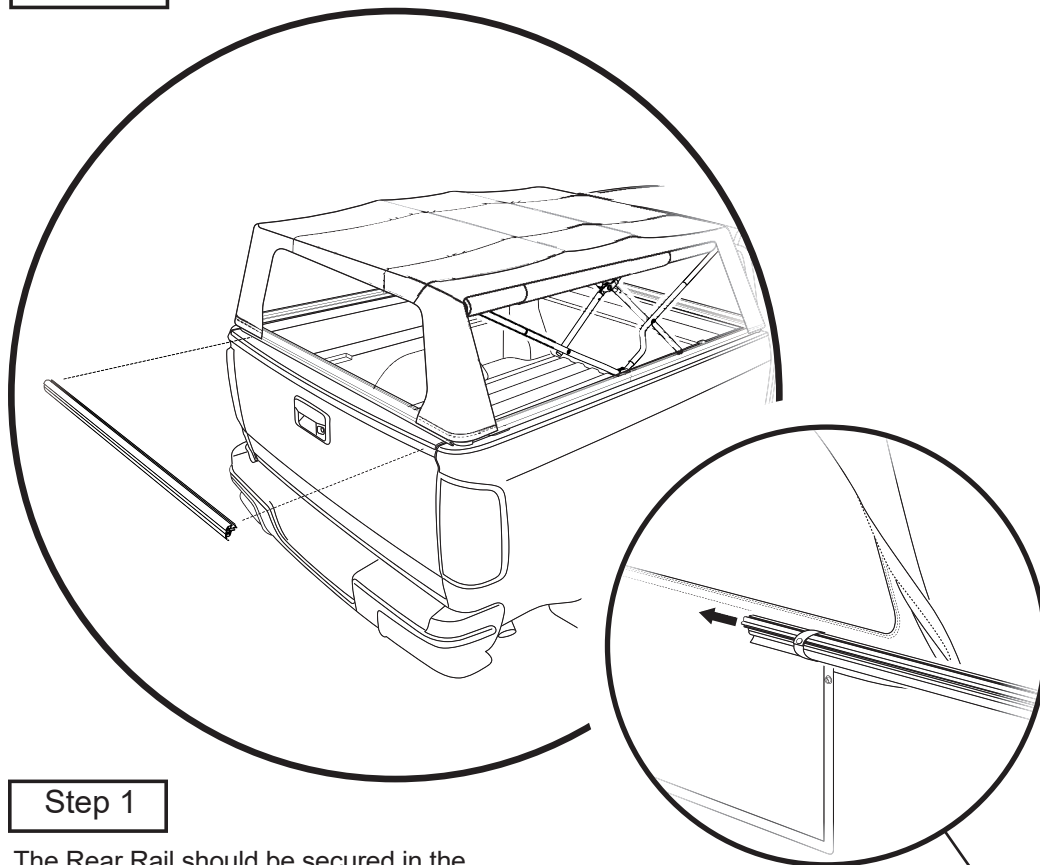

Step 1

The Rear Rail should be secured in the straps at the bottom of the Front Window when the top is folded down.

Wrap the straps around the Rear Rail and snap closed.

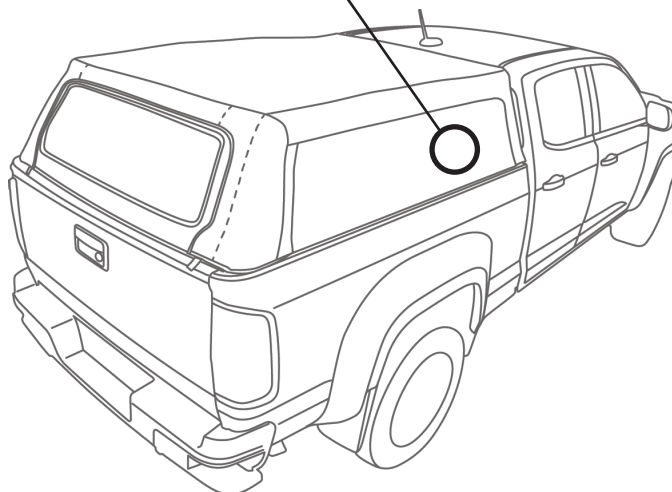



Step 1

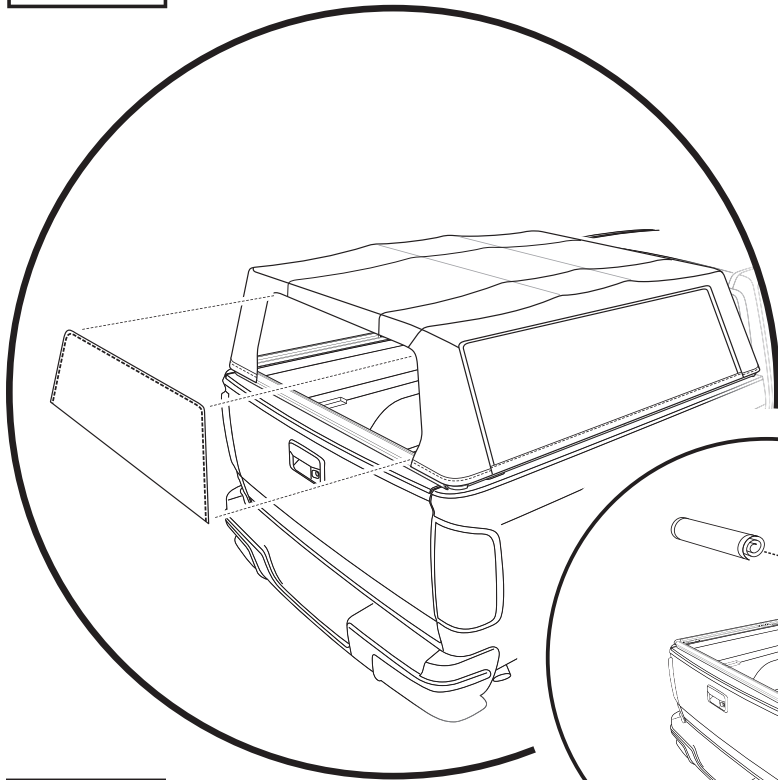

Step 1

With the Fabric Top up, the Rear Window can be stored in the Boot attached to the bottom of the Front Window.

Place the rolled-up Rear Window in the Boot, and zip the Boot closed.

Step 2

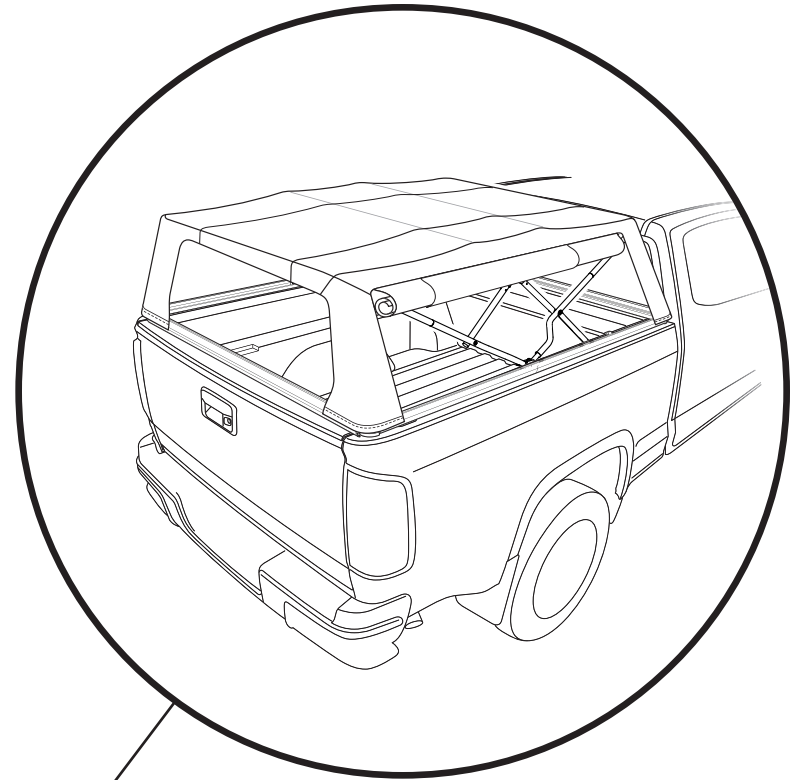

Step 2

With the Fabric Top up, the Side Curtains can be rolled up and secured with attached side flaps.

