









Installation Instructions Bikini®

Vehicle Application

- International Scout II
(including Super Scout)
1972 – 1980
Part Number: 52550

www.Bestop.com - We're here to help! Visit our web site and click on ["Ask a Question"](#). Click here for more [Jeep Accessories by Bestop](#).

INSTALLATION TIME	SKILL LEVEL
 3/4 Hour	 1 - Easy

TOOLS			
 Power Drill 5/32" and 3/32" Bits	 Phillips Screwdriver	 Center Punch	 Safety Glasses



If your vehicle does not have a Bestop Supertop part number 51530, you will need to purchase a Bestop Windshield Header part number 51207 to install this Bikini.

Installation Tips

Before you begin installing this assembly, read all instructions thoroughly.

For a smooth fit:

For ease in installation, the product should be installed at temperatures above 72° F. Below this temperature, the fabric may contract an inch or more, making it difficult to fit to the vehicle. It is normal for fabric to contract and wrinkle when stored in the shipping carton. Within a few days after the installation, the fabric will relax and the wrinkles will disappear.

CAUTION Safety glasses should be worn at all times while installing this product.

WARNING This product is designed primarily to enhance the appearance of the vehicle and to shield the occupants from ordinary weather conditions. Do not rely in any way on the components of this product to contain occupants within the vehicle, or to protect against injury or death in the event of an accident. This product will not protect the occupants from falling objects. Never operate the vehicle in excess of manufacturer's specifications.

WEAR SEAT BELTS AT ALL TIMES

Read and follow, precisely, all installation instructions provided when installing product. Failure to do so may result in a poor fit and could place occupants of the vehicle in a potentially dangerous situation.

Parts List and Hardware Identification

Bikini Top, Qty - 1

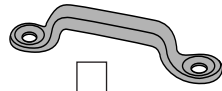

Footman Loop, Part Number 272.29, Qty - 2

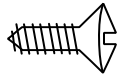

#10 x 1/2" Oval Head Phillips Screw, Part Number 155.49, Qty - 4

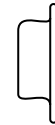

Body Stud, Part Number 9.68, Qty - 2



#6x3/8" Sheet Metal Screw, Part Number 9.69, Qty - 2



Bikini Installation

Step One

Install Footman Loops

Install the Footman Loops on the rear corners of the vehicle. Center the loops on the top, rear corner on each side of the vehicle. Use the loop as a template to mark, center punch and drill two 5/32" holes. Install the Footman Loop with two #10 x 1/2" Oval Head Phillips Screws. Do this on both sides of the vehicle.

Footman Loop

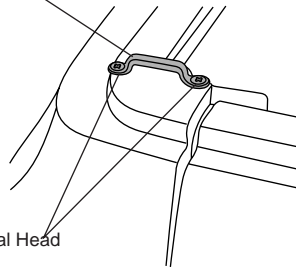

#10 x 1/2" Oval Head Phillips Screw

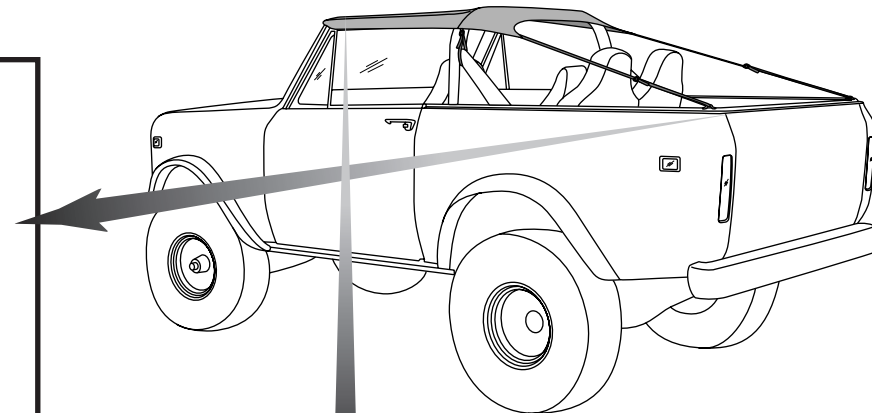

Step Two

Install Bikini Fabric

Slide the extrusion along the front of the Bikini into the channel in the windshield header. Make sure the fabric is centered on the vehicle.

Slide Extrusion into channel

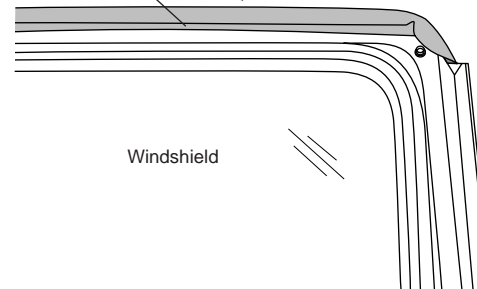

Windshield

Step Three Secure Long Straps

Pull one of the long straps on the rear of the Bikini to the Footman Loop on the rear of the vehicle. Thread the strap through the loop. Pull the end of the strap back and thread it through the buckle sewn to the strap. Repeat this with the other strap.

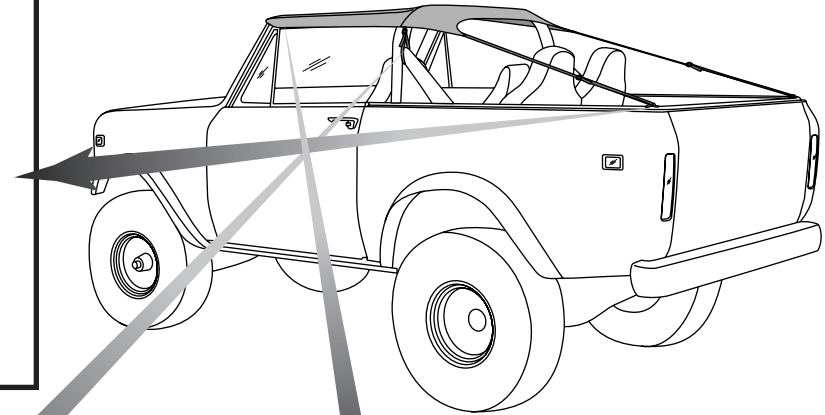
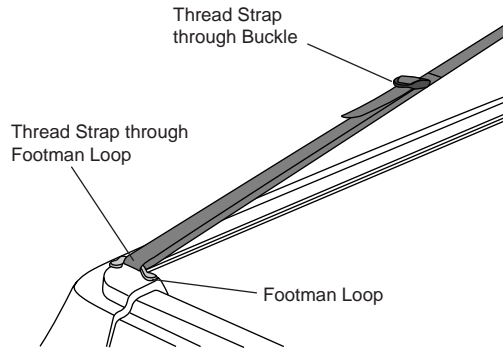

Step Four Secure Short Straps

Make sure the Bikini is centered above the windshield. Wrap the short straps sewn to the top around the sport bars and thread them through the buckles sewn to the top.

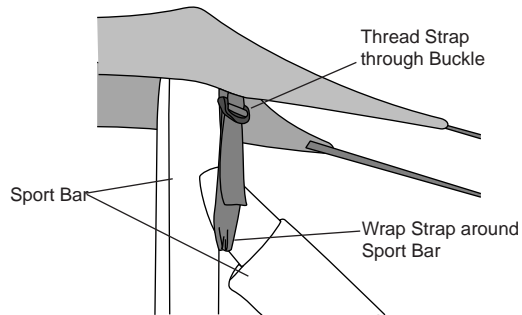

Step Five Secure Windshield Snaps

Secure Windshield Snaps
Snap the Bikini to the studs above the windshield.

If your vehicle does not have these studs mark the location of the snaps on the Bikini. Center punch and drill a 3/32" hole at these locations. Install a Body Stud with a #6 x 3/8" Sheet Metal Screw in each hole.

Tighten all straps.

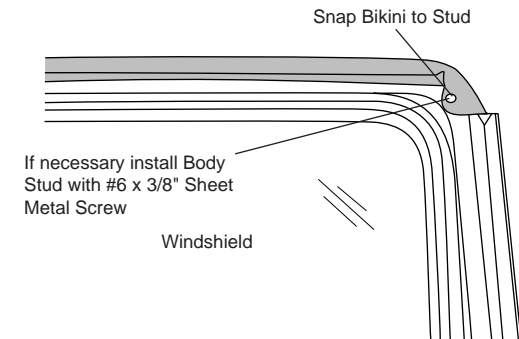

Care and Maintenance of your Bestop Product

Your Bestop product is made of the finest materials available. To keep it looking new and for the maximum possible wear, it will need periodic cleaning and maintenance.

Washing: The fabric should be washed often using soap, warm water and a soft bristle brush. Rinse with clear water to remove all traces of soap or use Bestop-recommended Bestop Cleaner and Bestop Protectant. Bestop Cleaner and Bestop Protectant are specially formulated to provide a total cleaning and protection system. Bestop Cleaner will not harm vehicle finish, is biodegradable and environmentally friendly. Bestop Protectant protects against UV-fading, cracking and hardening.

Water: Seeping through at the seams may be stopped by applying 3-M Scotchgard® on the inside of the seams. Rips in the fabric may be repaired with Bondex® iron on patches. Iron the patches to the Inside of the top, carefully following the Bondex® instructions.

LIMITED WARRANTY

We warrant our product to be free from defects in material and workmanship, for the terms specified below, provided there has been normal use and proper maintenance. This warranty applies to the original purchaser only. All remedies under this warranty are limited to the repair or replacement of any item or items found by the factory to be defective within the time period specified. If you have a warranty claim, first you must call our factory at the number below for instructions. You must retain proof of purchase and submit a copy with any items returned for warranty work. Upon completion of warranty work, if any, we will return the repaired or replaced item or items to you freight prepaid. Damage to our products caused by accidents, fire, vandalism, negligence, misinstallation, misuse, Acts of God, or by defective parts not manufactured by us, is not covered under this warranty.

THE WARRANTY TIME PERIOD IS AS FOLLOWS FOR REPLACE-A-TOP™, SAILCLOTH REPLACE-A-TOP™, SUPERTOP®, SUPERTOP® REPLACEMENT SKINS, SUNRIDER®, AND TIGERTOP®: TWO YEARS FROM DATE OF PURCHASE.

THE WARRANTY TIME PERIOD IS AS FOLLOWS FOR ALL OTHER "SOFT GOODS" MANUFACTURED BY OUR COMPANY (USING PRIMARILY VINYL, PLASTICS, AND/OR FOAM): ONE YEAR FROM DATE OF PURCHASE.

THE WARRANTY TIME PERIOD IS AS FOLLOWS FOR ALL OTHER "HARD GOODS" MANUFACTURED BY OUR COMPANY (USING PRIMARILY METALS, PLASTICS, AND/OR FIBERGLASS): ONE YEAR FROM DATE OF PURCHASE.

ANY IMPLIED WARRANTIES OF MERCHANTABILITY AND/OR FITNESS FOR A PARTICULAR PURPOSE CREATED HEREBY ARE LIMITED IN DURATION TO THE SAME DURATION AND SCOPE AS THE EXPRESS WRITTEN WARRANTY. OUR COMPANY SHALL NOT BE LIABLE FOR ANY INCIDENTAL OR CONSEQUENTIAL DAMAGE.

Some states do not allow limitations on how long an implied warranty lasts, or the exclusion or limitation of incidental or consequential damages, so the above limitations or exclusions may not apply to you. This warranty gives you specific legal rights, and you may also have other rights which vary from state to state.



For further information or request for warranty work, please contact:
Bestop Inc. Customer Service
Toll-Free: (800)845-3567
E-mail: csbestop@Bestop.com
Website: www.Bestop.com