







# Installation Instructions Front Upper Door

(to be used with Element Door)

## Vehicle Application

- Jeep JL Wrangler and Wrangler Unlimited  
(2 Door and 4 Door Models)  
2018 and Newer  
Part Number: 51742

INSTALLATION TIME	SKILL LEVEL
 <b>1/2 Hour</b>	 <b>1 - Easy</b>

TOOLS		
 Safety Glasses	 50/50 Solution Alcohol/Water	 Soft Cloth





### Installation Tips

Before you begin installing this assembly, read all instructions thoroughly.

#### For a smooth fit:

For ease in installation, the product should be installed at temperatures above 72° F. Below this temperature, the fabric may contract an inch or more, making it difficult to fit to the vehicle. It is normal for fabric to contract and wrinkle when stored in the shipping carton. Within a few days after the installation, the fabric will relax and the wrinkles will disappear.

 **CAUTION** Safety glasses should be worn at all times while installing this product.

 **WARNING** This product is designed primarily to enhance the appearance of the vehicle and to shield the occupants from ordinary weather conditions. Do not rely in any way on the components of this product to contain occupants within the vehicle, or to protect against injury or death in the event of an accident. This product will not protect the occupants from falling objects. Never operate the vehicle in excess of manufacturer's specifications.

#### WEAR SEAT BELTS AT ALL TIMES

Read and follow, precisely, all installation instructions provided when installing product. Failure to do so may result in a poor fit and could place occupants of the vehicle in a potentially dangerous situation.

# Front Upper Door – Installation Instructions

## Parts List

Upper Door, Rt. Qty - 1  
Upper Door, Lt. Qty - 1  
74" Adhesive Hook Strip,  
Part Number 12.71 Qty - 1



Allen Wrench, Qty - 1,  
Part Number 276.68



### WARNING

The doors in this product are designed only for protection against the elements. Do not rely on the doors to contain occupants within the vehicle or to protect against injury during an accident. Door handles are only designed to aid in door closure. Door and handle will not support a person's weight.

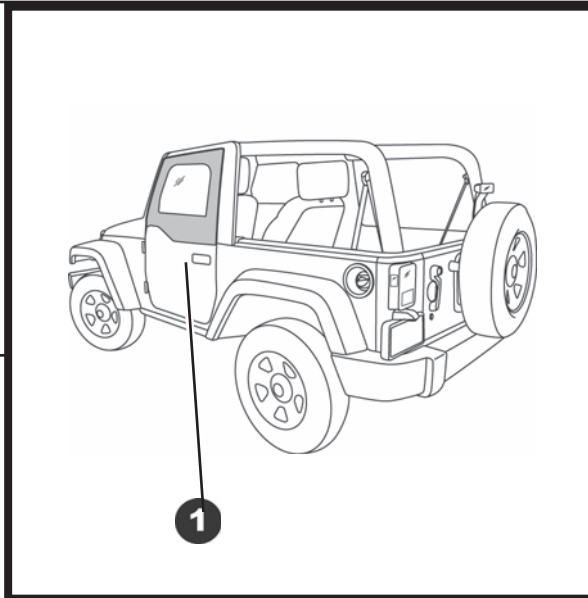

## 1 Install Upper Door

Install the upper door into the lower door. Starting with the front pin, slip the pins into the sockets in the lower door. Make sure that the pins are well seated in the sockets. Close the door to check that it fits properly against the body. If necessary, use a 1/8" Allen Wrench to loosen the Collars on the front and rear upper door pins. The Collars will slide up or down as needed to provide the best fit of the Upper Door against the windshield.

**NOTE** Lubricate the upper door pins with a light weight oil to make it easier to install and remove the upper door.

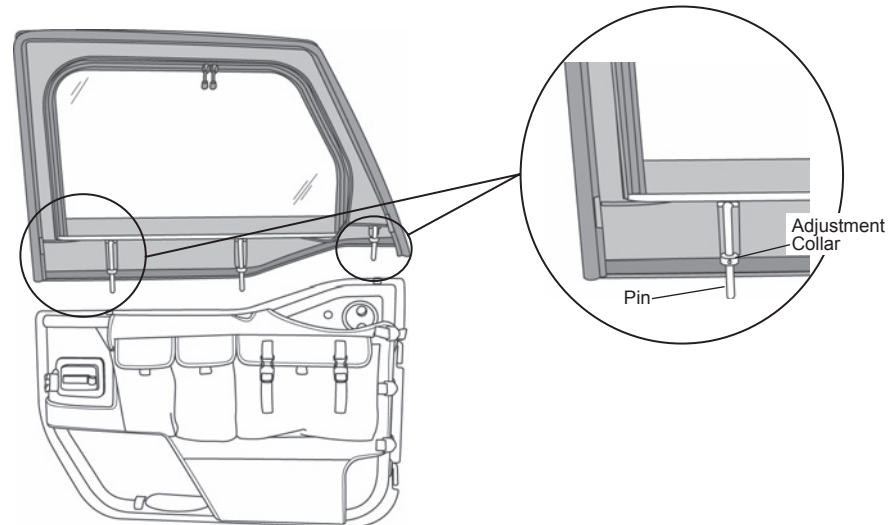

## Front Upper Door – Installation Instructions

### 2 Install Adhesive Hook Strip

Locate the Adhesive Hook Strip in the parts kit. Cut it into two (2) 37" pieces. Install the Adhesive Hook onto the Loop on the inside bottom of the door fabric. Cut the Adhesive Hook as needed to follow the contour of the door bottom.

Press the Upper Door against the Element Door to make sure that the Adhesive Hook Strip will lay flat on the surface of the Element Door. Adjust the Adhesive Hook Strip if necessary.

Clean the area on the Element Door where the Adhesive Hook Strip will be installed using a 50/50 alcohol / water mixture. Carefully peel the paper backing off the Adhesive Hook Strip and press it firmly onto the Element door.

The adhesive requires 72 hours to cure completely. Please leave the Upper Door in position until the adhesive is fully cured.

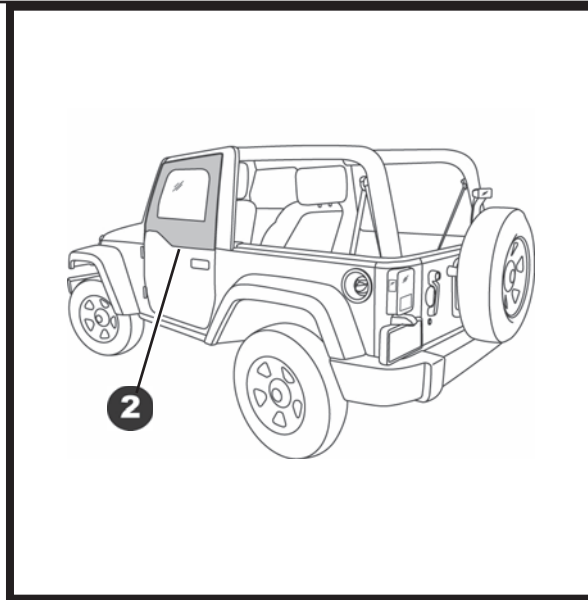

**NOTE** The Adhesive Hook Strip secures the upper door to the lower door and can be applied to the JK Element tubular frame or to the JK Element door with Enclosure kit.

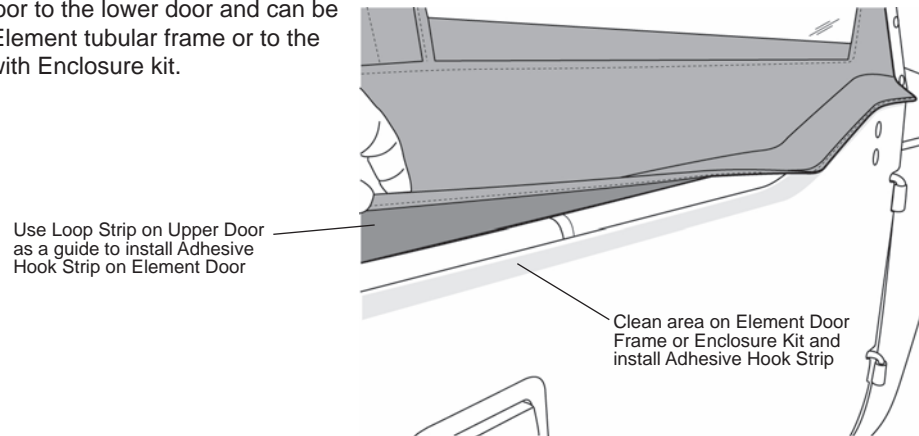

## Front Upper Door – Installation Instructions

---

### Care and Maintenance of your Bestop Product

Your Bestop product is made of the finest materials available. To keep it looking new and for the maximum possible wear, it will need periodic cleaning and maintenance.

**Washing:** The fabric should be washed often using soap, warm water and a soft bristle brush. Rinse with clear water to remove all traces of soap or use Bestop-recommended Bestop Cleaner and Bestop Protectant. Bestop Cleaner and Bestop Protectant are specially formulated to provide a total cleaning and protection system. Bestop Cleaner will not harm vehicle finish, is biodegradable and environmentally friendly. Bestop Protectant protects against UV-fading, cracking and hardening.

**Zippers:** Keeping the zipper cleaned and lubricated with a silicone lubricant will help prevent damage and keep the zippers in a smooth working condition. If a zipper opens behind the slider, the slider may have been spread apart. This problem can usually be repaired by using an ordinary pair of pliers to bring the sides back into parallel. Return slider to the end of the zipper in the normal Open position. Squeeze lightly at first and test the zipper. If the zipper continues to remain open squeeze more firmly with the pliers and try the zipper again. Repeat this procedure until the zipper operates correctly.

**Water:** Seeping through at the seams may be stopped by applying 3-M Scotchgard® on the inside of the seams. Rips in the fabric may be repaired with Bondex® iron on patches. Iron the patches to the Inside of the top, carefully following the Bondex® instructions.

**Snaps:** Keep snaps cleaned and lubricated with silicone to help prevent snaps from sticking to the studs. If a snap does become stuck to a stud, use a screwdriver and GENTLY pry apart to prevent permanent damage to the snap or the top fabric.

