



Installation Instructions

HighRock 4x4™ High Access Front Bumper

Vehicle Application: 1997 - 2006 Jeep® Wrangler and Wrangler Unlimited

•HighRock 4x4™ Front Bumper

Part Number: 42917 / 44917









•HighRock 4x4™ Approach Roller™

Part Number: 42905 (Sold Separately)

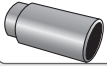
•HighRock 4x4™ Tubular Grill Guard

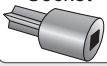
Part Number: 42906 /

44906 (Sold Separately)

INSTALLATION TIME	SKILL LEVEL		
 1-1/2 Hours	 3 - Moderately Difficult		
TOOLS			
 Socket 15mm, 18mm and 1/2"	 Ratchet	 Torx Socket T55	 Wrench 18mm
 Allen Wrench 3/16" and 6mm	 Safety Glasses		



⚠ WARNING Do not use Front Bumper to tow vehicle.

⚠ WARNING This product is designed primarily to enhance the appearance of the vehicle. Do not rely in any way on the components of this product to protect against injury or death in the event of an accident. Never operate the vehicle in excess of manufacturer's specifications.

WEAR SEAT BELTS AT ALL TIMES

Read and follow, precisely, all installation instructions provided when installing product. Failure to do so may result in a poor fit and could place occupants of the vehicle in a potentially dangerous situation.

HighRock 4x4™ High Access Front Bumper Installation Instructions

Parts List and Hardware Identification

42917 HighRock 4x4™ Front Bumper

Front Bumper, Part Number 414.98 (Gloss Finish), Part Number 498.19 (Matte Finish), Qty - 1

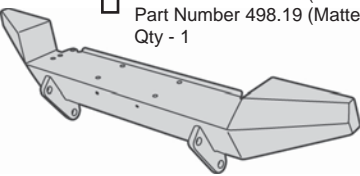

Fare Lead Roller Plate, Part Number 414.19 (Gloss Finish), Part Number 497.50 (Matte Finish), Qty - 1

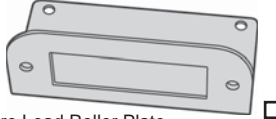

Plastic Hole Plug, Part Number 414.20, Qty - 4



42905 HighRock 4x4™ Approach Roller™ (Sold Separately)

Roller, Part Number 414.21, Qty - 1



Roller Rod, Part Number 414.22, Qty - 1



Flat Washer, Part Number 414.23, Qty - 2



Hex Bolt, Part Number 414.24, Qty - 2



Hardware Kit Part # 498.37

42906 / 44906 HighRock 4x4™ Tubular Grill Guard (Sold Separately)

Tubular Grill Guard, Part Number 414.25 (Gloss Finish), Part Number 497.49 (Matte Finish), Qty - 1

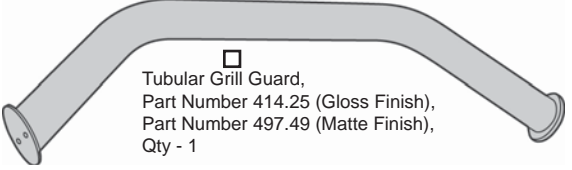

Hex Bolt, Part Number 414.26, Qty - 4



Washer, Part Number 414.27, Qty - 4



Lock Washer, Part Number 414.28, Qty - 4



Hardware Kit Part # 498.36

HighRock 4x4™ High Access Front Bumper Installation Instructions

NOTE If you intend to install a fare lead roller and/or a winch on your bumper, you will need to install them on the bumper before you install the bumper on the vehicle.

If you decide at a later date to install a fare lead roller or winch on your vehicle, it will be easiest to remove the bumper from the vehicle before installing.

If you wish to install a winch without a fare lead roller, skip step 2.

If you do not wish to install a fare lead roller or winch at this time, skip steps 2 and 3.

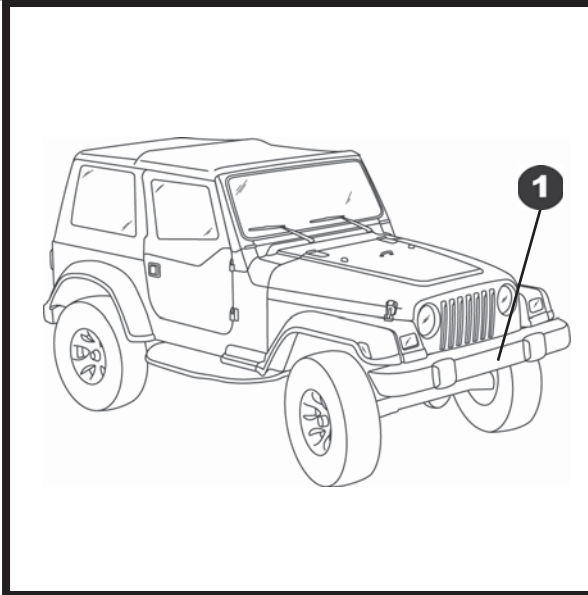

2 Install Fare Lead Roller on Fare Lead Plate

If you have a Fare Lead Roller, use the mounting hardware provided with the roller to install it on the Fare Lead Plate.

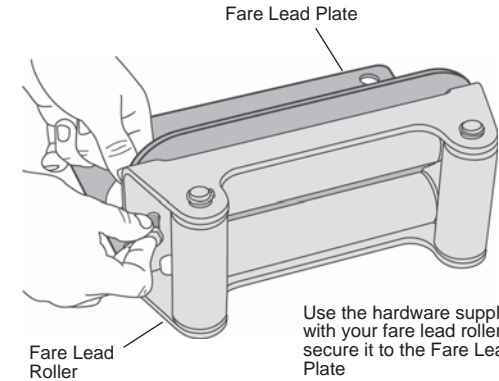

CAUTION

If you have a Jeep® Rubicon with Factory Fog Lights, you must disconnect them before removing the bumper.

1 Remove the Original Bumper

Use a socket wrench with a T55 Torx bit to remove the two (2) torx bolts on the top of the bumper on each side, four (4) bolts altogether. Then use a 15mm socket to remove the sway bar bolt that is closest to the front of the bumper on each side. When these are removed, use an 18mm socket to remove the bolt underneath the bumper on each side. Set these bolts aside to be used to install the HighRock 4x4™ Front Bumper.

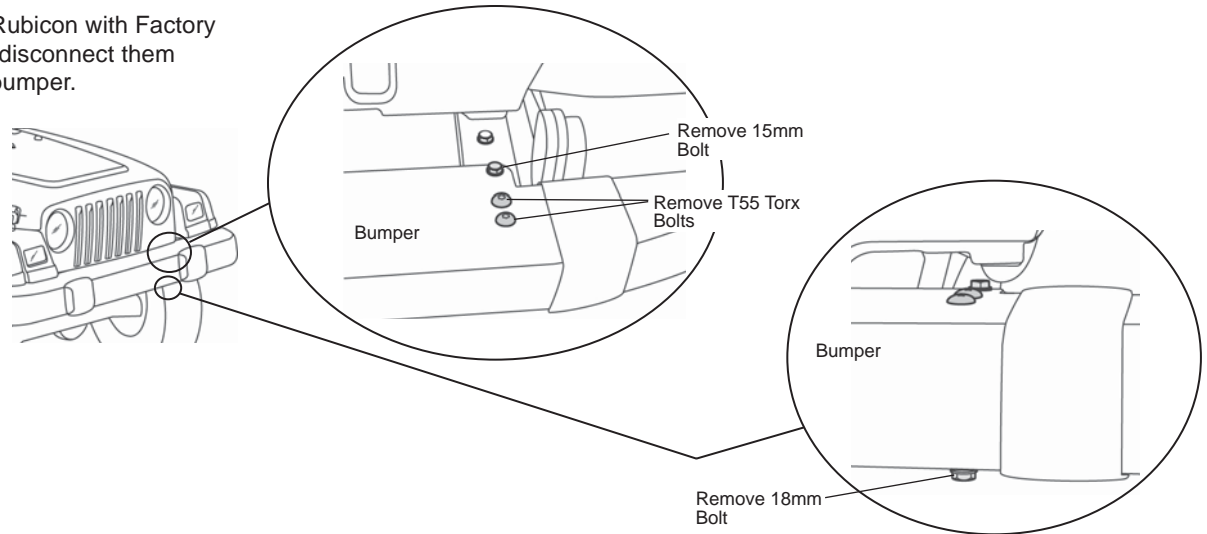

HighRock 4x4™ High Access Front Bumper Installation Instructions

NOTE If you intend to install a winch only, you may install it directly on your bumper and do not need to use the Fare Lead Plate.

3 Install Fare Lead Plate and/or Winch on Bumper

Place the Front Bumper on a flat surface. Place the Fare Lead Plate assembly on the bumper and align the mounting holes. Place the winch on top of the plate and use the hardware provided with the winch to secure it to the bumper.

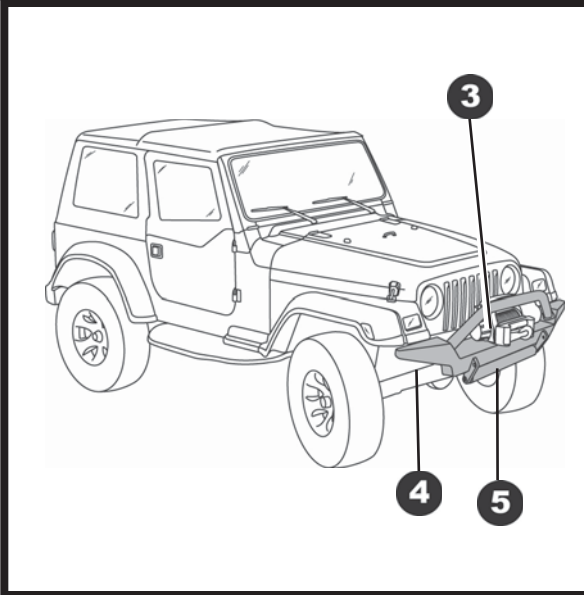
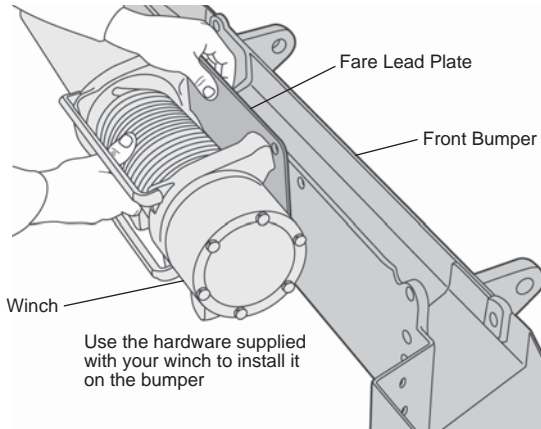

5 Install 42905 HighRock 4x4™ Approach Roller™ – Sold Separately

Place the Roller between the flanges on the Front Bumper and align the holes in the Roller with the holes in the flange. Slide the Rod through the flanges and the Roller. Install a Hex Bolt and a Washer in each end of the Rod to secure it to the flanges.

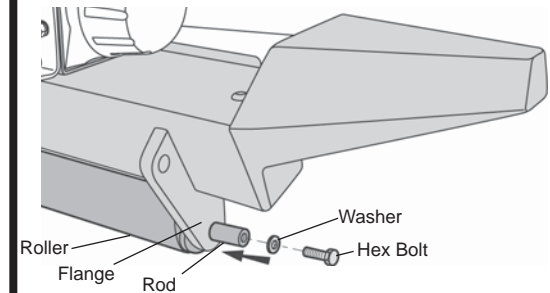

CAUTION Two or more people are required to lift the bumper safely.

4 Install Bumper Assembly

Lift the Front Bumper Assembly onto the front frame rails on the vehicle. Reinstall the hardware that was removed in step 3. If you are not installing an optional Tubular Grill Guard, go to Step 7.

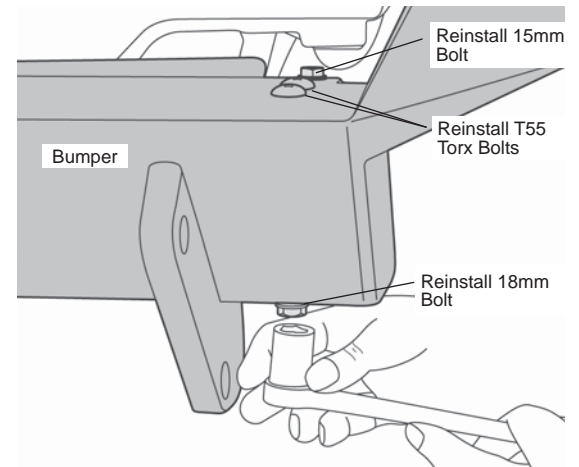

HighRock 4x4™ High Access Front Bumper Installation Instructions

6 Install 42906 HighRock 4x4™ Tubular Grill Guard – Sold Separately

Place the Tubular Grill Guard on the Front Bumper so that the holes in the guard line up with the holes in the angled face of the bumper. Use two (2) Hex Bolts, Washers, Lock Washers and Lock Nuts to secure each side of the Tubular Grill Guard.

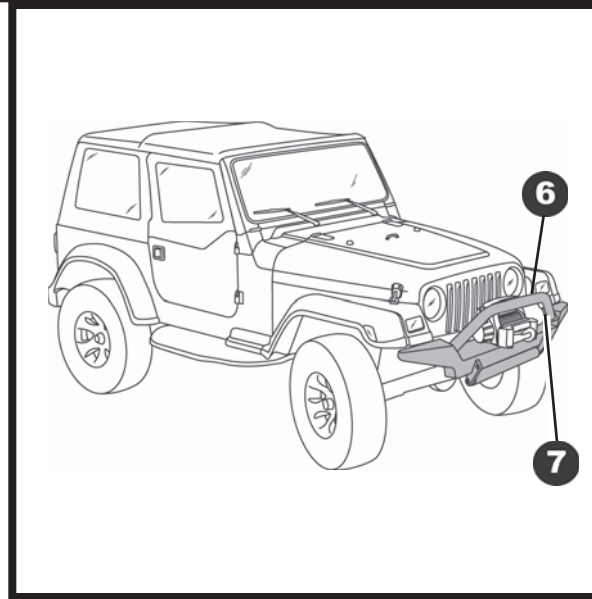
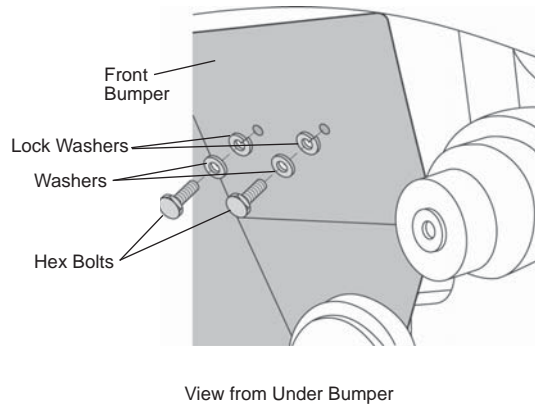
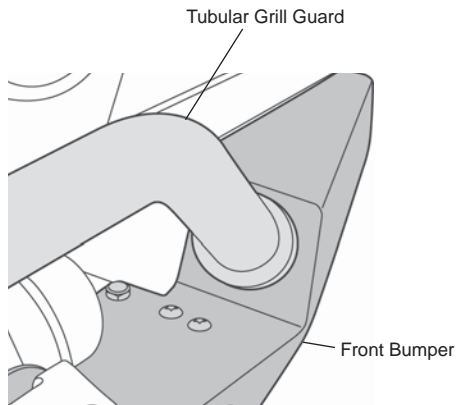

7 Install Hole Plugs

If you are not installing an optional Grill Guard, install the Plastic Hole Plugs from the parts kit in the holes in the bumper.

