



Installation Instructions

HighRock 4x4™ Rear Bumper

Vehicle Application: 1986 - 2006 Jeep® Wrangler and Wrangler Unlimited

•HighRock 4x4™ Rear Bumper

Part Number: 42903 / 44903

•HighRock 4x4™ Departure Roller™

Part Number: 42905 (Sold Separately)

INSTALLATION TIME	SKILL LEVEL
 1-1/2 Hours	 3 - Moderately Difficult
TOOLS	
 18mm, 19mm and 15/16"	 18mm and 19mm
 Safety Glasses	



! WARNING

This product is designed primarily to enhance the appearance of the vehicle. Do not rely in any way on the components of this product to protect against injury or death in the event of an accident. Never operate the vehicle in excess of manufacturer's specifications.

WEAR SEAT BELTS AT ALL TIMES

Read and follow, precisely, all installation instructions provided when installing product. Failure to do so may result in a poor fit and could place occupants of the vehicle in a potentially dangerous situation.

HighRock 4x4™ Rear Bumper Installation Instructions

Parts List and Hardware Identification

- Rear Bumper, Part Number 498.31 (Gloss Finish)
- Part Number 498.32 (Matte Finish)
- Qty - 1

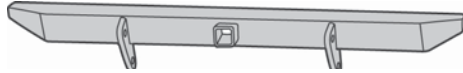



Washers, Part Number 414.47, Qty - 4



Hex Bolts, Part Number 414.45, Qty - 8

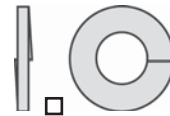

Lock Washers, Part Number 414.46, Qty - 4

Hardware Kit Part # 485.75

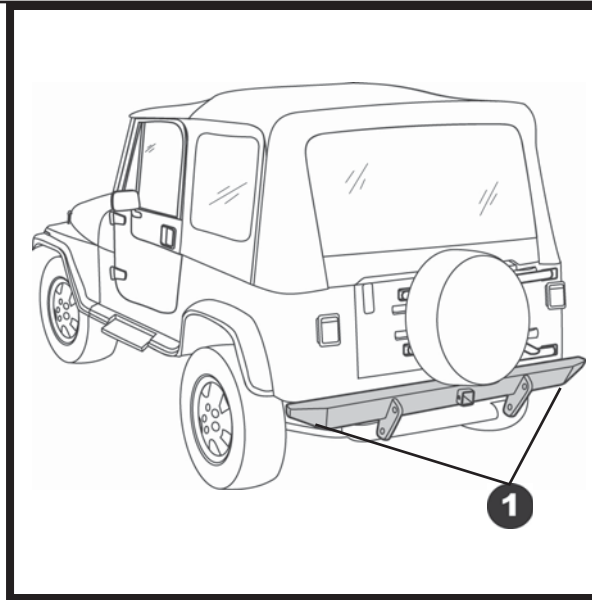

CAUTION

Two or more people may be required to lift the bumper safely.

1 Remove the Original Bumper

Use a socket wrench and an 18mm socket to remove the two (2) bolts on each end of the bumper that attach it to the frame.

Remove the 18mm bolts that attach the bumper to the frame, one under each end of the bumper. Set the bolts aside to be used to install the HighRock 4x4™ Rear Bumper.

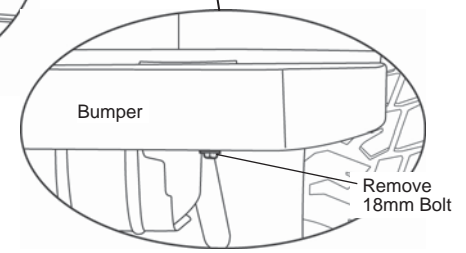
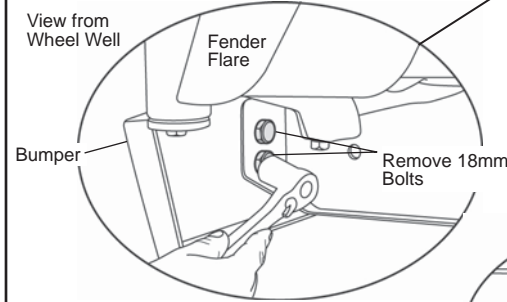
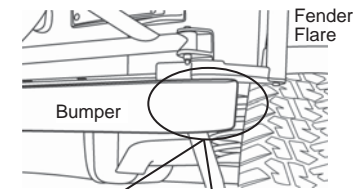

42905 HighRock 4x4™ Departure Roller™ (Sold Separately)



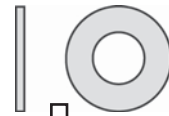

Flat Washer, Part Number 414.23, Qty - 2



Hex Bolt, Part Number 414.24, Qty - 2

Hardware Kit Part # 498.37

HighRock 4x4™ Rear Bumper Installation Instructions



CAUTION

Two or more people may be required to lift the bumper safely.

2 Install Rear Bumper

Place the HighRock 4x4™ Rear Bumper on the vehicle and install two (2) Hex Bolts from the parts kit on each side of the vehicle for '97 - '06 Wranglers. For '86 - '96 Wranglers install four (4) Hex Bolts. Then reinstall the 18mm Bolt under the bumper on each side of the vehicle.

View from Wheel Well

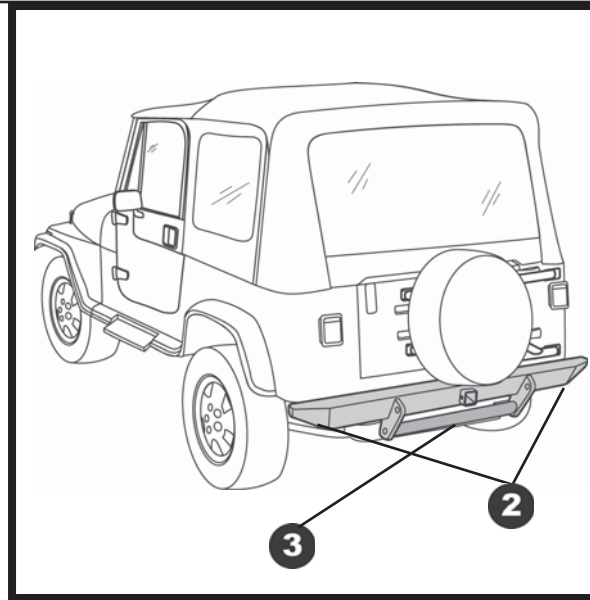
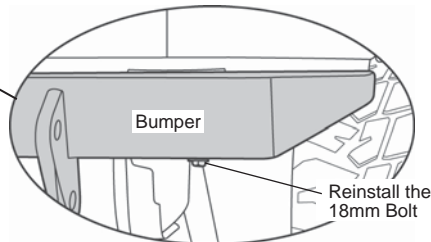
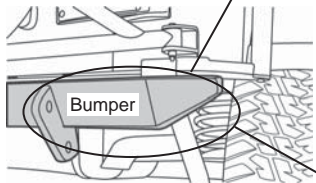
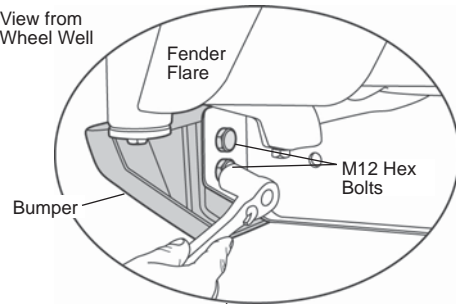

3 Install 42905 HighRock 4x4™ Departure Roller™ – Sold Separately

Place the Roller between the flanges on the Rear Bumper and align the holes in the Roller with the holes in the flange. Slide the Rod through the flanges and the Roller. Install a Hex Bolt and a Washer in each end of the Rod to secure it to the flanges.

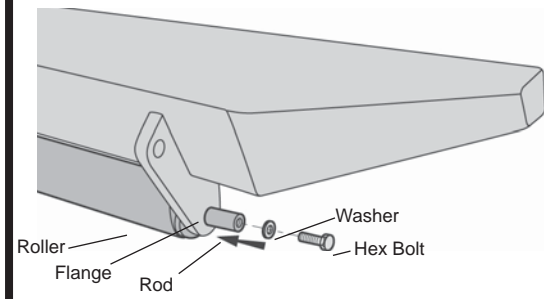

WARNING

Tow Rating Warning

Do not exceed the vehicle manufacturer's recommended towing capacity.



WARNING

DO NOT cut, drill, weld or modify the Bumper.