









# Installation Instructions HighRock 4x4™ Element™ Rear Door Enclosure Kit

## Vehicle Application

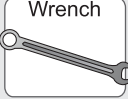
- Jeep JK Wrangler Unlimited  
(4 Door Models)  
2007 – Current  
Part Number: 51804

INSTALLATION TIME	SKILL LEVEL		
 <b>1/2 Hour</b>	 <b>1 - Easy</b>		
TOOLS			
 Safety Glasses	 Phillips Screwdriver	 Wrench 3/8"	 Scissors





## Installation Tips

Before you begin installing this assembly, read all instructions thoroughly.

### For a smooth fit:

For ease in installation, the product should be installed at temperatures above 72° F. Below this temperature, the fabric may contract an inch or more, making it difficult to fit to the vehicle. It is normal for fabric to contract and wrinkle when stored in the shipping carton. Within a few days after the installation, the fabric will relax and the wrinkles will disappear.

 **CAUTION** Safety glasses should be worn at all times while installing this product.









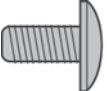

 **WARNING** This product is designed primarily to enhance the appearance of the vehicle and to shield the occupants from ordinary weather conditions. Do not rely in any way on the components of this product to contain occupants within the vehicle, or to protect against injury or death in the event of an accident. This product will not protect the occupants from falling objects. Never operate the vehicle in excess of manufacturer's specifications.

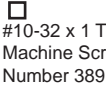
### WEAR SEAT BELTS AT ALL TIMES

Read and follow, precisely, all installation instructions provided when installing product. Failure to do so may result in a poor fit and could place occupants of the vehicle in a potentially dangerous situation.

# HighRock 4x4™ Element™ Rear Door Enclosure Kit – Installation Instructions

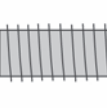
## Parts List

- |   |   |   |
|---|---|---|
| Right Door Enclosure,<br>Part Number 445.96                                       | Qty - 1   |  |
| Left Door Enclosure,<br>Part Number 445.97  | Qty - 1   |   |
| Foam Tape,<br>Part Number 449.09  | Qty - 1   |   |
|  |  |  |
| #10-32 x 1 Truss Head Machine Screw - Black, Part Number 389.71, Qty - 8          |   |   |
|  |  |  |
| #10-32 Low Profile Nut - Black, Part Number 316.94, Qty - 8                       |   |   |
|  |  |   |
| 1/4" Flat Washer, Part Number 257.93, Qty - 2                                     |   |   |
|  |  |  |
| 1/4-20 x 5/8 Truss Head Machine Screw, Part Number 296.14, Qty - 6                |   |   |

## 2 Install Foam Tape on Enclosure Hooks

Cut the Foam Tape to fit the hooks on the Enclosure. Peel the backing off a piece and press it firmly into the curve of the hook. Repeat for all hooks on both Door Enclosures.

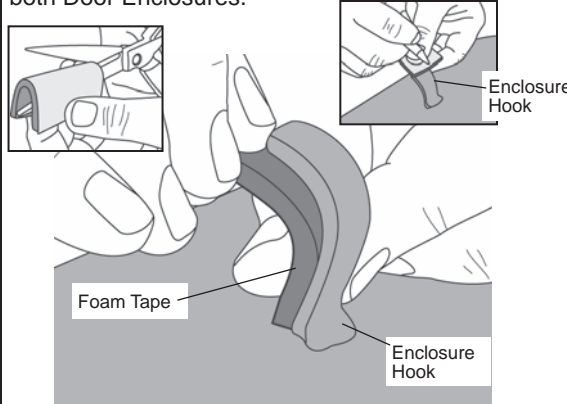

## 3 Install Enclosure Panel

Engage hooks onto Element Door Tube frame and pivot into position. Make sure that the hooks are fully seated onto the tube. Align paddle latch, and mirror holes.

**NOTE** Make sure to install the Element Door Sport Bag with the pockets toward the inside of the vehicle when using both the Enclosure and the Sport Bag.

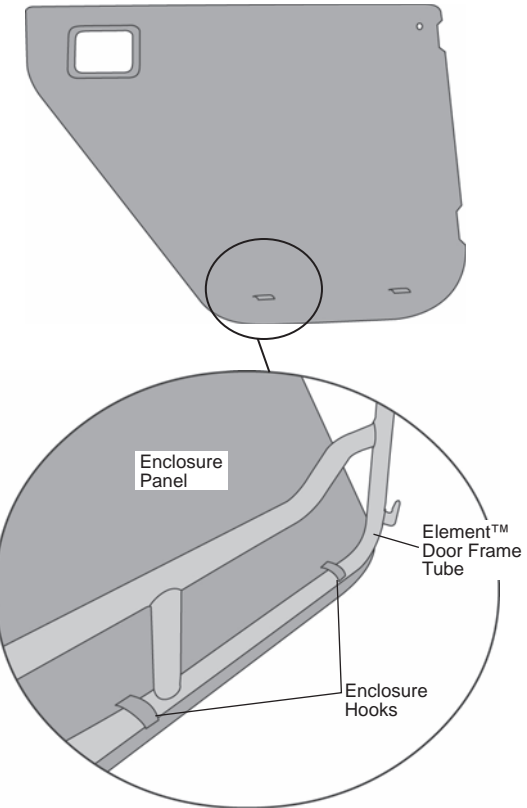

## 1 Remove Paddle Handle and Latch Plate

Remove the four #10-32 x 1 Truss Head Machine Screws and #10-32 Locknuts that secure the Paddle Handle and Latch Plate to the door. Remove the three screws that mount the mirror to the door.

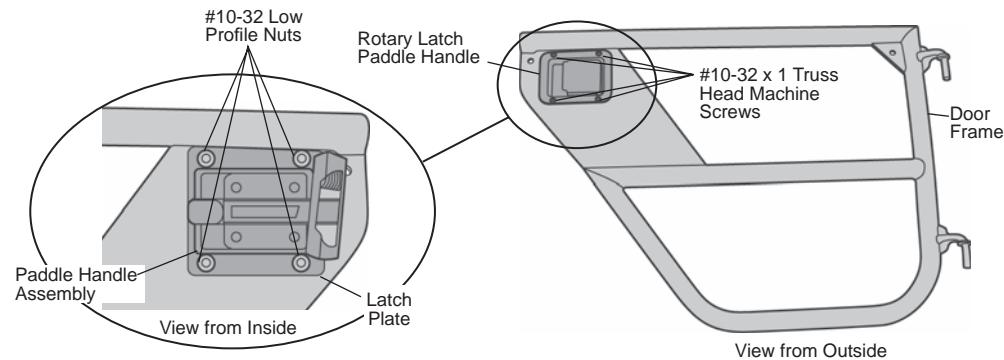

## HighRock 4x4™ Element™ Rear Door Enclosure Kit – Installation Instructions



### WARNING

It is important that the Paddle Handle must align correctly with the automobile manufacturer's original equipment steel latch pin located on the vehicle. Failure to properly install the paddle handle may result in the door accidentally opening. IMPROPER CLOSURE COULD RESULT IN SERIOUS INJURY OR DEATH TO THE OCCUPANTS. WEAR SEAT BELTS AT ALL TIMES. DRIVE CAREFULLY.



### WARNING

The Element Door System is equipped for protection against the elements. The door will not contain occupants during an accident. Wear Seatbelts at all times

**IMPORTANT:** You should check alignment of the Paddle Handle to the steel latch pin before tightening the screws. If out of alignment, align and retighten the screws securely. Repeat for both lower doors.

## 4

### Reinstall Paddle Handle

Insert the Paddle Handle into the opening in the door plate so that the latch mechanism is inside of the vehicle and the Rotary Latch Mechanism is toward the rear of the door. Place the Latch Plate over the Paddle Handle on the inside of the door. Align the holes in the Paddle Handle and Latch Plate. Insert four #10-32 x 1 Truss Head Machine Screws from the outside and secure them with #10-32 Locknuts. Do not tighten the screws until all four are in place.

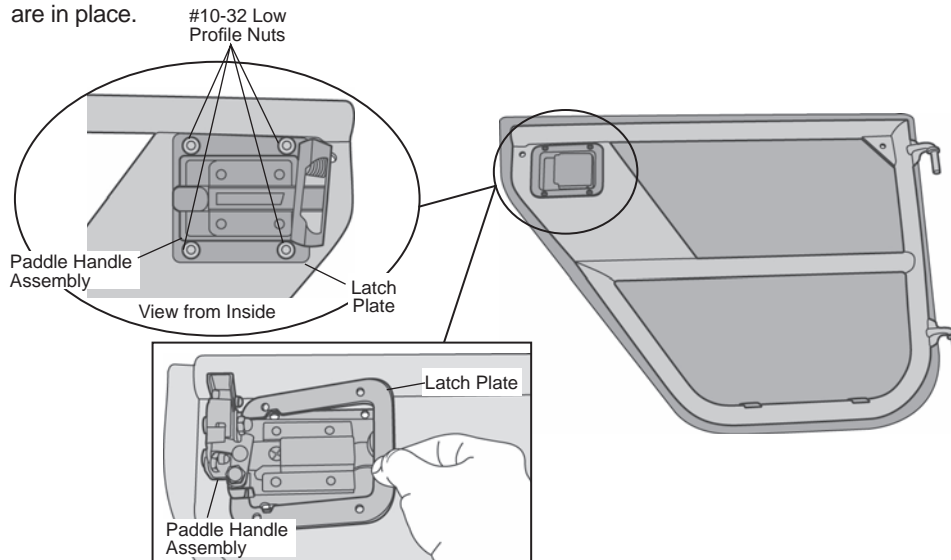

## 5

### Secure Mirror Holes

Install an 1/4-20 Truss Head Screw and 1/4" Washer in each door to secure the Enclosure.

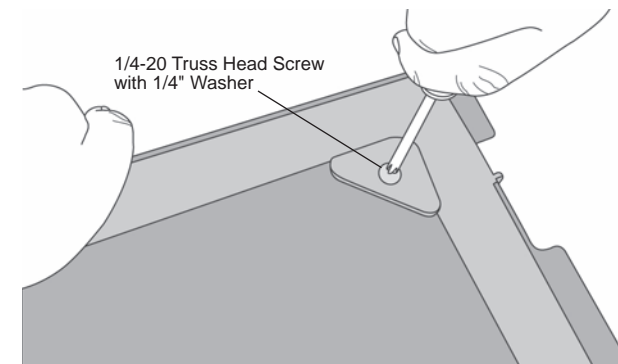

## 6

### Install Enclosure Seal

Once Enclosure panel is in place, install the Enclosure Seal. Peel off the adhesive tape on one end of the seal and press it onto the inside top back corner of the Enclosure panel. Work towards the front of the door aligning the seal to the outer most edge of the Enclosure panel and peeling off the backing tape as you go. Trim the excess seal on the ends and cut the seal where it is over the door pins.

