



# Installation Instructions Supertop for Truck

US Patent 6827391

## Vehicle Application:

•Chevrolet S-10 6' bed  
1994 - 2004  
Part Number: 76302



•Chevrolet Colorado 6' bed  
2004 - 2011  
Part Number: 76302

•GMC Sonoma 6' bed  
1994 - 2004  
Part Number: 76302

•GMC Canyon 6' bed  
2004 - 2011  
Part Number: 76302

•Ford Ranger 6' bed  
1982 - 2011  
Part Number: 76302









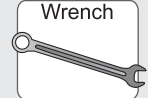

•Mazda B-Series 6' bed  
1994 - 2006  
Part Number: 76302

INSTALLATION TIME	SKILL LEVEL
 <p>1-1/2 Hours</p>	 <p>2 - Moderately Easy</p>

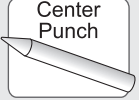

**! WARNING** We recommend that the Third Brake Light supplied with this assembly be professionally wired.

**! CAUTION** Safety glasses should be worn at all times while installing this product.

TOOLS			
 <p>Tape Measure</p>	 <p>Phillips Screwdriver</p>	 <p>Wrench 7/16" and 9/16"</p>	 <p>Power Drill 1/8" Bit</p>
 <p>Center Punch</p>	 <p>Scissors</p>	 <p>50/50 Solution Alcohol/Water</p>	 <p>Soft Cloth</p>
 <p>Safety Glasses</p>	 <p>Utility Knife</p>		

**! WARNING** DO NOT use the Pickup Top Frame as a mounting system for the support or transport of any items. It has been designed only as a support system for the fabric deck and windows.

## Installation Tips

**Before you begin installing this assembly, read all instructions thoroughly.**

### For a smooth fit:

For ease in installation, the product should be installed at temperatures above 72° F. Below this temperature, the fabric may contract an inch or more, making it difficult to fit to the vehicle. It is normal for fabric to contract and wrinkle when stored in the shipping carton. Within a few days after installation, the fabric will relax and the wrinkles will disappear.

DO NOT INSTALL THIS PRODUCT ON ANY VEHICLE OTHER THAN THOSE LISTED ABOVE. This product is only designed for the vehicles listed above. Failure to install this product on the proper vehicle could cause injury to the vehicle occupants and damage to the product.

**! WARNING** This product is designed primarily to enhance the appearance of the vehicle and to shield the occupants from ordinary weather conditions. Do not rely in any way on the components of this product to contain occupants within the vehicle, or to protect against injury or death in the event of an accident. This product will not protect the occupants from falling objects. Never operate the vehicle in excess of manufacturer's specifications.

### WEAR SEAT BELTS AT ALL TIMES

Read and follow, precisely, all installation instructions provided when installing product. Failure to do so may result in a poor fit and could place occupants of the vehicle in a potentially dangerous situation.

# Supertop for Truck Installation Instructions

Supertop Fabric	Qty - 1
Side Panel, Right	Qty - 1
Side Panel, Left	Qty - 1
Rear Window	Qty - 1
32" Buckle Straps	Qty - 2
Elastic Garter	Qty - 2
Self-Adhesive Hook Strip, 53-3/4"	Qty - 1
Foam Tape, 13'	Qty - 1

## Parts List and Hardware Identification

Tailgate Bracket, Left, Part Number 412.09, Qty - 1

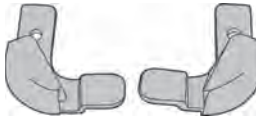

Tailgate Bracket, Right, Part Number 412.08, Qty - 1



Third Brake Light, Part Number 397.52, Qty - 1



Bow Tie Down Assembly, Part Number 194.04, Qty - 2

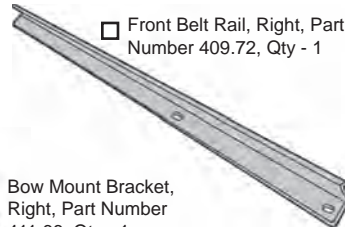

Front Belt Rail, Right, Part Number 409.72, Qty - 1

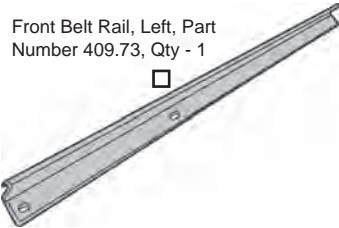

Front Belt Rail, Left, Part Number 409.73, Qty - 1

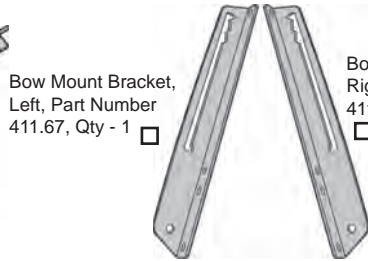

Bow Mount Bracket, Left, Part Number 411.67, Qty - 1

Bow Mount Bracket, Right, Part Number 411.66, Qty - 1



Clamp, Part Number 411.75, Qty - 4

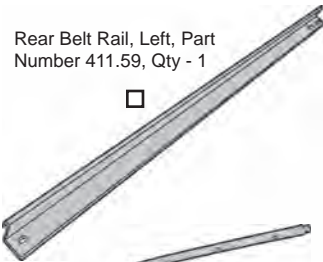

Rear Belt Rail, Left, Part Number 411.59, Qty - 1



Front Bow, Right, Part Number 411.76, Qty - 1

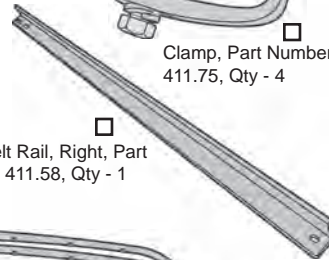

Rear Belt Rail, Right, Part Number 411.58, Qty - 1

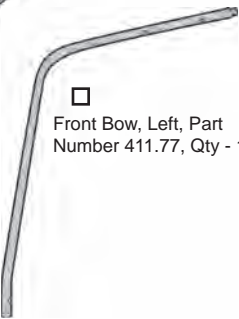

Front Bow, Left, Part Number 411.77, Qty - 1

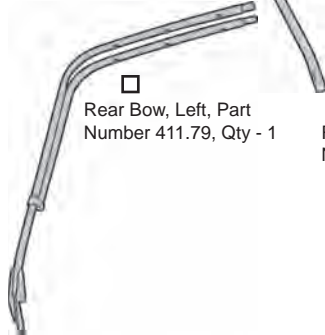

Rear Bow, Left, Part Number 411.79, Qty - 1

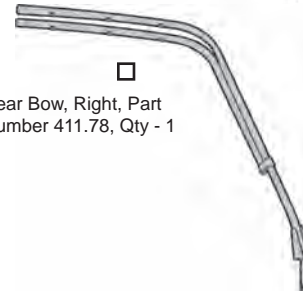

Rear Bow, Right, Part Number 411.78, Qty - 1



Tailgate Bar, Part Number 411.71, Qty - 1

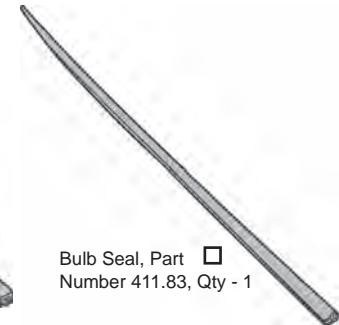

Bulb Seal, Part Number 411.83, Qty - 1



1/4" Fender Washer, Part Number 410.94, Qty - 4

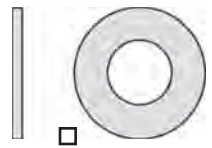

5/16" Flat Washer, Part Number 117.26, Qty - 4



1/4" x 1-1/2" Clevis Pin, Part Number 410.95, Qty - 2

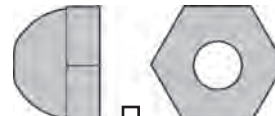

1/4-20 Cap Nut, Part Number 198.27, Qty - 10



5/16" x 3/4" Clevis Pin, Part Number 410.96, Qty - 2

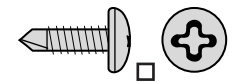

#8 x 1/2" Self Tapping Screw, Part Number 312.09, Qty - 2



1/4" Flat Washer, Part Number 21.117.10, Qty - 12



Hitch Pin Clip, Part Number 409.71, Qty - 4

# Supertop for Truck Installation Instructions

## 1 Mount Tailgate Brackets to Rear Belt Rails

Locate the Right Tailgate Bracket and the Right Rear Belt Rail in the parts kit. Place the Right Tailgate Bracket over the rear stud on the Belt Rail so that the bracket tab points away from the channel on the Belt Rail. Use a 1/4" Flat Washer and a 1/4-20 Cap Nut to secure the bracket to the rail. Repeat with the Left Tailgate Bracket and Rear Belt Rail.

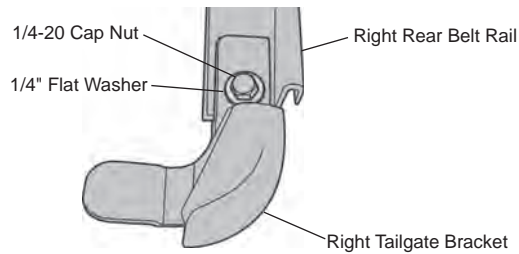

## 2 Assemble Bow Mounts Brackets

Locate the Bow Mount Brackets in the parts kit. Slide a 5/16" Flat Washer over a 5/16" x 3/4" Clevis Pin. Insert the pin through the rear pivot hole on the Bow Mount Bracket from the outside.

Slide a 1/4" Fender Washer over a 1/4" x 1-1/2" Clevis Pin and insert the pin through the front slot of the Bow Mount Bracket from the outside.

Repeat this with both Bow Mount Brackets.

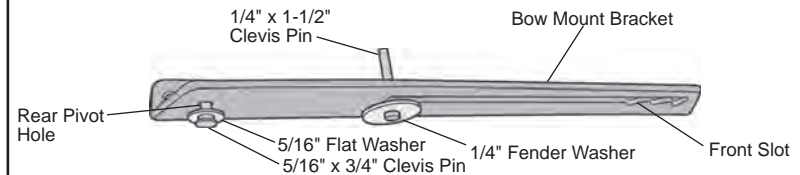

## 3 Assemble Main Bow Mount Brackets and Belt Rails

Locate the Right Front and Rear Belt Rails. Place the ends of the rails against each other. Place the Right Bow Mount Bracket on top of the Belt Rails. Secure the bracket to the rails with four (4) 1/4" Flat Washers and (4) 1/4-20 Cap Nuts. Repeat this with the Left Side Bow Mount Bracket and Belt Rails.

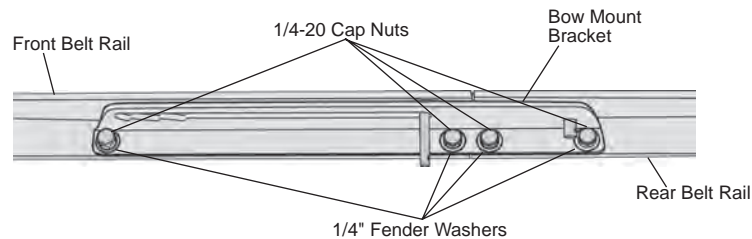

## 4 Install Foam Tape

Measure and cut a piece of Foam Tape that will fit the full length of the bottom of the Belt Rail Assembly. Peel the backing off the tape a little at a time and press the tape firmly into place on the Belt Rail Assembly. Trim the tape to match the contour of the Tailgate Bracket.

Repeat this with both Belt Rail Assemblies.

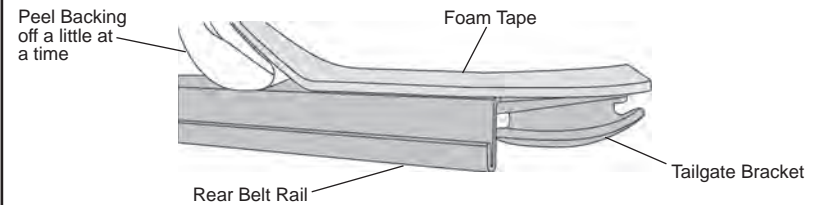

# Supertop for Truck Installation Instructions

## 5 Install Belt Rail Assemblies

Lay the Belt Rail Assemblies on top of the truck bed rail with the tab on the Tailgate Bracket toward the center of the vehicle. The front of the rail should be flush with the inside of the front wall of the truck box.

Measure the distance between the inside edges of the right and left Belt Rail Assemblies at the front and rear. Place them so that they are 57-1/4" at both places and are centered on the bed.

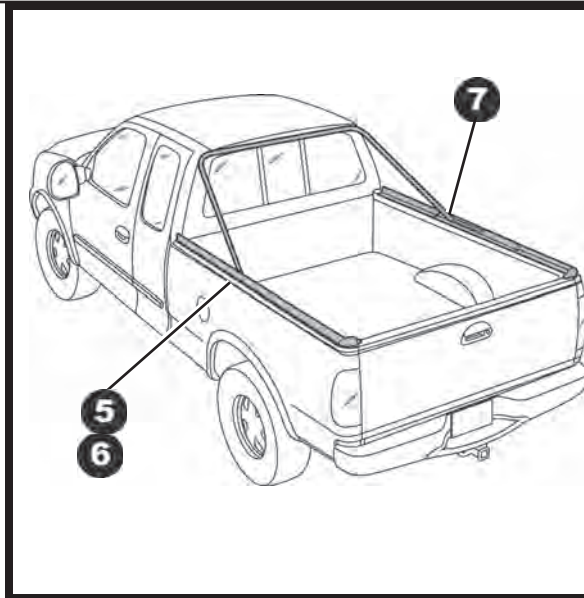
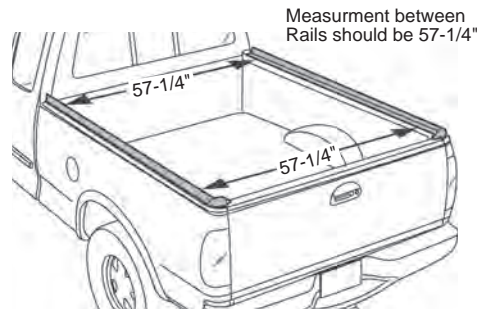
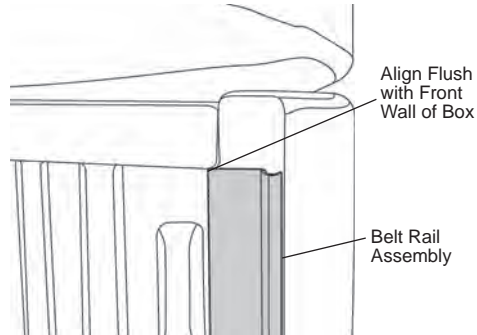

## 7 Install Front Bow

Slide a Bow Tie Down Strap onto the leg of each Front Bow half. Slide the two halves of the bow together. Place a 1/4" Fender Washer over the 1/4" x 1-1/2" Clevis Pins installed in the Bow Mounts. Slide the legs of the Front Bow Assembly over the Clevis Pins and secure them with 1/4" Flat Washer and a Hitch Pin Clip on each side of the vehicle.

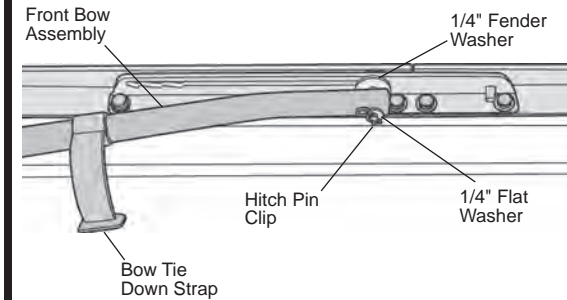

## 6 Install Belt Rail Assemblies

Locate the Clamps in the parts kit. Use two clamps to secure each Belt Rail Assembly to the vehicle. Place a Clamp 12" from each end of the Belt Rail. Fully tighten the bolt on each Clamp. Repeat this for both Belt Rail Assemblies.

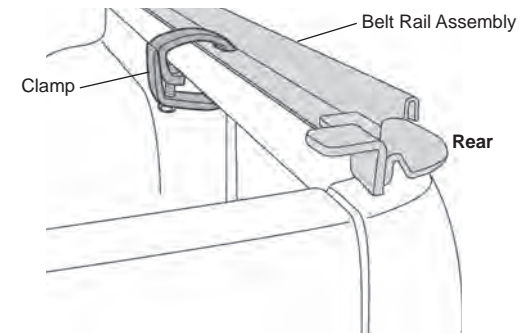



## Supertop for Truck Installation Instructions

### 8 Install Rear Bow Assembly

Locate the two (2) Elastic Garters in the parts kit. Slide a garter over each half of the Rear Bow from the center so that the Garters will hang above the rear window opening.

Slide the two (2) halves of the Rear Bow together. Slide the legs of the Rear Bow Assembly over the 5/16" x 3/4" Clevis Pins and secure them with a 5/16" Flat Washer and a Hitch Pin Clip on each side of the vehicle.

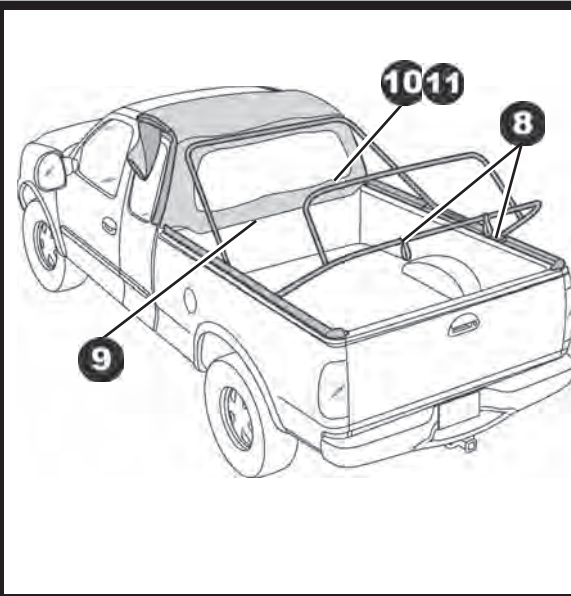
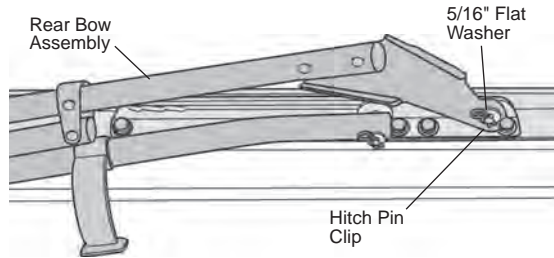

### 10 Cut Web Strap Reinforcement

Place the top fabric on a safe, clean cutting surface. Locate the two (2) wide patches in the seal below the window on the front panel of the top. Use a utility knife to cut a slit through all the layers following the indent in the seal.

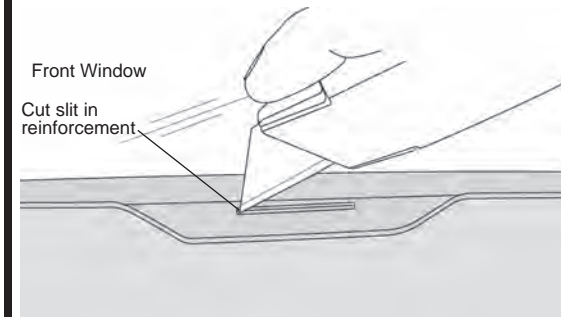

### 9 Install Adhesive Hook

Use a 50% Water/Alcohol Solution to clean the top 1-1/2" of vertical wall at the front of the truck bed. Locate the Adhesive Hook Strip in the parts kit. Peel backing tape off the hook strip 1"-2" at a time and press the hook firmly onto the vertical wall. The adhesive on the hook strip requires 72 hours to cure completely.

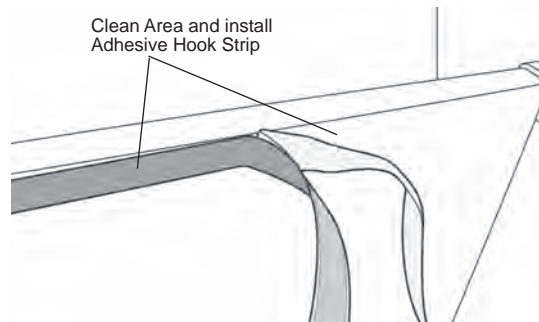

### 11 Install Buckle Straps

Locate the two (2) 32" Buckle Straps in the parts kit. Thread the end of each strap through the slits from the vinyl (outside) side of the top. Pull the straps through the slits until the back of the buckle is against the slit.

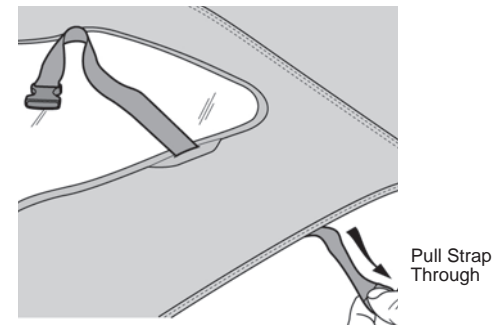

## Supertop for Truck Installation Instructions

### 12 Thread Buckles on Straps

Thread the end of the 3/2" Buckle Straps through the male half of each buckle.

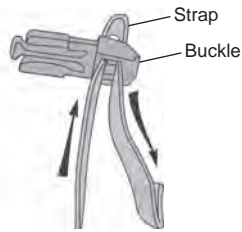

### 13 Snap Fabric to Front Bow

Drape the Supertop Fabric over the roof of the cab with the backing side up and the front window hanging down between the Front Bow and the cab of the vehicle. Locate the two snap flaps sewn to the inside of the top. Wrap the flaps around under the bow from the front and snap them to the bow.

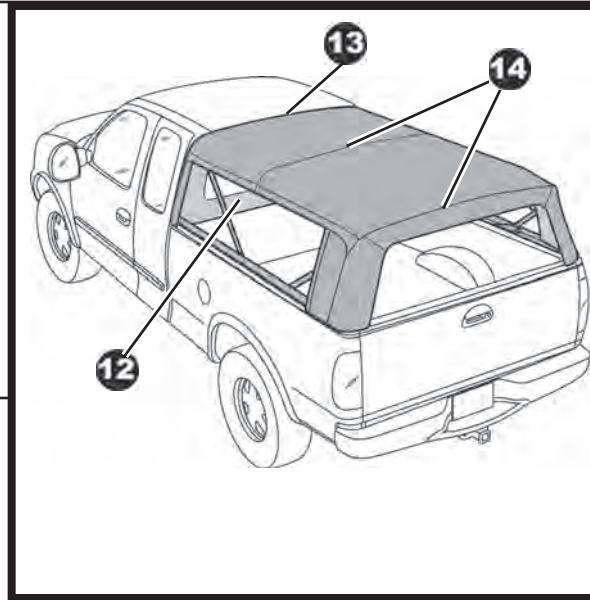
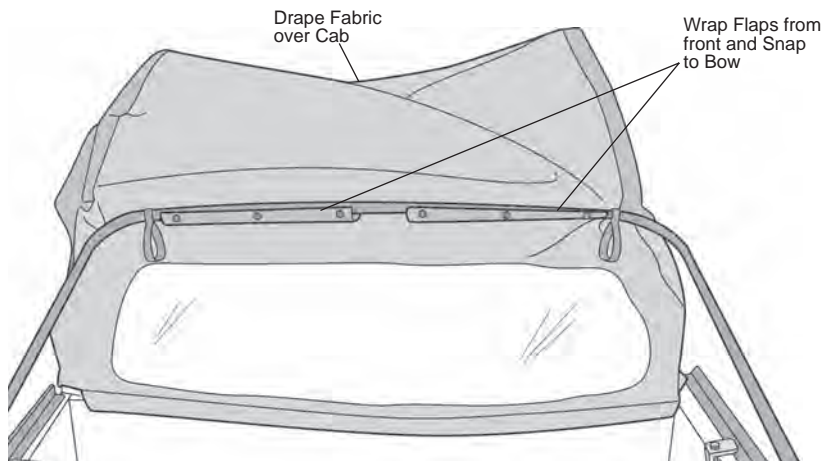

### 14 Snap Fabric to Rear and Center Bows

Carefully drape the fabric over the center and rear bows. Make sure that the sides of the top are smooth between the bows. Locate the two rear snap flaps. Wrap them around under the bow from the rear and snap them to the bow.

Then locate the six (6) snap tabs sewn to the inside of the top in the center. Wrap the two (2) center tabs and the two (2) outside tabs around the front of the bow and snap them to the bow. Wrap the remaining two (2) tabs around the rear of the bow and snap them to the bow.

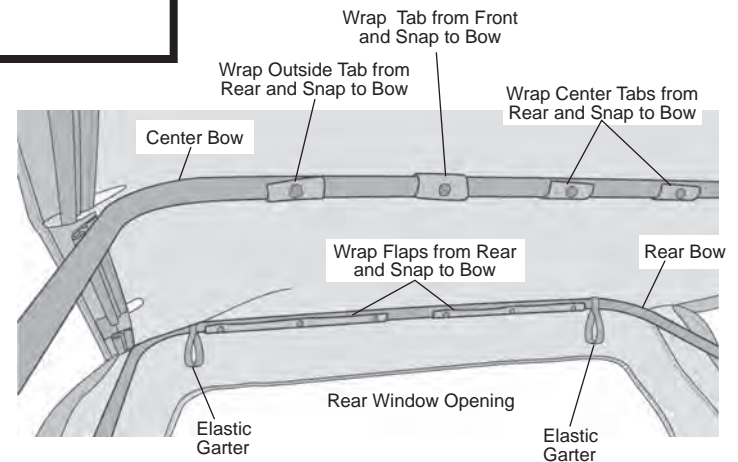

## Supertop for Truck Installation Instructions

### 15 Secure the Front of the Top

Locate the loop strip sewn to the flap along the front of the top. Fasten it to the Adhesive Hook Strip installed along the front of the bed.

#### NOTE

Do not make too many adjustments to this strip until the adhesive has completely cured, 72 hours after installation.

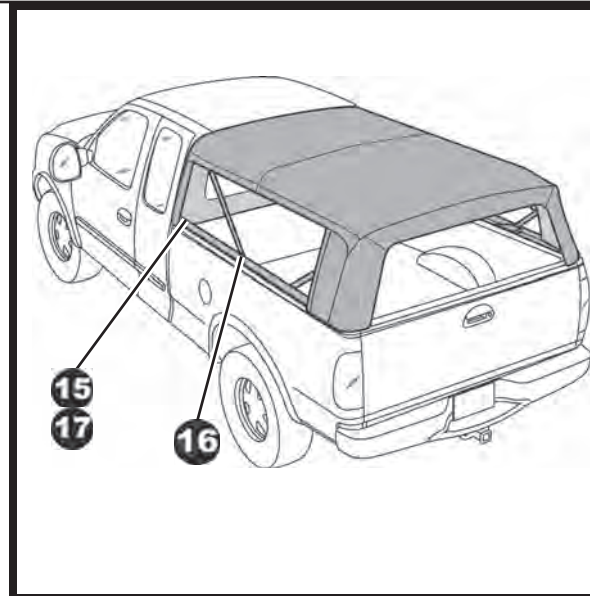
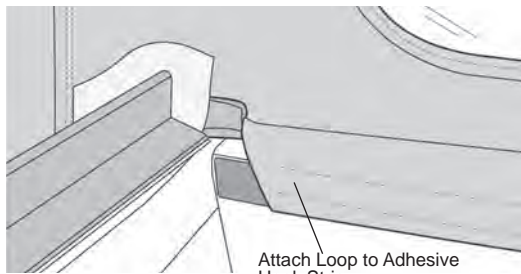

### 16 Adjust Bow Position

Place the Front Bow on the rear tooth at the front of the Bow Mount Bracket.

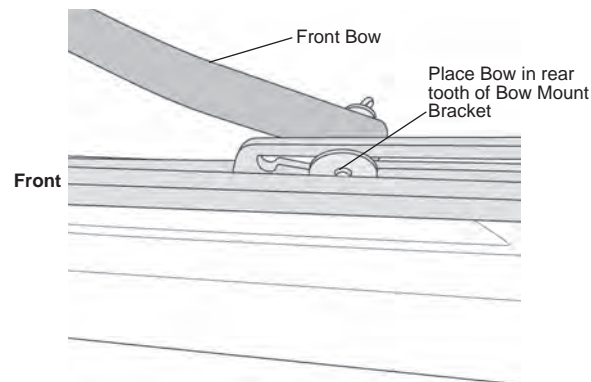

### 17 Secure the Front of the Top

Start at the front corners of the top and work the plastic strip sewn into the bottom of the panels into the channel in the Side Belt Rail. Make sure that the fabric loop sewn to the top is outside the vehicle.

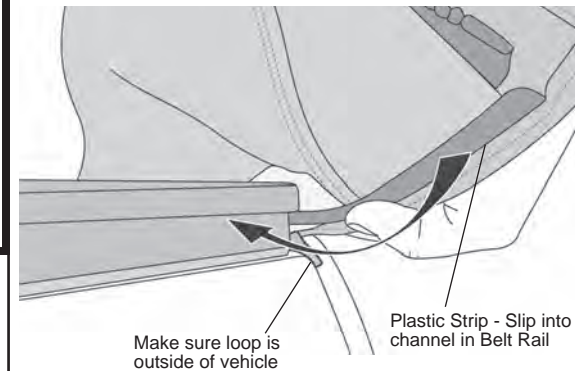

## Supertop for Truck Installation Instructions

### 18 Secure the Rear of the Top

Locate the plastic clips sewn into the rear corners of the top. Gently pull down on the rear bow and pull down and back on the fabric to hook the clips into the corner of the Tailgate Bracket on the Belt Rail Assembly. Locate the plastic strip next to the clip and hook it into the channel on the Side Belt Rail. Make sure as you do this that the corner clip remains hooked into the corner retainer.

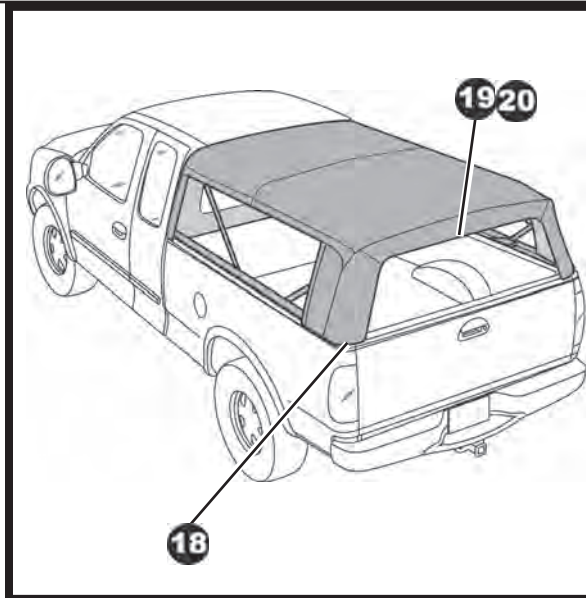
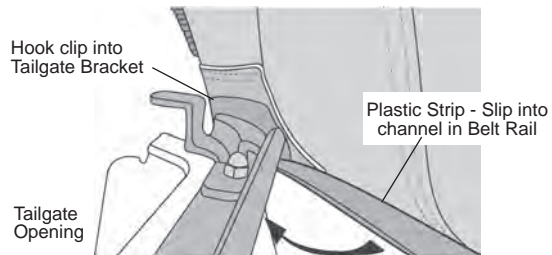

### ! WARNING

We recommend that the Third Brake Light supplied with this assembly be professionally wired.

### 20 Secure Third Brake Light to Rear Bow

Use the holes in the Third Brake Light mounting pad as a guide to center punch two holes in the Rear Bow. Drill a 0.136" hole at each of these locations. Install a #8 x 1/2" Self Tapping Screw at each of these locations.

Unsnap the snap flaps from the Rear Bow on the driver side of the brake light. Run the wire from the light along the bow and snap the flaps around the bow and the wire. Wrap the wire around the bow down to the pickup bed rail.

### 19 Install Third Brake Light

Use a 0.136" drill bit to drill out the two dimpled holes in the plastic mounting pad on the Third Brake Light. Orient the Third Brake Light so that the pad is horizontal along the Rear Bow and in the center. Peel the backing tape off the bottom of the mounting pad and press it onto the bow.

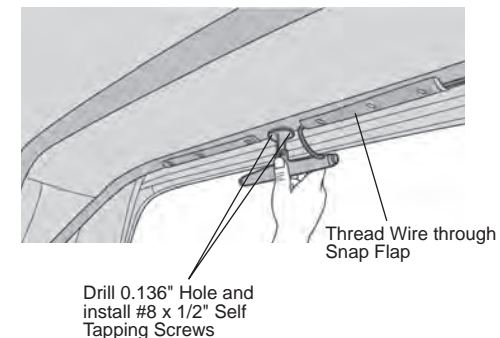
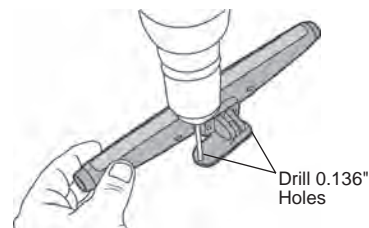
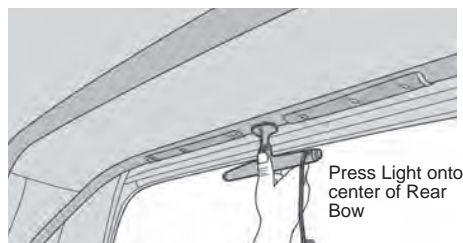



## Supertop for Truck Installation Instructions

### 21 Engage J-Hook on Rear Window

Orient the Rear Window with the plastic J-Hook toward the top.

Align the J-Hook on the top of the window with the J-Hook sewn into the top above the rear window opening. Slide them together until the Rear Window is centered in the opening.

Engage the zippers on each side of the window, but do not close them yet.

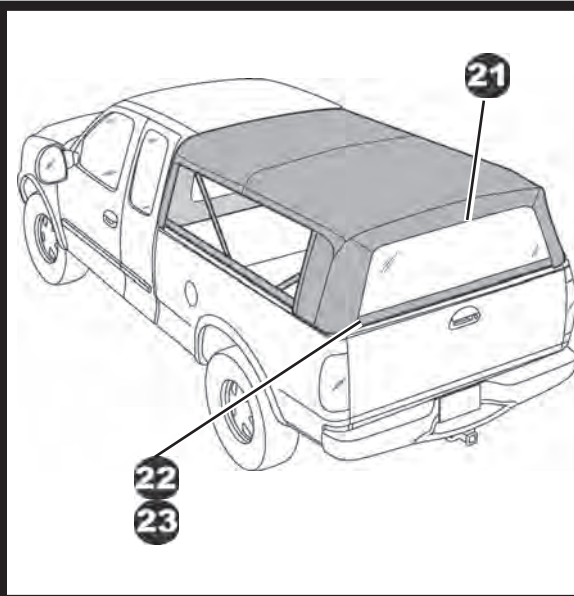
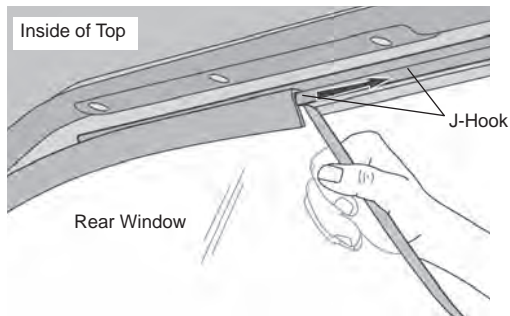

### 22 Install Bulb Seal on Tailgate Bar

Locate the Tailgate Bar and the Bulb Seal in the parts kit. Slide the channel in the Bulb Seal over the ledge on the Tailgate Bar.

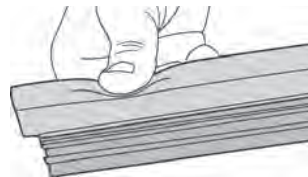

### 23 Install Tailgate Bar on Rear Window

Slide the Tailgate Bar onto the tube strip sewn to the inside of the Rear Window. Place the Tailgate Bar in the Tailgate Brackets on the Belt Rail Assemblies.

Close the zippers on each side of the window.

Close the flaps on each side of the window over the zippers and fasten the hook and loop.

Check that the tailgate closes on the Bulb Seal.

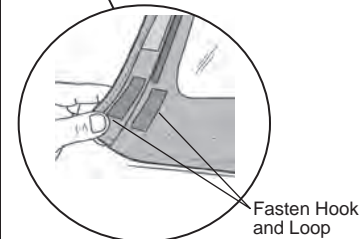
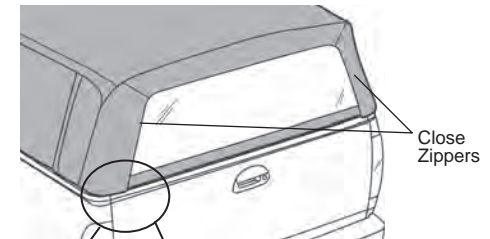

## Supertop for Truck Installation Instructions

### 24 Install Side Panels

Orient the Side Panels with the plastic J-Hook toward the top and the zipper with the flap over it toward the rear and determine which is for the driver's side of the vehicle and which is for the passenger side.

Align the J-Hook on the top of the panel with the J-Hook sewn into the top above the panel opening. Slide them together. The J-Hook in the top is in four pieces, so make sure that the J-Hook on the Side Panel stays engaged through the splits.

Engage the front and rear zippers on the panel and close them.

Work the plastic strip sewn into the bottom of the Side Panel into the channel in the Belt Rail Assembly. Fasten the Loop on the top of the Side Panel to the Hook on the deck above the opening.

Repeat this procedure for the other Side Panel.

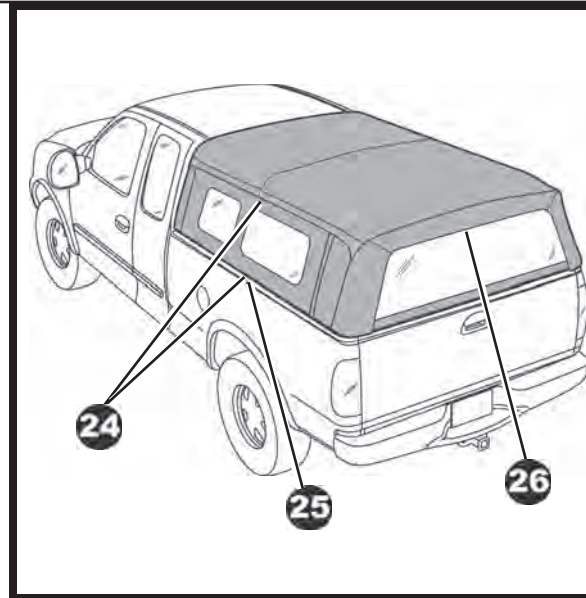

### 25 Adjust Tension on Top

It may be necessary to increase the tension on the top for a better fit. In this case, move the Front Bow forward to the next tooth in the Bow Mount Bracket.

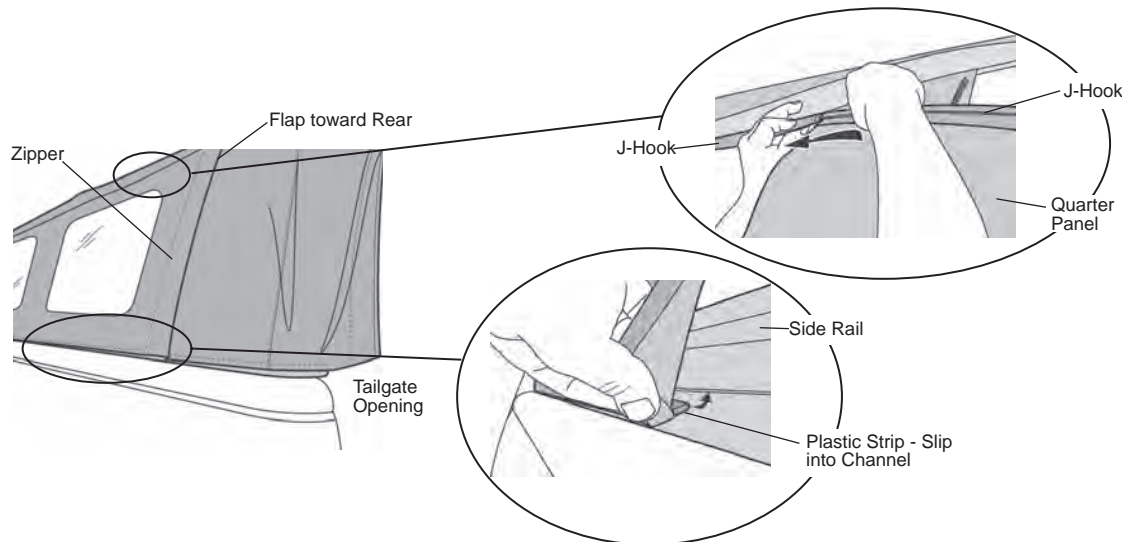
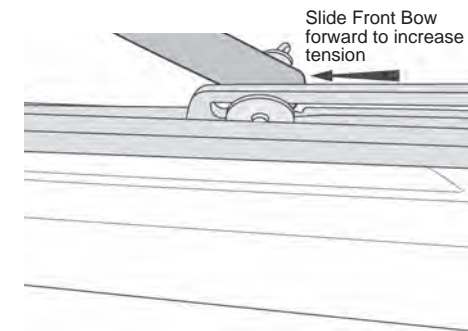

### 26 Rolling the Rear Window

Use the Elastic Garters on the Rear Bow to secure the Rear Window in the open position. Unzip the side zippers on the Rear Window and slide out the Tailgate Bar. Roll the window from the bottom to the top and wrap an Elastic Garter around each end of the window.

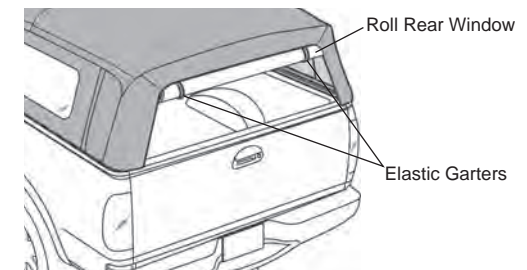

# Supertop for Truck Installation Instructions

## Collapsing the Pickup Top

### 1 Remove Windows

Remove the Side Panels and the Rear Window and store them carefully.

### 2 Release Fabric

Release the fabric from the channel in the Belt Rails.



### 3 Release the Front Bow

Move the Front Bow out of the teeth in the Bow Mount Bracket and allow the bow to collapse onto the front of the truck bed.

Fold the glass under and toward the front of the bed.

Pull the 32" Buckle Strap about halfway outside the top.

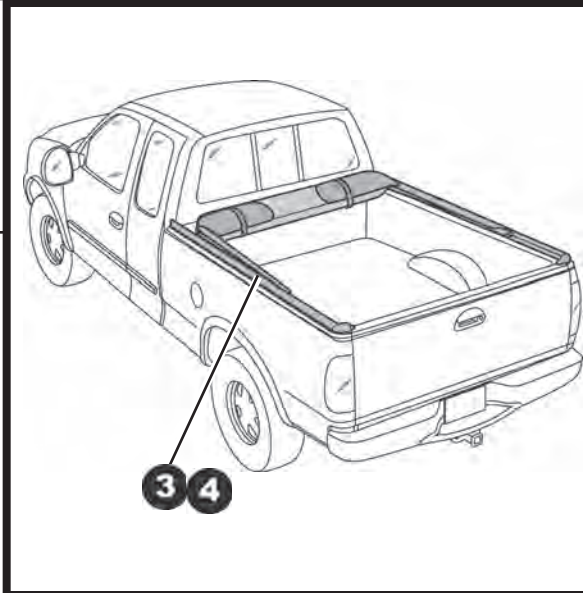
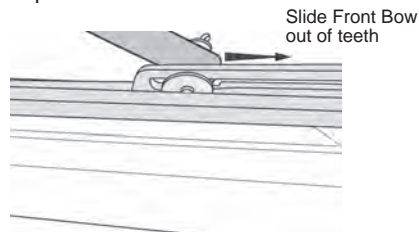

### 4 Release the Rear and Center Bows

Rotate the Rear Bow forward to collapse the Rear and Center Bows onto the Front Bow. As you are collapsing the bow assembly, make sure that the J-Hook above the side opening is folded inside the vehicle.

Fold all the J-Hook and fabric in toward the center along the front of the bed on each side.

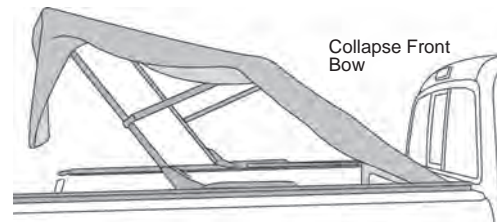
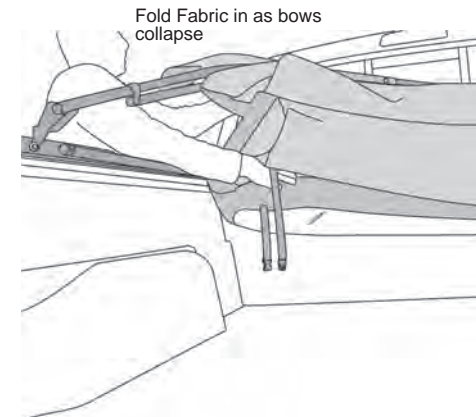

## Supertop for Truck Installation Instructions

### 5 Secure Fabric with Buckle Straps

Wrap the Buckle Straps around the fabric and the J-Hook and secure the buckles. Make sure that all the fabric is caught in the straps to keep it from flapping.

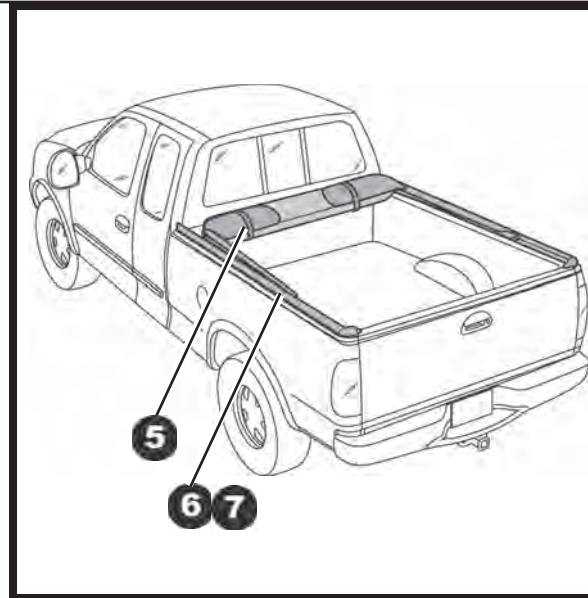

### 7 To Remove the Bow Stack

If you wish to remove the bows completely, remove the cotter pins that secure the bows to the Bow Mount Brackets.

Lift the bows off the vehicle, keeping the bows together.

Carefully store the bows and fabric.

Replace the Cotter Pins in the Bow Mount Brackets on the vehicle.

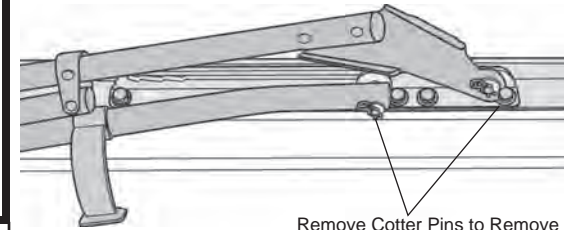

Remove Cotter Pins to Remove Bows - Then Replace Pins

### 6 Secure the Bows

Use the Tie-Down Straps on the Front Bow to secure the bow assemblies to the Belt Rail. Wrap the straps around the bows and hook the plastic strip on the end of the strap into the channel in the Side Belt Rail.

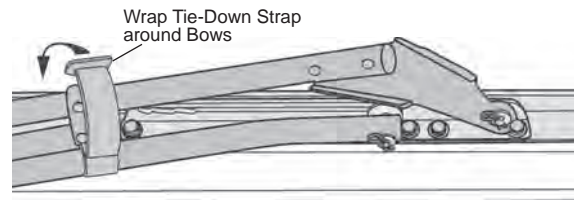

Wrap Tie-Down Strap around Bows

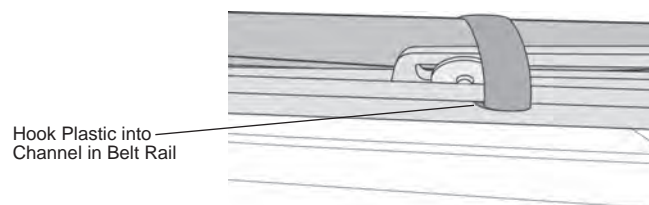

Hook Plastic into Channel in Belt Rail