



INSTALLATION INSTRUCTIONS

5536

REAR ANTI SWAY BAR DODGE DAKOTA PICKUP

Congratulations! You were selective enough to choose a BELLTECH PRODUCT. We have spent many hours developing our line of products so that you will receive maximum performance with minimum difficulty during installation.

- Note: Confirm that all of the hardware listed in the parts list is in the kit. **Do not** begin installation if any part is missing. Read the instructions thoroughly before beginning this installation.
- Warning:** **DO NOT** work under a vehicle supported by only a jack. Place support stands securely under the vehicle in the manufacturer's specified locations unless otherwise instructed.
- Warning:** **DO NOT** drive vehicle until all work has been completed and checked. Torque all hardware to values specified.
- Reminder: Proper use of safety equipment and eye/face/hand protection is absolutely necessary when using these tools to perform procedures!
- Note: It is very helpful to have an assistant available during installation.

RECOMMENDED TOOLS:

- Properly rated floor jack, support stands, and wheel chocks
- Combination wrench set
- Torque wrench: *0-75 lb ft. range*
- Ratcheting socket wrench and socket sets
- Air Chisel / Die grinder W/ cut off wheel
- Safety Glasses

KIT INSTALLATION

1. Open the hardware kit and remove all of the contents. Refer to the part list (Page 3) to verify that all parts are present.
2. Park the vehicle on a smooth level asphalt or concrete surface and set the parking brake firmly. Place a block in front of and behind the FRONT wheels. Jack up the REAR of the vehicle and place jack stands securely under the frame in the manufacturer's specified locations. Remove the rear wheels.
3. Thoroughly lubricate the inside of your new hyperthane bushings using the grease packet included with the kit. Place the bushings on the new Anti-Sway Bar. Refer to the diagram as to the proper bushing location.
4. Place the U-bolts over the axle housing (just inside of the shock mounts) and loosely fasten the Anti-Sway Bar to the bottom of the axle housing as shown in the diagram.
5. **CAUTION:** Do not place U-bolts over brake lines, as this will cause brake failure.
6. Center the Anti-Sway Bar left to right and front to rear, torque nuts to 18 ft. lbs.
7. Position ends of Anti-Sway Bar parallel with the frame rails. Position bolt through the hole in the end of the Anti-Sway Bar pointing up and mark frame rails for drilling. Drill through the bottom leg of the frame

rail using a 9/16" drill bit. **CAUTION:** Check frame rail location before drilling. Relocate any wiring or fuel lines if necessary.

8. Fasten ends of Anti-Sway bar to frame rails as shown in diagram. Tighten end link bolts until grommets bulge but **do not** crush grommets.
9. Go over the entire installation procedure and make sure all the bolts and nuts are properly torqued.

NOTE: This Anti-Sway bar fastens to the bottom of the axle housing (rear end). Arms point towards the rear of the vehicle and the ends of the Anti-Sway Bar fasten to the bottom of the frame rails. On modified trucks (i.e. lowered or lifted) different length end links may be necessary. Contact your nearest Belltech dealer for availability.

Immediately test-drive the vehicle in a remote location so that you can become accustomed to the revised driving characteristics and handling. Be aware that the vehicle will handle substantially different now that it has been modified.

REAR ANTI SWAY BAR KIT PART LIST FOR DODGE DAKOTA

PART No.	DESCRIPTION	QTY.
5536-300	Rear Anti Sway Bar	1
113000	Grommets	8
113210	Pivot Bushings 15/16"	2
114032	Bushing Brackets	2
114038	Under Support Plate	2
110255	3/8"-16 Ny Lock Nut	2
112140	3/8"-16 x 7" HHCS	2
112258	3" U-Bolt W/Nuts	2
112502	Cupped Washers Large	8
110625	3/8" Flat Washers	4
112422	Spacer Tube	2
55000-10	Grease Pack	1

! BELLTECH INSTALLATION TIPS

LUBRICATION

Pre-lubricating the inside of the bushing before it's installed is important because the lubrication will greatly reduce noise and it will increase bushing life. Belltech recommends you use Molybdenum disulfide. This will help protect the inside surface of the bushing and will last longer than most types of grease. Thoroughly lubricate the inside of the bushing with this grease.

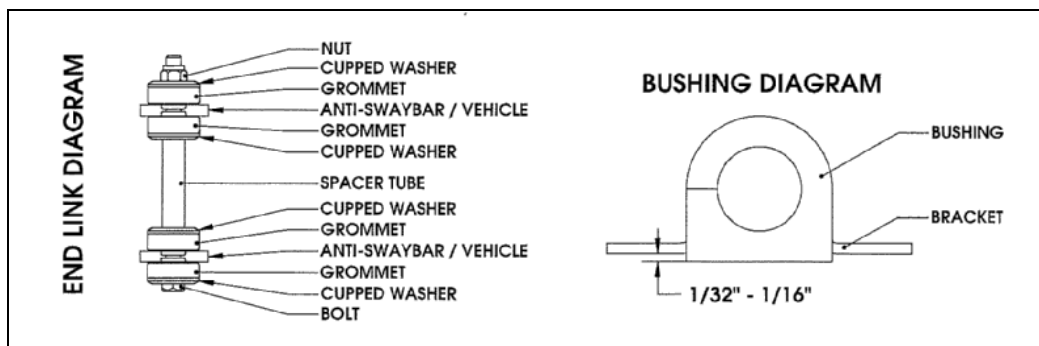

BUSHING INSTALLATION

Make sure an amount of 1/32" to 1/16" of the bushing is showing when you install it onto the bracket. See the diagram above. If the bushing is showing more than 1/16" then use a sander or a sheet of coarse grit sand paper to shave it down to the proper height. In most applications when installing the new bushings on your Belltech Anti-Sway Bar you may refer to your original equipment Anti-Sway Bar to locate the proper location.

END LINK INSTALLATION

It is not required that you use lubricant on the end links since there is not any rotational movement. The Belltech end links are comprise of grommets, cupped washers, a spacer tube, bolt, and lock nut, these assembled components create the end link. See END LINK DIAGRAM above.

AXLE CLAMP DIAGRAM

