



INSTALLATION INSTRUCTIONS

5538

REAR ANTI SWAY BAR DODGE DAKOTA

Congratulations! You were selective enough to choose a BELLTECH PRODUCT. We have spent many hours developing our line of products so that you will receive maximum performance with minimum difficulty during installation.

- Note: Confirm that all of the hardware listed in the parts list is in the kit. **Do not** begin installation if any part is missing. Read the instructions thoroughly before beginning this installation.
- Warning:** **DO NOT** work under a vehicle supported by only a jack. Place support stands securely under the vehicle in the manufacturer's specified locations unless otherwise instructed.
- Warning:** **DO NOT** drive vehicle until all work has been completed and checked. Torque all hardware to values specified.
- Reminder: Proper use of safety equipment and eye/face/hand protection is absolutely necessary when using these tools to perform procedures!
- Note: It is very helpful to have an assistant available during installation.

RECOMMENDED TOOLS:

- Properly rated floor jack, support stands, and wheel chocks
- Combination wrench set
- Torque wrench: *0-75 lb ft. range*
- Ratcheting socket wrench and socket sets
- Air Chisel / Die grinder W/ cut off wheel
- Safety Glasses

KIT INSTALLATION

1. Open the hardware kit and remove all of the contents. Refer to the part list (Page 2) to verify that all parts are present.
2. Park the vehicle on a smooth, level, asphalt or concrete surface and set the parking brake firmly. Place a block in front of and behind the FRONT wheels. Raise the REAR of the vehicle with a floor jack and place jack stands securely under the outermost part of the axle housing. Check the vehicle for stability. BELLTECH recommends the use of auto-ramps rated for the vehicle. Carefully back the vehicle onto the ramps, set the parking brake firmly, and place a block in front of and behind the front wheels.
3. Remove the original equipment rear Sway Bar and end links, if so equipped. Thoroughly lubricate the inside of your new urethane bushings using the lubricant provided in the kit. Place the lubricated bushings onto your new BELLTECH Anti-Sway Bar, just inside the 90° bends.
4. Place the U-bolts over the axle housing (just inside the shock mounts) and loosely fasten the anti-sway bar to the top of the axle housing, with the arms pointed toward the rear of the truck, as shown in diagram.

CAUTION: Do not place the U-bolts over the brake lines or else brake failure will occur.

5. Center the Anti-Sway Bar left to right and front to rear on top of the axle tube. Tighten the nuts to approximately 18 ft/lbs of torque. Position ends of the Anti-Sway Bar parallel with the frame rails. Assemble the end links to the ends of the new Anti-Sway Bar and fasten them to the existing holes in the frame rails, as shown in the diagram. (Note: Lowered vehicles will have a different end link length than stock height vehicles. See parts list.) Tighten the end link bolts until the grommets bulge but **do not** crush them.
6. Go over the entire installation procedure and make sure all appropriate fasteners are properly tight. Install the wheels if removed. Installation is complete.

Immediately test-drive the vehicle in a remote location so that you can become accustomed to the revised driving characteristics and handling. Be aware that the vehicle will handle substantially different now that it has been modified.

PART LIST FOR DODGE DAKOTA

PART No.	DESCRIPTION	QTY.
5538-001	Rear Anti Sway Bar	1
114032	Pivot Bushing Bracket	2
114038	Under Support Plate	2
113000	Grommet	8
113195	Pivot Bushing 3/4"	2
112144	3/8"-16 x 8" HHCS FOR STOCK HEIGHT	2
112130	3/8"-16 x 5-1/2" HHCS FOR LOWERED HEIGHT	2
112502	Cupped Washer Large	8
110625	Flat Washer 3/8"	8
112258	3" U-Clamp	2
110255	3/8"-16 Ny Lock Nut	6
112436	4" Spacer Tube FOR STOCK HEIGHT	2
112408	1-1/2" Spacer Tube FOR LOWERED HEIGHT	2
55000-10	Grease Pack	1
5538-886	Diagram	1

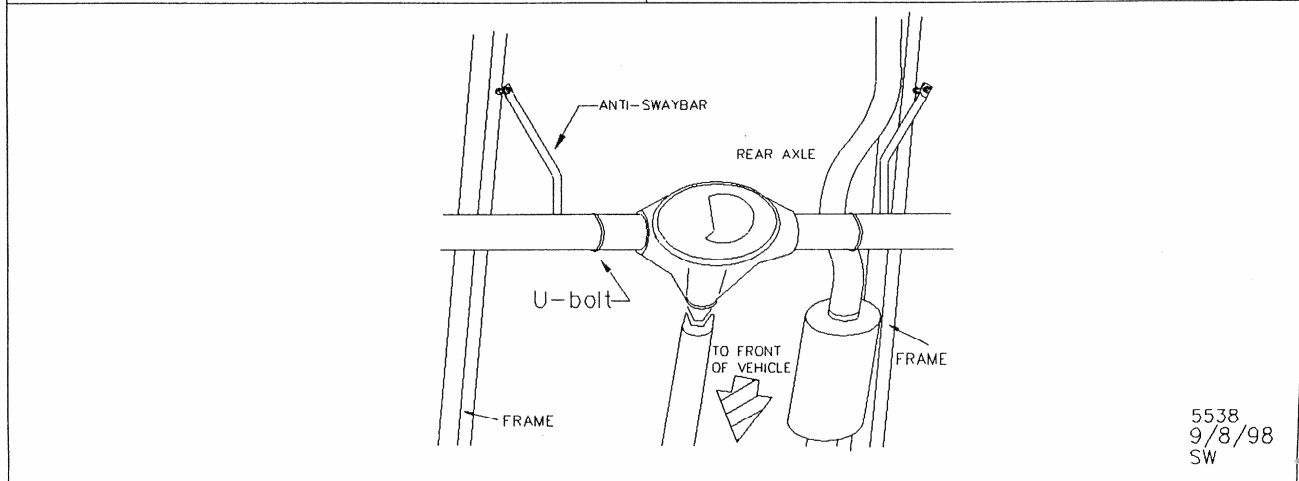
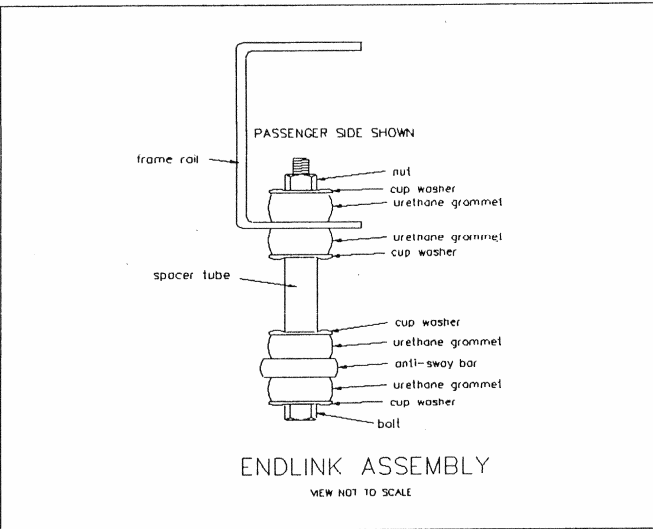
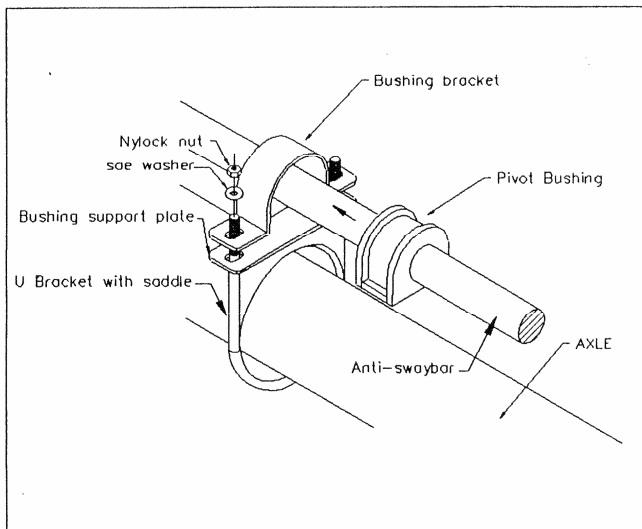

5538
 9/8/98
 SW