



INSTALLATION INSTRUCTIONS

5400

FRONT ASB

C-1500, C-2500 (6 & 8 Lug), SS454, C-3500

Congratulations! You were selective enough to choose a BELLTECH PRODUCT. We have spent many hours developing our line of products so that you will receive maximum performance with minimum difficulty during installation.

- Note: Confirm that all of the hardware listed in the parts list is in the kit. **Do not** begin installation if any part is missing. Read the instructions thoroughly before beginning this installation.
- Warning:** **DO NOT** work under a vehicle supported by only a jack. Place support stands securely under the vehicle in the manufacturer's specified locations unless otherwise instructed.
- Warning:** **DO NOT** drive vehicle until all work has been completed and checked. Torque all hardware to values specified.
- Reminder: Proper use of safety equipment and eye/face/hand protection is absolutely necessary when using these tools to perform procedures!
- Note: It is very helpful to have an assistant available during installation.

RECOMMENDED TOOLS:

- Properly rated floor jack, support stands, and wheel chocks
- Combination wrench set
- Torque wrench: *0-75 lb ft. range*
- Ratcheting socket wrench and sockets sets
- Safety Glasses

KIT INSTALLATION

1. Open the hardware kit and remove all of the contents. Refer to the part list (Page 4) to verify that all parts are present.
 2. Park the vehicle on a smooth, level concrete or seasoned asphalt surface and activate the parking brake. Block the REAR wheels of the vehicle with appropriate wheel chocks; making sure the vehicle's transmission is in 1st gear (manual) or "Park" (automatic).
 3. Using a properly rated floor jack, lift the FRONT wheels of the vehicle off the ground. Place support stands, rated for the vehicle's weight, and in the factory specified locations. Refer to the vehicle Owner's Manual. Prior to lowering the vehicle onto the stands, make sure the supports will securely contact the chassis.
- ! It is very important that the vehicle is properly supported during this installation to prevent personal injury and chassis damage! Make sure that the supports stands are properly placed prior to performing the following procedures. We **DO NOT RECOMMEND** using wheel ramps while performing this installation.
4. Slowly lower the vehicle onto the stands and, before placing the vehicle's entire weight on them, again check that they properly and securely contact the chassis as described above. Check for possible interference with any lines, wires, cables, or other easily damaged components.
 5. Park the vehicle on a smooth level asphalt or concrete surface and set the parking brake firmly. Place a block in front of and behind the rear wheels. Jack up the front of the vehicle and place jack stands

securely under the frame in the manufacturer's specified locations, check for vehicle stability and remove the front wheels.

6. Remove the end links from the ends of the original equipment Anti-Sway Bar. Remove the bushing brackets as well. Note the position of the Anti-Sway Bar in the vehicle to ease in the installation of your new Belltech Anti-Sway Bar. Remove the original equipment Anti-Sway Bar from the vehicle.
7. Thoroughly lubricate the inside of your new hyperthane bushings using the grease packet included in the kit. Place the bushing on the new Anti-Sway Bar. Refer to the original equipment Anti-Sway Bar as to the proper bushing location (Photo 1).
8. Position your new Belltech Anti-Sway Bar on the vehicle in the original equipment location and secure it with the original bushing brackets and original equipment bolts. Tighten the bolt to 28-32 ft/lbs of torque (Photo 2).

NOTE: The arms of the Anti-Sway Bar go above the tie rods.

9. Install the kit supplied end links as shown on the attached sheet. Tighten the nut on the end link bolt so only the center spacer sleeve can be rotated firmly by hand! (Photo 3). All hardware being fastened to the vehicle's original fastening points should be torqued to the proper specifications. To prevent chassis damage, never over-torque the hardware.
10. Check that all components and fasteners have been properly installed, tightened and torqued.
11. Check brake hoses, and other components for any possible interference.
12. Lift the vehicle and remove the support stands. Carefully lower the vehicle to ground.
13. Immediately test-drive the vehicle in a remote location so that you can become accustomed to the revised driving characteristics and handling. Be aware that the vehicle will handle substantially different now that it has been modified.
14. Installation is complete. Check all of the hardware and re-torque at intervals for the first 10, 100, 1000 miles.

PART LIST FOR 5400 ANTI-SWAY BAR KIT

PART No.	DESCRIPTION	QTY.
5400-300	Front ASB	1
113245	Pivot Bushing	2
113000	Grommet	8
112436	3/8" x 4" Spacers	2
110255	3/8"-16 Nylon-Lock Nuts	2
112144	3/8"-16 x 8" HHCS	2
112502	Cupped Washers	8
55000-10	Grease Pack	1

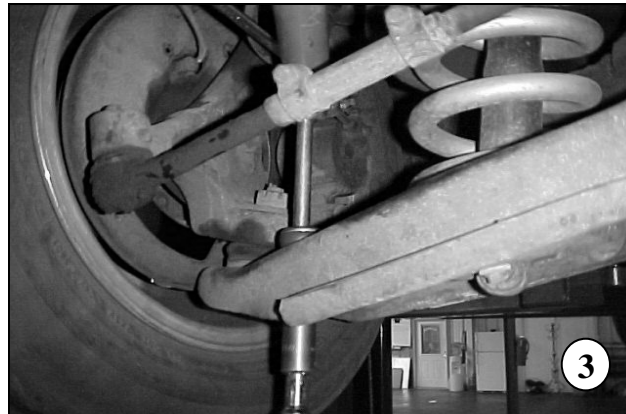
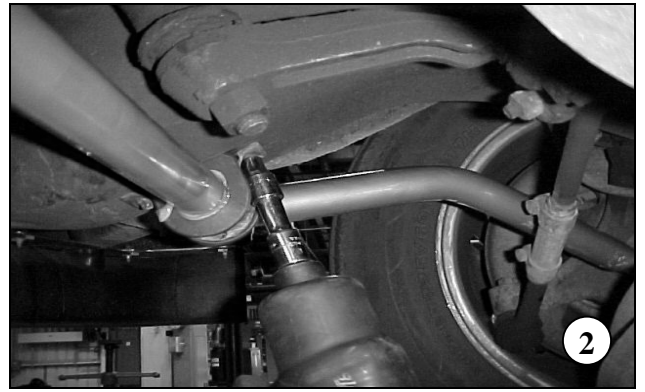

! BELLTECH INSTALLATION TIPS

LUBRICATION

Pre-lubricating the inside of the bushing before it's installed is important because the lubrication will greatly reduce noise and it will increase bushing life. Belltech recommends you use Molybdenum disulfide. This will help protect the inside surface of the bushing and will last longer than most types of grease. Thoroughly lubricate the inside of the bushing with this grease.

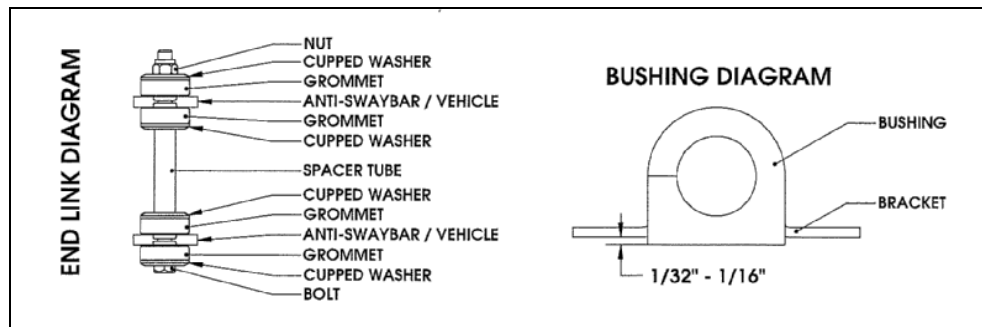

BUSHING INSTALLATION

Make sure an amount of $1/32''$ to $1/16''$ of the bushing is showing when you install it onto the bracket. See the diagram above. If the bushing is showing more than $1/16''$ then use a sander or a sheet of coarse grit sand paper to shave it down to the proper height. In most applications when installing the new bushings on your Belltech Anti-Sway Bar you may refer to your original equipment Anti-Sway Bar to locate the proper location.

END LINK INSTALLATION

It is not required that you use lubricant on the end links since there is not any rotational movement. The Belltech end links are comprise of grommets, cupped washers, a spacer tube, bolt, and lock nut, these assembled components create the end link. See END LINK DIAGRAM above.

