



INSTALLATION INSTRUCTIONS

6521

REAR AXLE FLIP & HANGER KIT – 5 OR 6 INCH LOWERING 07-13 CHEVROLET SILVERADO / GMC SIERRA 1500 ALL CABS

Thank you for being selective enough to choose our high quality BELLTECH PRODUCT. We have spent many hours developing our line of products so that you will receive maximum performance with minimum difficulty during installation.

- Note: Confirm that all of the hardware listed in the parts list is in the kit. **Do not** begin installation if any part is missing. Read the instructions thoroughly before beginning this installation.
- Warning:** **DO NOT** work under a vehicle supported by only a jack. Place support stands securely under the vehicle in the manufacturer's specified locations unless otherwise instructed.
- Warning:** **DO NOT** drive vehicle until all work has been completed and checked. Torque all hardware to values specified.
- Reminder: Proper use of safety equipment and eye/face/hand protection is absolutely necessary when using these tools to perform procedures!
- Note: It is very helpful to have an assistant available during installation.

RECOMMENDED TOOLS:

- Properly rated floor jack and six (6) support stands
- Wheel chocks
- Die grinder equipped with abrasive cut-off wheel
- ½" drive torque wrench
- Standard socket wrench set
- Air powered ½" drive impact wrench
- Flat bladed screw driver
- Safety glasses
- Air powered chisel
- Power drill and drill bits
- 3/8-16 Tap

KIT INSTALLATION

As this is a relatively involved installation, **we recommend** that a qualified mechanic at a properly equipped facility perform it. **We also recommend** that the installation be performed on a firm, flat and level surface, such as seasoned asphalt or concrete. The use of safe and properly maintained equipment is very important! **We recommend** measuring and recording all stock driveline angles prior to installing this kit. This information may be helpful if vibration problems arise after installation.

1. JACKING, SUPPORTING AND PREPARING THE VEHICLE

- 1a) Block the front wheels of the vehicle with appropriate wheel chocks. Make sure the vehicle's transmission is in "Park" (automatic) or 1st gear (manual). Activate the parking brake.
- 1b) Loosen, but **DO NOT REMOVE** the rear lug nuts.
- 1c) Lift the rear of the vehicle off the ground using a properly rated floor jack, Lift the vehicle so that the rear tires are approximately 6-8 inches off the ground surface.
- 1d) Support the vehicle using four (4) support stands, rated for the vehicle's weight. The stands should be positioned, two on each of the frame rails, just forward of the front leaf spring hangers and just below the rear leaf spring shackle hangers. Prior to lowering the vehicle onto the stands, make sure the supports will securely contact the straight, flat portions of the frame area. **It is very important that the vehicle is properly supported during this installation to prevent frame damage and personal injury! Make sure that the support stands are properly placed prior to performing the following procedures.**
- 1e) Slowly lower the vehicle onto the stands and, before placing the vehicle's weight on them, again check that they properly and securely contact the frame rails described above. Check for possible interference with any lines, wires or cables.
- 1f) Remove the rear wheels

SAFETY REMINDER: Check for safe vehicle stability before proceeding under the vehicle to begin the following procedures. Never work under a vehicle supported by only a jack. Always use properly rated support stands to support the vehicle.

2. TRAILER HITCH REMOVAL (IF APPLICABLE)

If your vehicle has come equipped with a Trailer Hitch, more than likely, this will interfere with the installation process. This will need to be removed. This makes access easier when mounting the REAR SHACKLE hardware.

- 2a) Disconnect the wire plug if it is integrated into the hitch (**Photo 1**).
- 2b) Remove all the mounting hardware for the Trailer Hitch.
- 2c) Lower and remove the Trailer Hitch and place out of the way, along with the hardware.

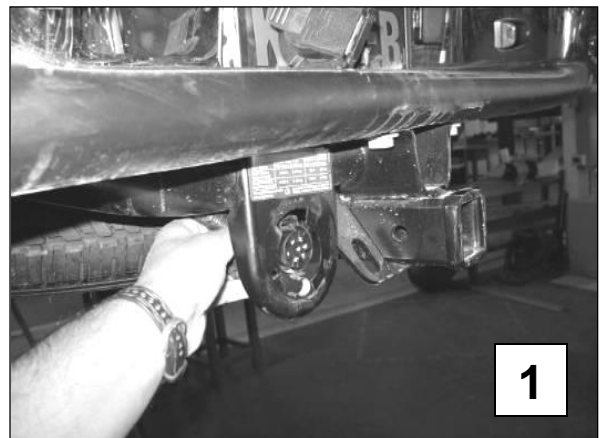

3. GAS TANK REMOVAL

NOTE: This step would be easier to do if the GAS TANK was near empty. Otherwise, moving a tank with more fuel will be more difficult.

- 3a) Remove and set aside the bolts securing the PROTECTIVE SHIELD that shrouds the GAS TANK. There are three (3) mounting bolts on one side (driver's side), that mount directly to the frame. (**Photo 2**)
- 3b) Lift the opposite side of the PROTECTIVE SHIELD up to clear the rectangular hooks (**Photo 3**). You should now be able to remove the PROTECTIVE SHIELD. Set this aside. Place the three (3) mounting bolts back in their respective mounting holes for safe keeping.
- 3c) Support the GAS TANK from underneath.
- 3d) Remove the two mounting bolts holding the GAS TANK straps that are mounted at each end of the TANK (**Photo 4**). These are located on the driver's side of the TANK itself and the inside part of the frame chassis. Each strap is mounted directly to the frame on one end only. The opposite end is attached primarily by a hook attachment.
- 3e) Pull the straps down from the driver's side and un-hook the straps from the other end
- 3f) Remove the 3 mounting bolts that secure the GAS NOZZLE INTAKE (**Photo 5**).
- 3g) Support the GAS TANK from underneath and slowly lower it six 6 to 12 inches, pulling the rubber gas neck down as the GAS TANK travels down

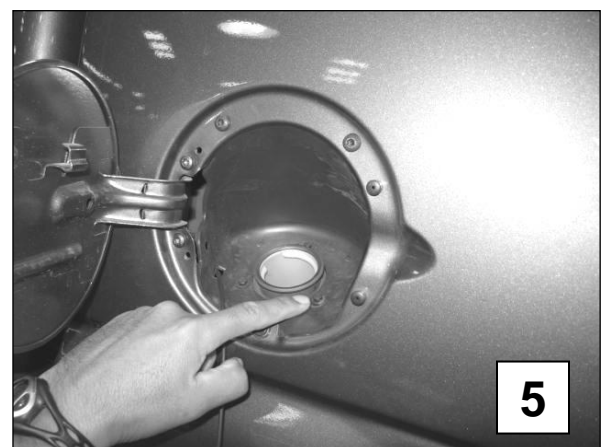
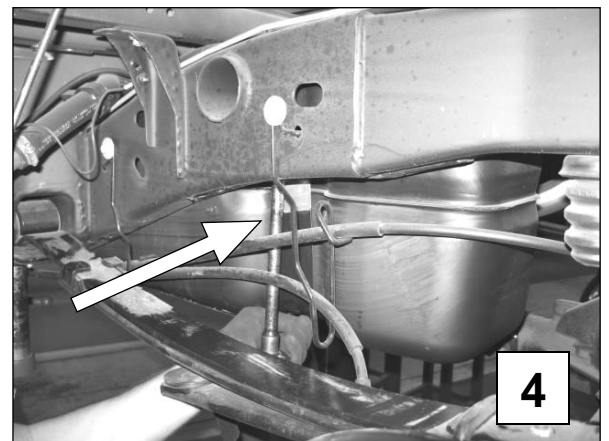
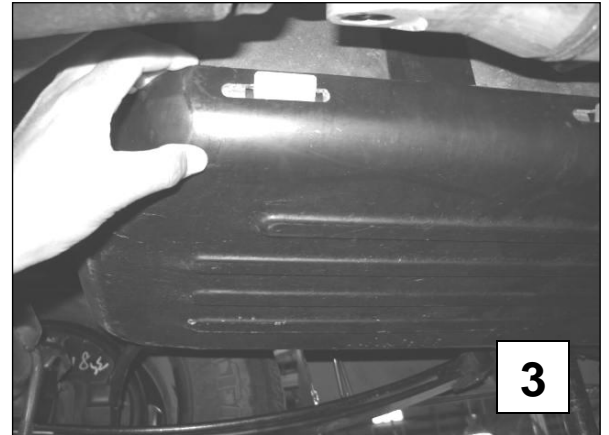
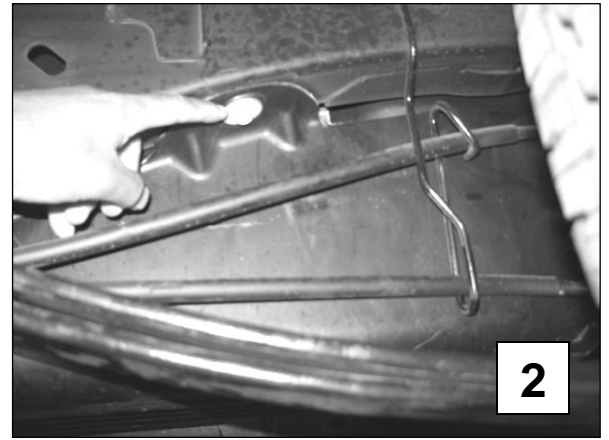

4. LEAF SPRING REMOVAL

- 4a) Remove the rear shocks
- 4b) Support the axle to keep it in place before removing the U-bolts.
- 4c) Remove the U-BOLTS (two per each LEAF SPRING) that are attached to the rear axle. Set aside all 4 stock U-BOLTS as they will be used with the new kit.

BE CAREFUL not to damage the brake hoses/and or driveline when re-locating the rear axle assembly.

- 4c) Lower the rear axle from the leaf spring and support it, making sure not to put tension on any electrical or brake lines/hoses that are attached to it.
- 4d) Remove the stock leaf spring block from the axle (**Photo 6**). The stock spring block will not be used in the Belltech kit.

CAUTION: LEAF SPRINGS may be under tension. SPRINGS under tension store a great amount of energy. Use caution during the following steps to avoid personal injury and/or damage to the vehicle.

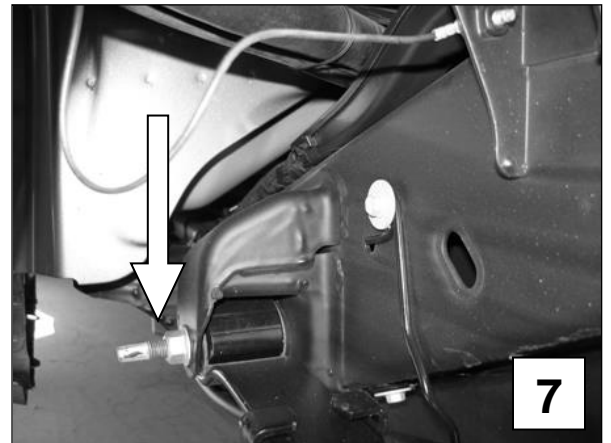
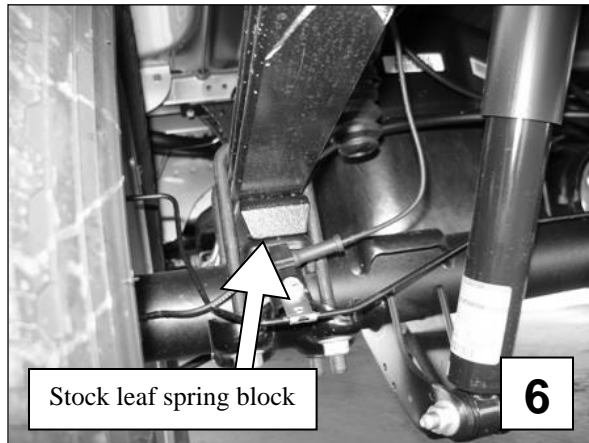

- 4e) Loosen, but do not remove the rear leaf spring mounting bolts as well as the shackle mounting bolts.
- 4f) Remove the front leaf spring mounting bolt (**Photo 7**). Once the bolt is removed, the LEAF SPRING should be able to sit atop the rear axle.

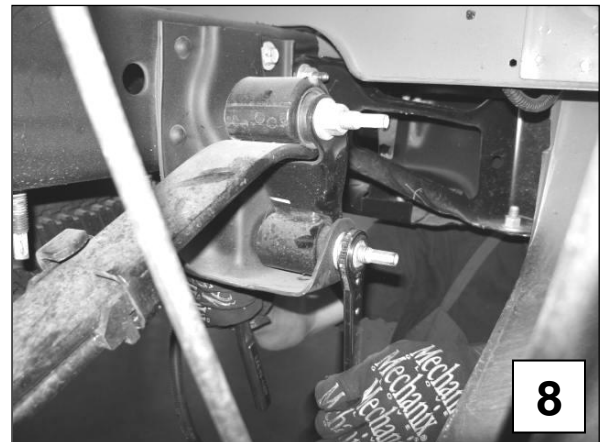

- 4g) Remove the bolts securing the rear shackle to the hanger (**Photo 8**). Carefully remove the leaf spring.

- 4h) Mark each LEAF SPRING left, right, front or rear to make sure they are re-installed correctly.

- 4i) Reverse the center bolt pin direction on both the LEAF SPRINGS for proper reinstallation after the axle is relocated. Use a c-clamp to keep the leaf spring assembly in tack while reversing the center bolt (**Photo 9**). While the center pin is removed, remove the stock U-bolt positioning bracket as it will not be used with the Belltech kit.

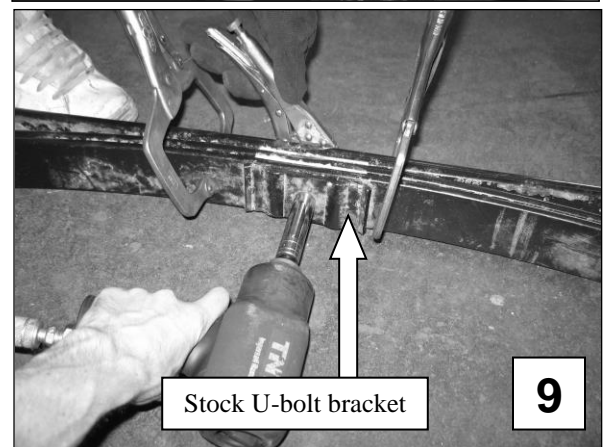

5. AXLE SADDLE PREPARATION (if applicable)

- 5a) Locate the bracket under the rear side of the stock saddle that holds the brake line and sensor wire. Detach the brake line and sensor wire from this mount and cut the mount from the axle (**Photo 10**). The new BELLTECH saddle will have an incorporated mounting surface to reattach these components.

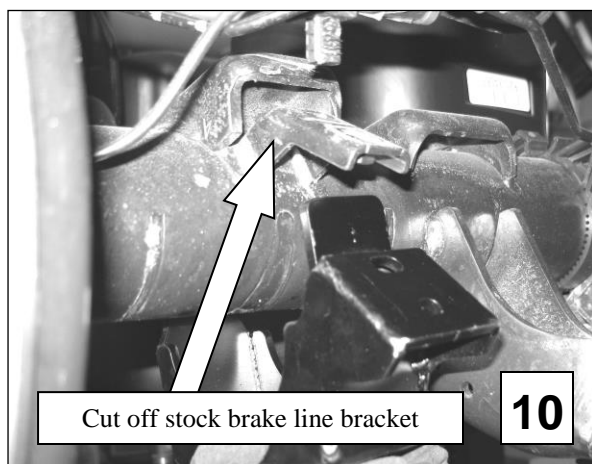

6. REAR SHACKLE HANGER REMOVAL (STOCK)

- 6a) Use a cut-off wheel or a type of abrasive cutting tool to make slots thru the heads of the rivets on each REAR SHACKLE HANGER. (**Photo 11**) There are three (3) rivets on each side that need to be removed. The slots should be straight thru the rivet heads and flush with the surface they are mounted to

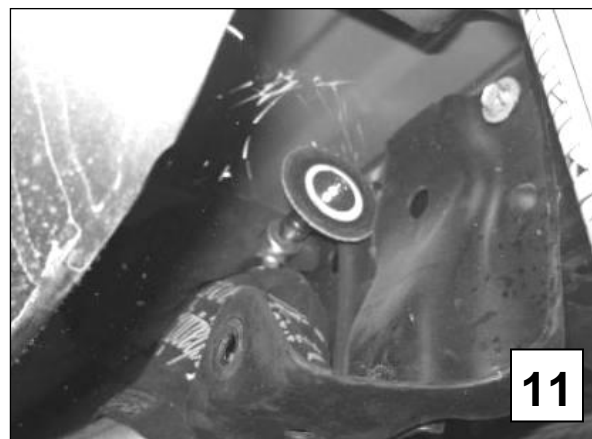

- 6b) Remove the rivet heads with a pneumatic hammer and chisel attachment. (**Photo 12**). It should take no more than a few seconds to chisel each head off. Once all rivet heads have been removed, it is helpful to use a punch and hammer or a punch with the air hammer to push out the remaining portion of the rivets.



NOTE: If the rivets heads are not easily chiseled off, the cut thru the center is probably not deep enough. Increasing the depth of the slot thru the center will decrease the time it takes to remove the rivets. DO NOT cut all the way through the hanger bracket.

- 6c) Remove the single bolt that mounts each REAR SHACKLE HANGER.

- 6d) Remove the entire REAR SHACKLE HANGER completely off the chassis.

- 6e) Remove the REAR SHACKLE HANGER SUPPORT BRACKET. Use a cut-off wheel or type of abrasive cutting tool to make a slot straight (**Photo 13**) through the rivet head and flush with surface they are mount to. Use a pneumatic hammer to remove the rivet head. The bracket is also held on by a small weld. Use a hammer and pliers to pull and push the SUPPORT

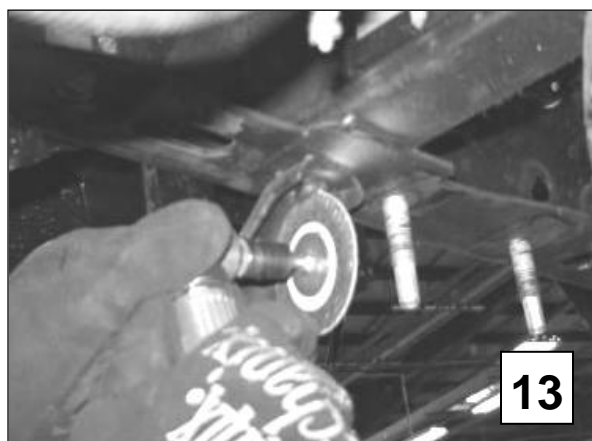

BRACKET back and forth until it breaks free. (Photo 14)

7. BUMP STOP INSTALLATION

7a) Removed the stock bump stop and bracket from the chassis to allow for additional travel (Photo 15). Unbolt the bump stock stop. To remove the bump stop mount from the chassis use an abrasive cutting wheel to cut thru the welds around the mount. **DO NOT cut into the chassis.**

7b) Use a hammer and chisel to remove the mount from the frame once the welds have been cut (Photo 16).

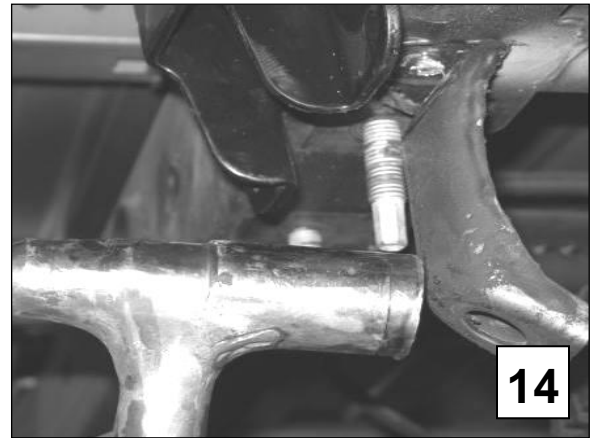

7c) Use an abrasive grinder to remove the excess material on the frame once the bracket has been removed. Use black spray paint to protect the raw exposed metal.

7d) Drill a pilot hole for the supplied bump stop. (Drill size 5/16") Locate the hole centered over the axle so the bump stop will come in contact with the bump pad on the axle (Photo 17). Tap the hole using a 3/8-16 tap.



7e) Install the BELLTECH bump stop specified for your lowering amount (See Chart A).

8. LEAF SPRING INSTALLATION

8a) Pre-assemble the REAR SHACKLE HANGER and the appropriate SPRING SHACKLE. Install but do not completely tighten the mounting bolt. (See Chart A)

8b) Using the kit supplied hardware, bolt up the new BELLTECH REAR SHACKLE HANGER to the existing holes in the chassis. (Photo 18)(See Chart A)

IMPORTANT NOTE:

Located on your new BELLTECH REAR SHACKLE HANGER, are four (4) sets of holes, four (4) on each side of the HANGER. Using the top hole and the third hole from the top, as shown in **Photo 18**, lowers the vehicle 5". For lowering the vehicle 6", use the second and fourth holes from the top. It might be necessary to bend the flange on the underside of the bed to allow for additional clearance when installing the hanger in the 6" position.



8c) Install the front of the leaf spring first using the original hardware. Install the bolt from the GAS TANK side outward towards the driver's side of the vehicle, thru the frame and the LEAF SPRING eye. Start the lock nut, but do not tighten completely. (**Photo 19**)

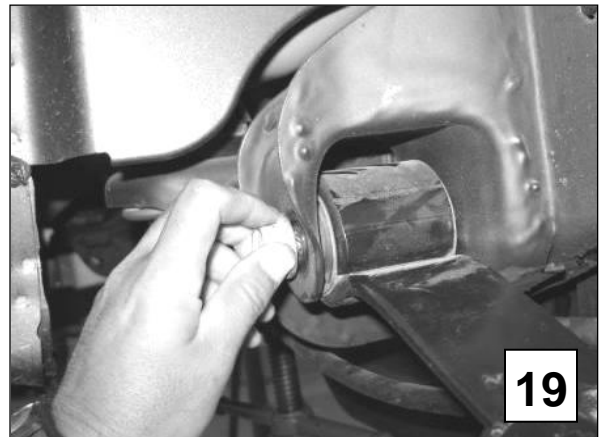

8d) Raise the rear axle up far enough to attach the rear leaf spring mount. Swing the LEAF SPRING upward. The LEAF SPRING will now locate underneath the rear axle.

8e) Align the LEAF SPRING eye with the SPRING SHACKLE mount holes. Insert the hardware and but do not tighten completely (**Photo 20**).

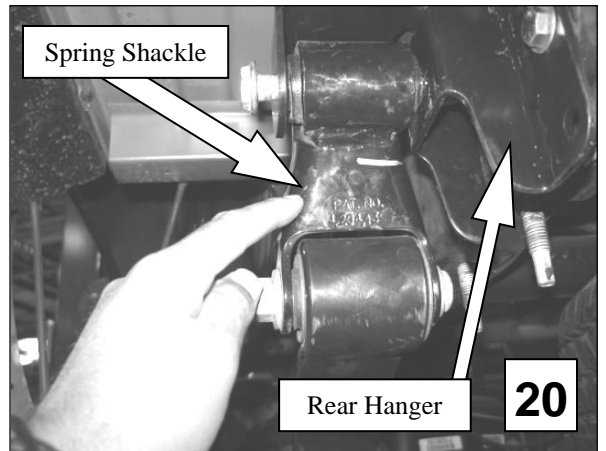

8f) Tighten the front LEAF SPRING mounting bolts.

8g) Re-install gas tank, nozzle, and cover, making sure not to damage any hoses or fittings when reinstalling.

9. AXLE SADDLE AND U-BOLT INSTALLATION

9a) Place the BELLTECH ADAPTER SADDLES on top of the springs with the hole over the head of the spring center bolt. To properly position the axle, the attached mounting plate for the brake line and sensor wire (If Applicable) will face the rear of the vehicle.

- 9b)** Lower the rear axle assembly down onto the saddles slowly. The ears should fit into the stock spring perches on the axle tubes. Make sure both ears on each SADDLE locate completely in the perches
- 9c)** Place the BELLTECH U-BOLT SPRING PAD MOUNTS on top of the axle spring pad and with the stock U-bolts place the horizontal portion inside the two bent flanges so they are locked in position (**Photo 21**).

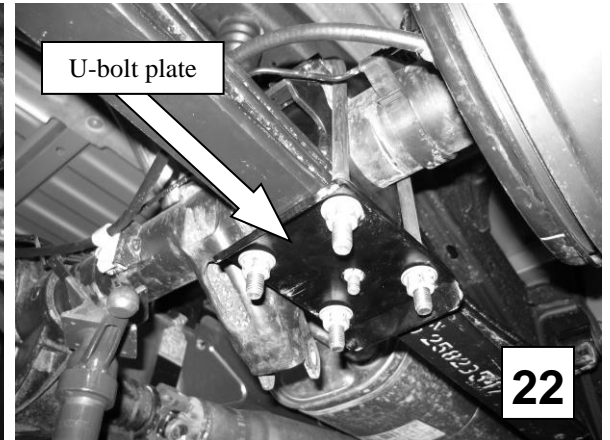
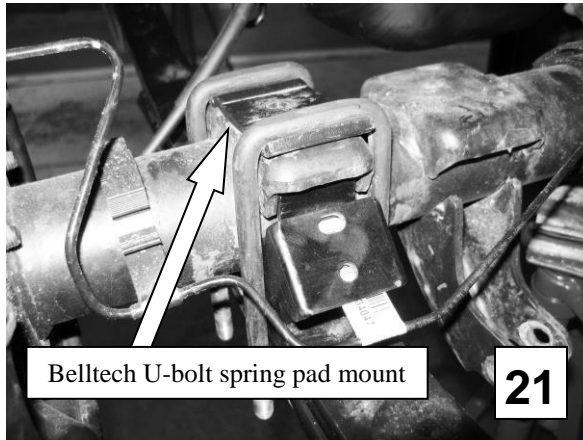

- 9d)** Install the BELLTECH U-BOLT PLATES (under the LEAF SPRINGS), with the off-set holes forward, so the U-BOLTS pass through the appropriate slots. (**Photo 22**) Attach the PLATES using washers and locknuts. Tighten and torque locknuts to 90 ft./lb.

Note: The BELLTECH AXLE ADAPTER SADDLES have been designed to properly position the rear axle pinion shaft relative to the driveline so that vibrations are eliminated. If driveline vibrations are experienced, take the vehicle to a driveline service shop immediately for driveline angle inspection and necessary adjustments. **DO NOT** drive vehicles exhibiting driveline vibrations, as U-joint wear could occur prematurely. Be sure to lubricate the U-joints if deemed necessary. For 2012 & 2013 Extended and Crew Cab models, pinion shim kits are available. For 5" or 6" lowering please use Belltech **Part# 4976**. For the 4" lowered applications please use Belltech **Part# 4977**. Insert the pinion shims between the ADAPTER SADDLES and the leaf spring. Pinion shims should be positioned with the larger end of the shim towards the **REAR** of the vehicle. The leaf spring center bolt pin should be located in the hole of the shim rather than the slot.

- 9e)** Install all brake line and electrical brackets
- 9f)** Install trailer hitch and wiring.
- 9g)** Install Belltech shocks (**See Chart A**)

10. 2WD TRANSMISSION SPACER INSTALLATION

We have included a transmission spacer to correct a small drive line vibration. The spacer will install between the transmission mount and the rubber isolator (**Photo 23**).

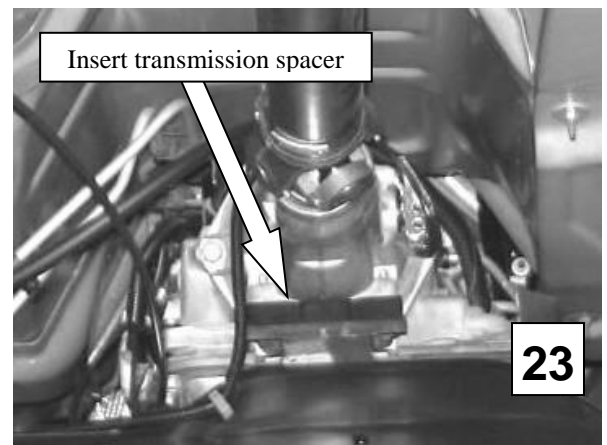

- 10a)** Remove the two bolts from the isolator to the transmission, lift and insert the spacer, install the two supplied 10mm bolts thru the spacer and back into the transmission.

11. 4WD TRANSMISSION SPACER INSTALLATION

11a) Remove transfer case cover(**Photo 24**)

11b) Remove the two nuts holding the transmission isolator to the crossmember(**Photo 25**)



11c) Place jack stand under transfer case and raise the transmission approx. 1" (**Photo 26**). This will allow you to remove the 2 bolts attached to the transmission.(**Photo 27 & 28**)

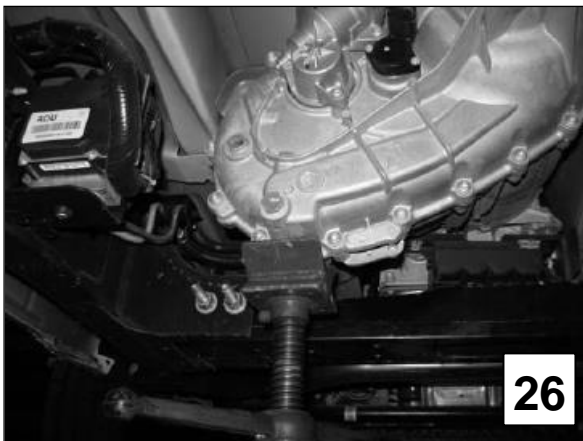

11d) Insert the BELLTECH Transmission spacers supplied, 2 per side. Re-attach the isolator to the transmission with the supplied hardware. (**Photo 29**)

11e) Lower the Transmission isolator bracket back into place and re-attach using stock hardware.

12. COMPLETING INSTALLATION

- 12a)** All hardware being fastened to the vehicle's original fastening points should be torqued to the proper specifications. To prevent chassis damage, never over-torque the hardware. The SPRING SHACKLE MOUNTS should remain installed but not tightened until step 12e.
- 12b)** Check that all components have been properly installed, tightened and torqued.
- 12c)** Reinstall the rear wheels.
- 12d)** Lift vehicle and remove support stands. Carefully lower vehicle to ground.
- 12e)** Tighten all 4 SPRING SHACKLE bolts to 90 ft./lbs.
- 12f)** Immediately test-drive the vehicle in a remote location so that you can become accustomed to the revised driving characteristics and handling. Be aware that the vehicle will handle substantially different now that it has been modified
- 12g)** Installation is complete. Check all of the hardware and re-torque at intervals for the first 10, 100, 1000 miles.

Parts List: 6521 Axle flip kit

Part #	Description	Quantity
6521-020	Axle Saddle	2
6521-005	U-Bolt Plate	2
6521-004	U-Bolt Spring Pad Mount	2
6519-010	Rear Leaf Hanger	2
6521-003	Transmission Spacer	1
5922-001	1 ¼" Bump Stop	2
110645	Flat Washer A325 7/16" (Hanger)	12
110303	Stover Lock Nut 7/16"-20 (Hanger)	6
110650	HH Cap Screw 7/16"-20 X 1-1/4" (Hanger)	6
112002	HHCS 8mm-1.25 x 20 (Axle Saddle)	2
112280	Flange Nut 8mm x 1.25 (Axle Saddle)	2
112026	HHCS 10mm-1.5 x 35mm (Transmission Spacer)	2
110625	Flat Washer 3/8" (Axle Saddle)	2

Chart A - Installation Chart For Each Lowering

<u>Application</u>	<u>Spring Shackle</u>	<u>Hanger Position On Vehicle</u>	<u>Bump Stop</u>	<u>Shocks</u> Street Performance / Nitro Drop 2
4" drop	Belltech (6700)	Lowest	2" (4923)	2212FF / 8504
5" drop	Stock	Lowest	1 ¼" (5922)	2210FF / 8510
6" drop	Stock	Highest	1 ¼" (5922)	2210FF / 8510



INSTALLATION INSTRUCTIONS

6400, 6401, 6403, 6404, 6405, 6406, 6425, 6590, 6700, 6702 Lowering Shackles

Congratulations! You were selective enough to choose a BELLTECH PRODUCT. We have spent many hours developing our line of products so that you will receive maximum performance with minimum difficulty during installation.

Note: Confirm that all of the hardware listed in the parts list is in the kit. **Do not** begin installation if any part is missing. Read the instructions thoroughly before beginning this installation.

Warning: **DO NOT** work under a vehicle supported by only a jack. Place support stands securely under the vehicle in the manufacturer's specified locations unless otherwise instructed.

Warning: **DO NOT** drive vehicle until all work has been completed and checked. Torque all hardware to values specified.

Reminder: Proper use of safety equipment and eye/face/hand protection is absolutely necessary when using these tools to perform procedures!

Note: It is very helpful to have an assistant available during installation.

RECOMMENDED TOOLS:

- Properly rated floor jack, support stands, and wheel chocks
- Combination wrench set
- Torque wrench: *50-250 lb ft. range*
- Ratcheting socket wrench and socket sets
- Safety Glasses

JACKING, SUPPORTING AND PREPARING THE VEHICLE

1. Open the hardware kit and remove all of the contents. Refer to the part list (Page 3) to verify that all parts are present.
2. Park the vehicle on a smooth, level concrete or seasoned asphalt surface and activate the parking brake. Block the FRONT wheels of the vehicle with appropriate wheel chocks; making sure the vehicle's transmission is in 1st gear (manual) or "Park" (automatic).
3. Using a properly rated floor jack, lift the REAR wheels of the vehicle off the ground. Place support stands, rated for the vehicle's weight, and in the factory specified locations. Refer to the vehicle Owner's Manual. Prior to lowering the vehicle onto the stands, make sure the supports will securely contact the chassis.

It is very important that the vehicle is properly supported during this installation to prevent personal injury and chassis damage! Make sure that the supports stands are properly placed prior to performing the following procedures. We **DO NOT RECOMMEND** using wheel ramps while performing this installation.

4. Slowly lower the vehicle onto the stands and, before placing the vehicle's entire weight on them, again check that they properly and securely contact the chassis as described above.

5. Check for possible interference with any lines, wires, cables, or other easily damaged components.

SHACKLE INSTALLATION

1. Block the front wheel and raise the back of the truck. Place jack stands under the frame just ahead of the front spring hangers.
2. Position the rear end with a floor jack so there is no pressure on the leaf springs at the rear shackles. Remove the spring eyebolts from the shackle and remove it from the leaf spring. **CAUTION:** Leaf springs are under tension, use caution when disconnecting. (Photo 1 & 2)
3. Lift the rear of the spring up and place the new shackle on the spring. Make sure you put the spring eyebolt in from the inside out so the threads are toward the outside. (Photo 2)
4. Lower the shackle into position, into the stock hanger on the frame and slide the spring eyebolt through the spring into place. (Photo 3) Raise the truck with the floor jack just until the truck lifts off the stands. Now tighten the four spring eyebolts on the shackles. Remove the jack stands carefully and lower the truck to the ground. Your installation is now complete.

All hardware being fastened to the vehicle's original fastening points should be torqued to the proper specifications. To prevent chassis damage, never over-torque the hardware.

6. Check that all components and fasteners have been properly installed, tightened and torqued.
7. Check brake hoses, and other components for any possible interference.
8. Lift vehicle and remove support stands. Carefully lower vehicle to ground.
9. Immediately test-drive the vehicle in a remote location so that you can become accustomed to the revised driving characteristics and handling. Be aware that the vehicle will handle substantially different now that it has been modified.
10. Installation is complete. Check all of the hardware and re-torque at intervals for the first 10, 100, 1000 miles.

SPECIAL INSTRUCTIONS

For the 6406 shackles

- When installing the 6406 shackles you must fold the bed flange to one side or trim the flange for adequate shackle clearance (Photo 4).
- It is helpful to bolt the shackle to the hanger and swing it thru its range of motion to see where the flange needs to be modified.

PART LIST FOR LOWERING SHACKLE KITS and/or SPACERS KITS

Part Number	Description	Qty
6400-100	2" Lowering Shackle	2
6403-100	3" Lowering Shackle	2
6404-100	1/2" Lifting Shackle	2
6405-100	1" Lowering Shackle	2
6406-100	2" Lowering Shackle	2
6425-010	2" Lowering Shackle	2
6590-010	2" Lowering Shackle	2
6700-100	1" Lowering Shackle	2
6702-100	Shackle	2
6401	Shackle & Spacer	2/8

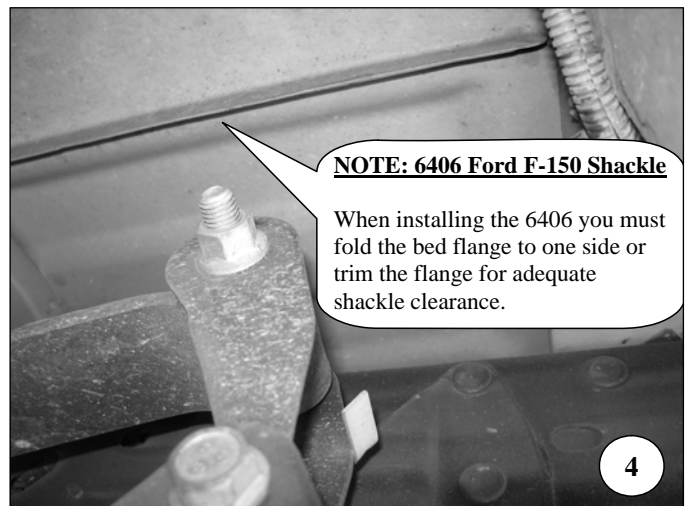
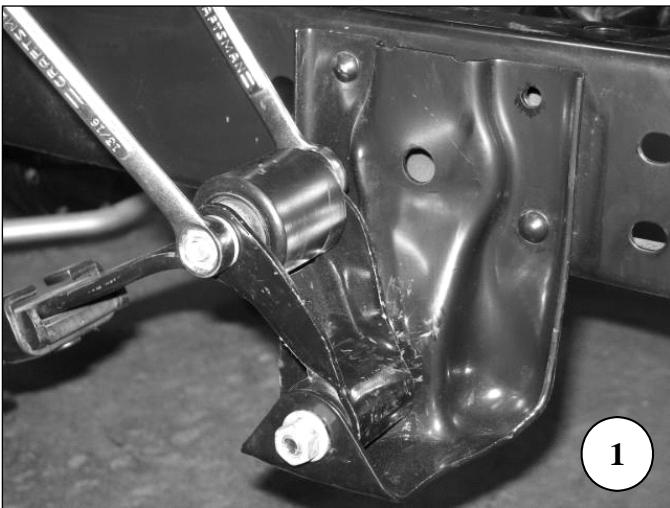

SPECIAL INSTRUCTIONS

For the 6401 SPACERS

- When installing the 6401 SPACERS, simply loosen the four (4) ubolt nuts, remove the top spacer block, add the four (4) new spacers, re attach the four (4) nuts. Torque to manufacturers specifications. See photos below.



TOP SPACER BLOCK



NEW SPACERS



INSTALLATION INSTRUCTIONS

4955 FRONT CAMBER BUSHINGS GMC 2WD/4WD

Congratulations! You were selective enough to choose a BELLTECH PRODUCT. We have spent many hours developing our line of products so that you will receive maximum performance with minimum difficulty during installation.

- Note:** Confirm that all of the hardware listed in the parts list is in the kit. **Do not** begin installation if any part is missing. Read the instructions thoroughly before beginning this installation.
- Warning:** **DO NOT** work under a vehicle supported by only a jack. Place support stands securely under the vehicle in the manufacturer's specified locations unless otherwise instructed.
- Warning:** **DO NOT** drive vehicle until all work has been completed and checked. Torque all hardware to values specified.
- Warning:** This install **requires specialty tools** and should be taken to an alignment shop for proper installation
- Reminder:** Proper use of safety equipment and eye/face/hand protection is absolutely necessary when using these tools to perform procedures!
- Note:** It is very helpful to have an assistant available during installation.

RECOMMENDED TOOLS:

- Properly rated floor jack, support stands, and wheel chocks
- Combination wrench set
- Torque wrench: *0-300 lb ft. range*
- Ratcheting socket wrench and sockets sets
- Safety Glasses
- Bushing press with GM bushing adapters.

KIT INSTALLATION

1. Open the hardware kit and remove all of the contents. Refer to the part list (**Page 3**) to verify that all parts are present.
 2. Park the vehicle on a smooth, level concrete or seasoned asphalt surface and activate the parking brake. Block the REAR wheels of the vehicle with appropriate wheel chocks; making sure the vehicle's transmission is in 1st gear (manual) or "Park" (automatic). Using a properly rated floor jack, lift the front wheels of the vehicle off the ground. Place support stands, rated for the vehicle's weight, in the factory specified locations. Refer to the vehicle Owner's Manual. Prior to lowering the vehicle onto the stands, make sure the supports will securely contact the chassis.
- !** It is very important that the vehicle is properly supported during this installation to prevent personal injury and chassis damage! Make sure that the support stands are properly placed prior to performing the following procedures. We **DO NOT RECOMMEND** using wheel ramps while performing this installation. Slowly lower the vehicle onto the stands and, before placing the vehicles entire weight on them, again check that they properly and securely contact the chassis as described above. Check for possible interference with any lines, wires, cables, or other easily damaged components.

1. STEERING KNUCKLE REMOVAL

- a) Remove wheel assembly.
- b) Remove upper control arm from vehicle using manufacture's recommended procedure. Follow all safety precautions.

The follow steps require special bushing press equipment and should only be performed by a professional with such equipment.

- c) With upper control properly supported in a vise, push the OEM bushings out with the proper tools.
- d) Install the new Belltech bushings into the upper control arm where the OEM bushings were removed with arrow reference notches pointing away from the ball joint in line with the control arm. Failure to follow this may result in poor handling and premature bushing wear.

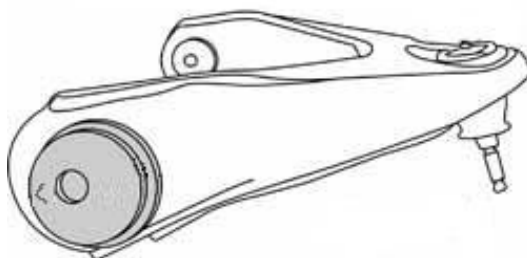

- e) For **1999-2006** vehicles the distance between the two inner faces of the bushings should be $9\frac{7}{8}$ ". Make sure the bushings are centered in the arm.

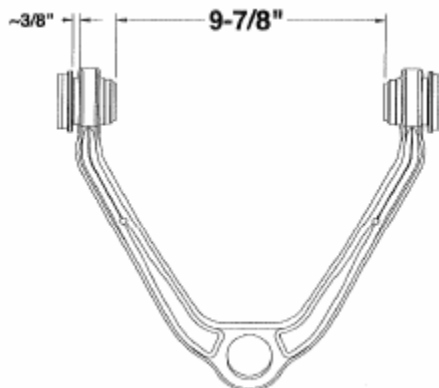

- f) For **2007 up** vehicles the distance between the two inner faces of the bushings should be 9. Make sure the bushings are centered in the arm.

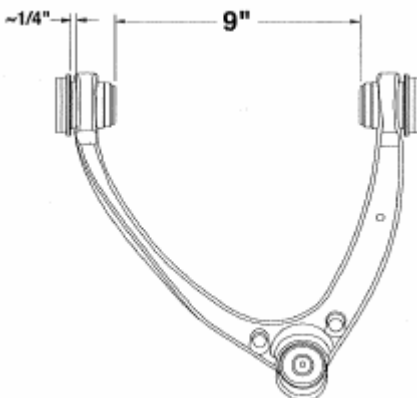

- g)** Reinstall upper control arm using manufacturer's recommended procedure.
- h)** Reinstall wheel assembly and torque wheel lugs to manufacturer's recommended specifications.
- i)** Reset vehicle alignment to manufacturer's recommended specifications.
- j)** Road test vehicle.

PART LIST FOR 4955 FRONT CAMBER BUSHINGS

PART#	DESCRIPTION	QTY
4955-001	FRONT CAMBER BUSHINGS	4



INSTALLATION INSTRUCTIONS

STREET PERFORMANCE & NITRO DROP 2 SHOCKS

Congratulations! You were selective enough to choose a BELLTECH PRODUCT.

Belltech Shocks for truck suspensions are designed for easy installation. If not otherwise stipulated in these instructions, all suspension components are installed and removed in accordance with the manufacturer's specifications for installing and removing standard damper components.

Construction Lube

When you install your Belltech Street Performance or Nitro Drop 2 Shock you may notice a slight oil drip down the side. **The shock is not leaking.** This is oil lubrication used in the construction assembly of the shock. Simply wipe the oil off with a damp cloth.

Nitro Drop 2 Shocks

Your Nitro Drop 2 Shock is a low pressure oil shock. If the shock is compressed the rod will not return to an extended position on its own. ***The shock's performance relies on the internal Belltech valving technology which is not affected by the relative pressure of the shock.***

Pin Bushings

Your Belltech Street Performance or Nitro Drop 2 Shocks may be fitted with a Pin Bushing. If so it is necessary to properly fit the bushing to your vehicle by choosing the correct notch on the Pin Bushing.

1. Remove OE shock from vehicle.
2. Examine OE pin bushing and measure diameter of notch.
3. Compare to the 2 different notch sizes on the top and bottom of the supplied Belltech Pin Bushing and use the notch that most closely matches your OE pin bushing.

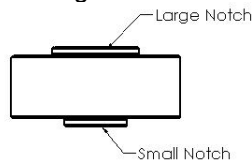

4. Install the shock with the selected notch sandwiching the shock mount of the vehicle.

Dust Cover

Your Belltech Street Performance Shocks may be fitted with a removable dust cover. Some vehicle applications may require you to remove the dust cover for more clearance.



1. Check vehicle to see if there is enough clearance for dust cover. If there is not enough clearance, remove the dust cover by removing the pin bushings and washers and then remove the dust cover.
2. Install included 10mm (0.39in), part number 112445, dust cover spacer.



3. Install washer and bottom pin bushing, with selected notch facing up (see Pin Bushing section, above), then install on vehicle with top pin bushing, with selected notch facing down (see Pin Bushing section, above) and washer.



INSTALLATION INSTRUCTIONS

15002/16002

COILOVER

2007-2018 CHEVROLET SILVERADO (2WD/4WD) (-1" TO -3")

Thank you for being selective enough to choose our high quality BELLTECH PRODUCT. We have spent many hours developing our line of products so that you will receive maximum performance with minimum difficulty during installation.

Note: Confirm that all hardware listed in the parts list is in the kit. **DO NOT** begin this installation if any part is missing. Read the instructions thoroughly before beginning this installation.

Warning: DO NOT work under a vehicle supported by only a jack. Place support stands securely under the vehicle in the manufacturer's specified locations unless otherwise instructed.

Warning: DO NOT drive the vehicle until all work has been completed and checked. Torque all hardware to values specified.

Reminder: Proper use of safety equipment and eye/face/hand protection is necessary when using these tools to perform procedures!

Note: It is very helpful to have an assistant available during the installation process.

Note: We **DO NOT RECOMMEND** using wheel ramps while performing this installation.

Note: **On some vehicles when using the full 2" drop it might not be possible to get the vehicle into OE camber specifications. In this case it may be necessary to purchase Belltech 1° camber cams (part #: 4951) or Belltech 2° upper control arm bushings (part #: 4955)**

RECOMMENDED TOOLS:

- Blocks and Wheel chocks
- Ratcheting Socket Wrench
- Safety Glasses
- Floor jack and Jack Stands
- Torque Wrench 10-75 lb ft. range
- Properly rated floor jacks and support stands
- Combination Wrench
- Torque wrench: 0-75 lb ft. range

1. KIT INSTALLATION

1a. Open the hardware kit and remove all contents. Refer to the parts list (Page 8) to verify that all parts are present.

1b. Park the vehicle on a smooth, level concrete or seasoned asphalt surface and activate the parking brake. Block the REAR wheels of the vehicle with appropriate wheel chocks; making sure the vehicle's transmission is in 1st gear (manual) or "Park" (automatic).

1c. Using a properly rated floor jack, lift the FRONT wheels of the vehicle off the ground. Please use support stands, rated for the vehicle's weight and in the factory specified locations. Refer to the vehicle Owner's Manual. Prior to lowering the vehicle onto the stands, make sure the supports will securely contact the chassis.

1d. It is very important that the vehicle is properly supported during this installation to prevent personal injury and chassis damage. Make sure that the support stands are properly placed prior to performing the following procedures. We **DO NOT RECOMMEND** using wheel ramps while performing this installation.

2. REMOVING THE O.E.M. FRONT STRUT

2a. Locate the top three mount bolts of the front spring/strut assembly.

2b. Remove all three mounting nuts that attaches the top of the spring/strut assembly to the chassis (**Photo 1**)

2c. Remove the two bottom mounting nuts of the spring/strut assembly (**Photo 2**)



2d. Remove the mount nuts from the end links. Remove the end links completely (**Photo 3**)

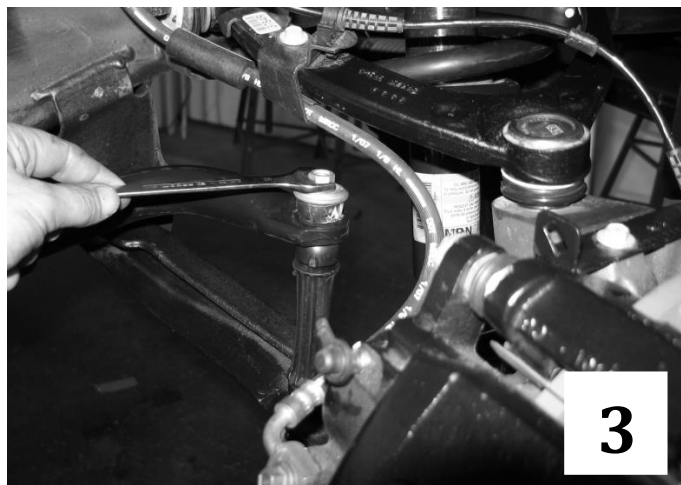

2e. Once all mounts have been un-bolted, hold the spindle assembly while slightly pushing down, dislodging the bottom spring/strut assembly from its bottom mounts releasing the entire spring/strut assembly from the Strut tower. **(Photo 4)**

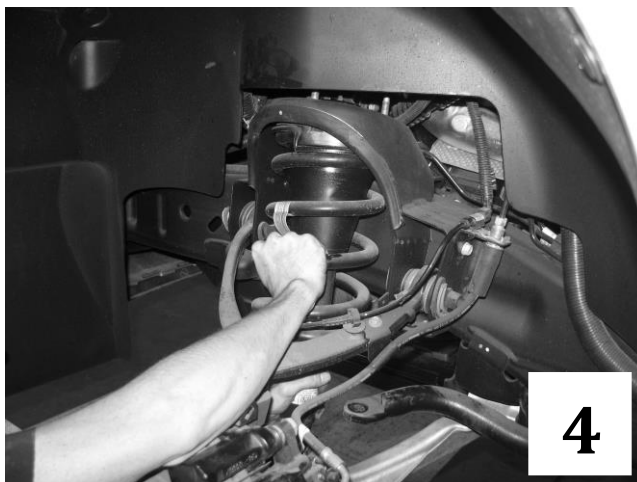

Coil springs may be under tension. Springs under tension store a great amount of energy. Use caution during the following steps to avoid personal injury and/or damage to vehicle. Be careful not to damage the brake hoses.

3. COILOVER HEIGHT SETUP

- a. Refer to the chart below to determine the “A” measurement to set the drop desired from OEM (Factory Height)

Caution: The chart below is designed to use the Belltech 15002/16002 pre-assembled coilover out of the box. This is, an out of the box, lowering solution. Belltech does not recommend lowering beyond what is advertised in the chart below as the performance of the shock may be greatly decreased.

- b. Using the spanner wrench provided in the kit, turn the bottom of the spring perch (685-10-039) clock-wise to obtain the “A” measurement that is desired.

NOTE: IT IS RECOMMENDED TO PRESET THE “A” MEASUREMNT AT A HIGHER SETTING AND ADJUST DOWN, CLOCKWISE, TO THE DESIRED VEHICLE HEIGHT ONCE THE COILOVER IS INSTALLED

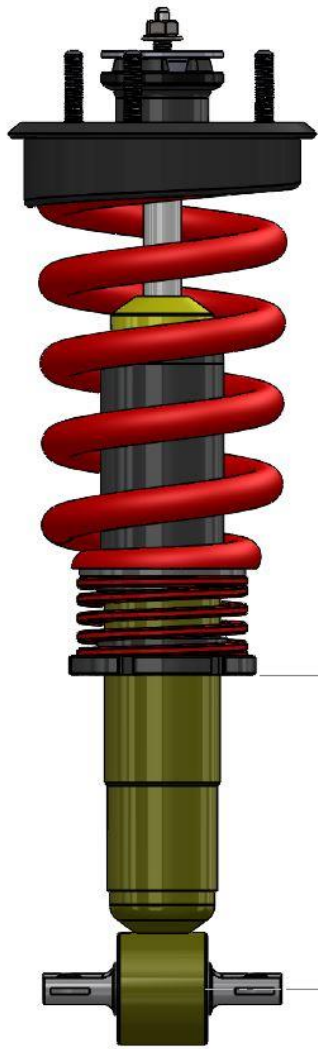

"A" MEASUREMENT	HUB TO FENDER (DESIRED DROP FROM OEM)
186 mm	25.4 mm (1.0 inch)
178 mm	38.1 mm (1.5 inch)
170 mm	50.8 mm (2.0 inch)
162 mm	63.5 mm (2.5 inch)
154 mm	76.2 mm (3.0 inch)

!! FOR BELLTECH KIT (16002) ONLY, PLEASE READ BELOW!!

THE DAMPER COMES PRE-ADJUSTED (REBOUND & COMPRESSION) PLEASE USE THE SUPPLIED ADJUSTMENT KNOB (PART #: 685-25-101) TO ADJUST THE REBOUND VALVE, SEE FIGURE (1A). ADJUST THE BOTTOM COMPRESSION VALVE BY TURNING THE BOTTOM BUILT-IN KNOB CLOCKWISE OR COUNTER-CLOCKWISE. (FIGURE 2A)

CAUTION: MAKING CHANGES TO THE REBOUND AND COMPRESSION VALVES WILL CREATE CHANGES IN THE VEHICLES DRIVING CHARACTERISTICS. PLEASE ADJUST ALL SETTINGS SAFELY AND GET FAMILIAR WITH THE NEW DRIVING STYLE OF THE VEHICLE.

REBOUND	<i>6 CLICKS</i>	<i>OPEN</i>	COMPRESSION	<i>6 CLICKS</i>	<i>OPEN</i>
----------------	-----------------	-------------	--------------------	-----------------	-------------

All adjustments will be done based on a closed valve (max. hard). The closed valve can be reached by turning the adjustment wheel completely to hard (+)..

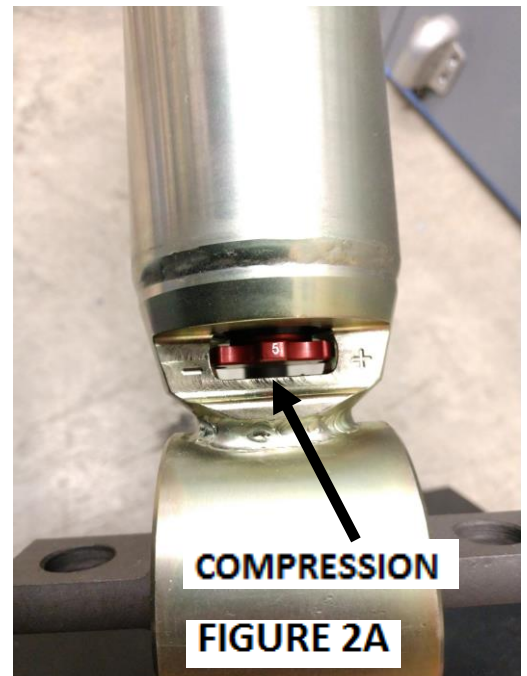
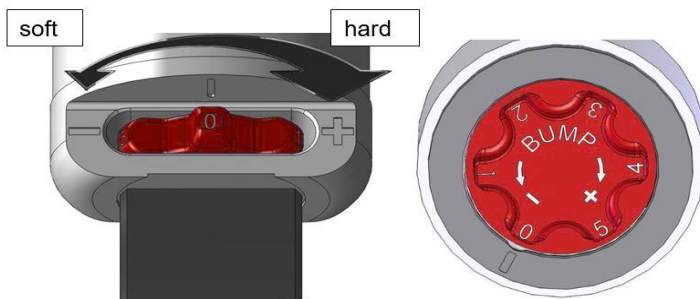
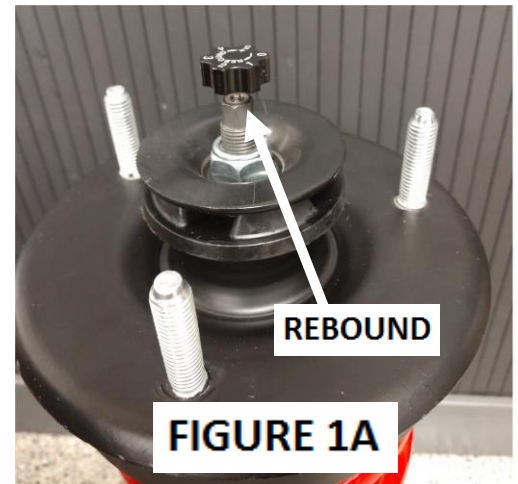

BUMP STOP PREPERATION

The Bump stop should be cut at the location seen in picture Figure 3A. Use the 35mm (longer) height bump stop for lowering range between 1"-1.5". For any lowering range past 2" please use the 20mm (shorter) bump stop portion.

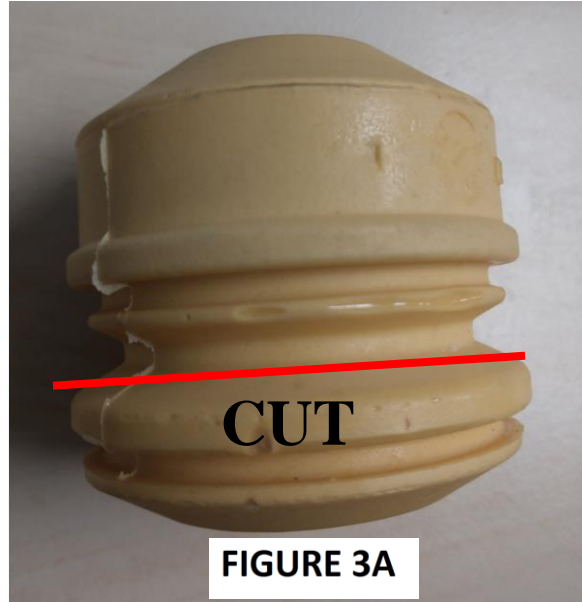

INSTALLING COILOVER ASSEMBLY

5a. Re-install on the new assembly in reverse order of disassembly. (Steps 2e-2a) You will re-use the OEM nut clips to install the new BELLTECH COILOVER.

Note it may be necessary to unbolt the upper control arm from the spindle to fit the strut into the mounted position. If this is necessary, remove the upper ball joint nut from the spindle and disconnect the ball joint from the spindle. Install the Belltech strut following Step 5B. Reinstall the upper ball joint to the spindle and tighten all the fasteners to factory specifications.

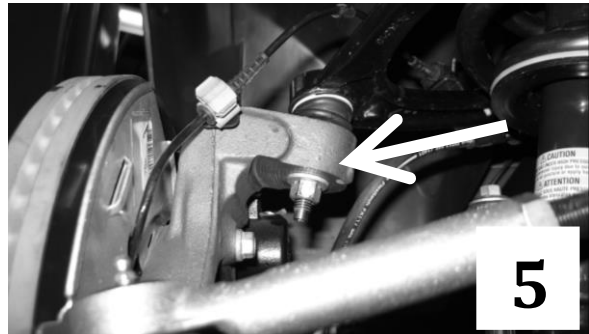

5b. Insert the top mount in to the chassis and secure with the original nuts. Torque nuts to factory specifications. (**photo 6**)

5c. Attach the lower strut mount to the lower control arm using the OEM bolts and nuts clipped to the strut. Torque to 60 ft/lbs. (**photo 7**)



5d. Re-attach the sway bar end link, upper ball joint, brake lines, and tighten to factory specifications.
(photo 8)

FINALIZING THE INSTALLATION

All hardware being fastened to the vehicle's original fastening points should be torqued to factory specifications (Reference Service Manual for Specifications). To prevent chassis damage, never over-torque the hardware.

7a. Check that all components and fasteners have been properly installed, tightened and torqued.

7b. Check brake hoses and other components for any possible interference.

7c. Lift the vehicle and remove the support stands. Carefully lower the vehicle to the ground.

7d. Immediately test-drive the vehicle in a remote location so that you can become accustomed to the revised driving characteristics and handling. Be aware that the vehicle will handle substantially different now that it has been modified.

7e. Installation is complete. Check all hardware and re-torque at intervals for the first 10, 100, 1000 miles.

PARTS LIST: 15002/16002

PART NUMBER	DESCRIPTION	QTY
15002-100/16002-100	COILOVER DAMPER	1
650-00-018	SPRING PERCH	1
601-10-122	HELPER SPRING	1
650-50-585	INTERMEDIATE RING	1
150-02-105	VENT DISCK	1
652-10-799	BUMP STOP	1
652-10-800	DUST COVER	1
5403-001	COIL SPRING	1
150-01-265	RUBBER SPRING	1
150-02-275	TOP MOUNT	1
17916F	TOP MOUNT ROD WASHER	1
17917F	TOP MOUNT NUT WASHER	1
685-25-101 (16002 ONLY)	ADJUSTMENT KNOB (RE BOUND)	1

