



INSTALLATION INSTRUCTIONS

6000 - 6010 - 6100 - 6110

6200 - 6202

Lowering Block Kit
All Truck Applications

Thank you for being selective enough to choose our high quality BELLTECH PRODUCT. We have spent many hours developing our line of products so that you will receive maximum performance with minimum difficulty during installation.

- Note: Confirm that all of the hardware listed in the parts list is in the kit. **Do not** begin installation if any part is missing. Read the instructions thoroughly before beginning this installation.
- Warning:** **DO NOT** work under a vehicle supported by only a jack. Place support stands securely under the vehicle in the manufacturer's specified locations unless otherwise instructed.
- Warning:** **DO NOT** drive vehicle until all work has been completed and checked. Torque all hardware to values specified.
- Reminder: Proper use of safety equipment and eye/face/hand protection is absolutely necessary when using these tools to perform procedures!
- Note: It is very helpful to have an assistant available during installation.

RECOMMENDED TOOLS:

- Properly rated floor jack, support stands, and wheel chocks
- Combination wrench set
- Torque wrench: *0-150 lb ft. range*
- Ratcheting socket wrench and socket sets
- Safety Glasses

WARNING:

When lowering any vehicle equipped with a rear LSPV it is recommended that the valve be re-adjusted to the manufacturer's specifications for proper braking. It is advised to have the work preformed by a qualified service facility.

A Load Sensing Proportioning Valve (LSPV) controls the appropriate braking pressure for the rear wheels based on the load level to prevent unnecessary wheel lock-up.

1. JACKING, SUPPORTING AND PREPARING THE VEHICLE

- a) Park the vehicle on a flat surface, preferably asphalt or concrete. Block the wheels on the end not being worked on so that the vehicle cannot move. Raise the end of the vehicle being worked on with a floor jack. Place the jack stands under the vehicle on a stable portion of the frame, nearest the point of the vehicle being worked on. (Figure B & D) Be sure the jack stands are rated to carry the weight of the vehicle.

CAUTION: DO NOT PUT THE STANDS UNDER THE AXLE TUBES OF THE REAR END. PUT THEM UNDER THE FRAME RAILS ONLY!

- b) Once the vehicle is on the stands, and the tension is taken off the leaf spring assemblies, (Figure B & D) let the jack remain under the axle housing to support it.
- c) Remove the stock U-bolts and nuts from the axle housing.
- d) If the axle housing is above the leaf spring, (figure B) slowly raise the jack to create space between the leaf spring and the housing. If the axle is below the leaf springs, (Figure D) slowly lower the jack to create space.
- e) Once the space has been achieved, the lowering or lift block can be placed between the leaf spring and the axle housing. Make sure that the spring center bolt (Figure A & C Item #5) locates itself in the recess on the block and the centering pin cast into the block (Figure A & C Item #4) locates itself into the centering hole on the spring perch in the axle housing. (Figure A & C Item #1)
- f) Now that blocks are in place, lower the jack so that the weight of the axle is on the block and leaf spring. If you are using lift blocks, raise the jack to push the blocks and spring together.
- g) Install the U-bolts as shown in (Figure A & C Item #2) and install the washers and nylon lock nuts, and tighten to 80 FT. pounds of torque.
- h) Once the hardware is in place and you have re-checked all the procedures, place the tires & wheels back on the vehicle. Jack the vehicle up and remove the stands from under the frame.
- i) Now, lower the vehicle back to the ground. Check under the vehicle for any clearance problems, if there is none, the installation is complete.

Note: Some states have bumper height limitations whether lifting or lowering. Please check local & state laws.

- j) Hardware being fastened to the vehicle's original fastening points should be torqued to the proper specifications. To prevent chassis damage, never over-torque the hardware.
- k) Check that all components and fasteners have been properly installed, tightened and torqued.
- l) Check brake hoses, and other components for any possible interference.
- m) Lift the vehicle and remove the support stands. Carefully lower the vehicle to ground.
- n) Immediately test-drive the vehicle in a remote location so that you can become accustomed to the revised driving characteristics and handling. Be aware that the vehicle will handle substantially different now that it has been modified.
- o) Installation is complete. Check all of the hardware and re-torque at intervals for the first 10, 100, 1000 miles.

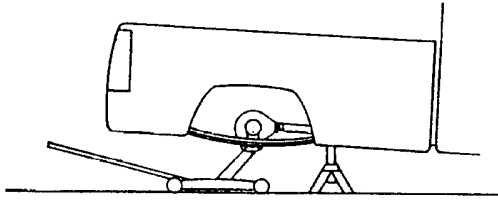

Figure B

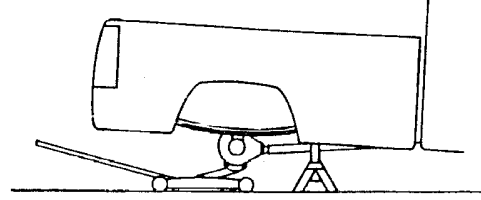

Figure D



Figure A

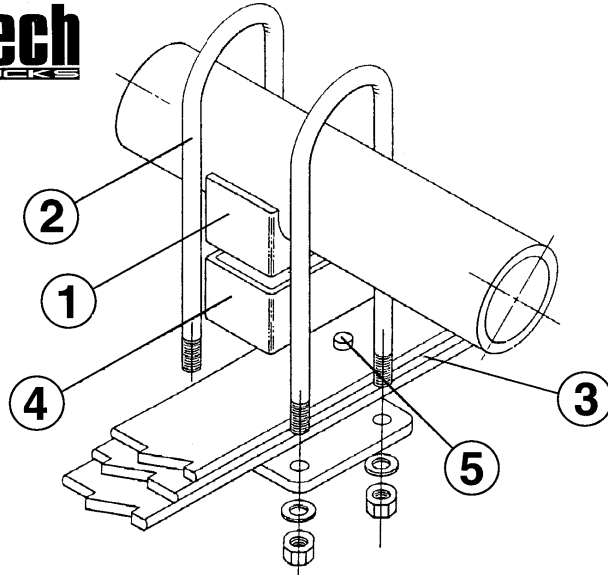
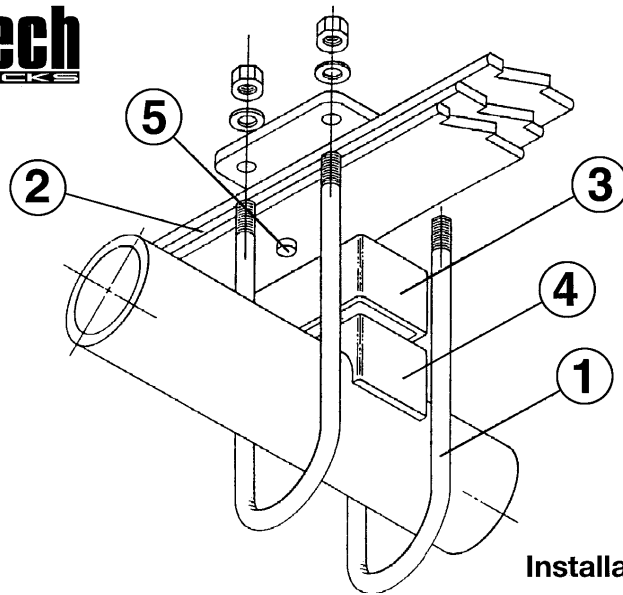

Figure C



Installation Instructions



INSTALLATION INSTRUCTIONS

2103 FRONT DROP BALL JOINT INSTALLATION INSTRUCTIONS

CHEVY COLORADO

Congratulations! You were selective enough to choose a BELLTECH PRODUCT. We have spent many hours developing our line of products so that you will receive maximum performance with minimum difficulty during installation.

Note: Confirm that all of the hardware listed in the parts list is in the kit. **Do not** begin installation if any part is missing. Read the instructions thoroughly before beginning this installation.

Warning: **DO NOT** work under a vehicle supported by only a jack. Place support stands securely under the vehicle in the manufacturer's specified locations unless otherwise instructed.

Warning: **DO NOT** drive vehicle until all work has been completed and checked. Torque all hardware to values specified.

Reminder: Proper use of safety equipment and eye/face/hand protection is absolutely necessary when using these tools to perform procedures!

Note: It is very helpful to have an assistant available during installation.

RECOMMENDED TOOLS:

- Properly rated floor jack, support stands, and wheel chocks
- Combination wrench set
- Torque wrench: *0-75 lb ft. range*
- Ratcheting socket wrench and sockets sets
- Safety Glasses
- Air ratchet
- Die grinder w/cut-off wheel or Sawzall

KIT INSTALLATION

1. The Belltech 2" Dropped Ball Joints are designed to work with factory wheels and most aftermarket wheels. Because it is not possible to test every wheel for this application, you must determine carefully that the wheels you choose do not have wheel rim contact with any of the suspension components.
2. Make sure the vehicle is on a flat surface, preferably asphalt or concrete. Block the rear wheels and set the parking brake. Raising the front of the vehicle with a floor jack, place jack stands in a stable position on the frame rails, not under the lower control arms
3. Raising the rear of the vehicle with a floor jack, place jack stands in a stable position on the frame rails. Remove the front wheel and tires. In this (Photo 2), because this particular install is being done at a professional facility, we are using car lift.

The following steps are given in sequential order. Our R & D Techs, have determined that these steps, followed in this order, gives you the quickest and simplest way to install the Drop Ball Joint without complication.

1. FRONT SENSOR LINE DISCONNECT

- a) Using a small pan-head screwdriver, by pushing in the locking clip, un-bolt the mounting bracket (Photo 1), then un-clip the three (3) mounting clips(Photo 1a) that secures the sensor line at the top of the upper ball-joint. (Photo 1)
- b) Tie-clip or using a wire the sensor line out of the way so it does not interfere with the installation.

2. TOP / BOTTOM SWAY BAR CONNECTOR ARM MOUNTS DISCONNECT

- a) Using a pair of vice-grips, lock onto the center bolt screw (Photo 2). Using a 15mm wrench, un-bolt the bottom mounting hardware on the CONNECTOR ARM, completely removing the hardware. The lower CONNECTOR ARM mount is shown mounted to the lower control arm CONNECTOR ARM ear.
- b) Using the same step as in 2a, un-bolt the top mounting hardware on the CONNECTOR ARM. (Photo 3), completely removing the hardware. This disconnects the CONNECTOR ARM from the Sway Bar, as shown in (Photo 2a)

3. STEERING TIE - ROD DISCONNECT

- a) Using an air ratchet with a 21mm long-socket, (Photo 4) loosen the mounting nut, then using a 21mm wrench, (Photo 5) un-thread the nut , but **do not** remove the nut completely.
- b) With a large hammer, strike the side of the steering arm housing two to three times until the Steering Tie-Rod frees itself. (Photo 6 & 7) **CAUTION: DO NOT** strike the nut or the tie rod itself. This will damage the part. If striking it on one side does not work, rotate the entire spindle and strike from the other side of the steering arm housing.
- c) Place a floor jack under the lower control arm and lift until a slight compression of the suspension is achieved.

4. UPPER BALL JOINT REMOVAL

- a) Locate the four mounting bolts that secure the UPPER BALL JOINT to the upper control arm. (Photo 7)
- b) Using an air ratchet, with a 21mm socket and a 21mm wrench from underneath on the nut, loosen the four (4) upper mounting hardware (Photo 8).

Remove the mounting hardware(nuts and bolts) completely out.

- c) With a large hammer strike the side of the steering arm housing two to three times until the tie-rod frees itself. **CAUTION: DO NOT** strike the nut or the tie rod itself. This will damage the part. If striking it on one side does not work, rotate the entire spindle and strike from the other side of the steering arm housing.

5. UPPER BALL JOINT INSTALLATION

- a) The UPPER CONTROL ARM SPACER TOP sits between the UPPER BALL JOINT and the top of the UPPER CONTROL ARM (Photo 9) . The UPPER CONTROL ARM SPACER BOTTOM (Photo 10) is located on the underside of the UPPER CONTROL ARM. Install the four (4) 5/16"-24 HHCS, along with the four (4) flat washers and the four (4) 5/16-24 lock nuts. (See Fig. 1)
- b) Using an air ratchet with a 5/8 socket head and a 11/16" open end wrench, tighten all four mounting hardware and secure the UPPER BALL JOINT to the UPPER CONTROL ARM.

6. LOWER BALL JOINT REMOVAL

- a) Locate the four mounting bolts that secure the LOWER BALL JOINT to the LOWER CONTROL ARM. (Photo 11)
- b) Using an air ratchet, with a 21mm socket and a 21mm wrench from underneath on the nut, loosen the four (4) upper mounting hardware (Photo 12).Remove the mounting hardware(nuts and bolts) completely out.
- c) With a large hammer strike the side of the steering arm housing two to three times until the tie-rod frees itself. **CAUTION: DO NOT** strike the nut or the tie rod itself. This will damage the part. If striking it on one side does not work, rotate the entire spindle and strike from the other side of the steering arm housing.
- d) It is here also, that the bottom strut mount can be un-bolted and disengaged from the LOWER CONTROL ARM (Photo 12a).

7. SPINDLE REMOVAL

- a) Removing both upper and lower BALL JOINT nuts, remove the SPINDLE. **CAUTION:** With the SPINDLE assembly removed, do not allow it to hang unsupported from the brake line or the sensor line. Support it using a piece of heavy gauge wire to prevent damage to any of the lines, attaching it to the vehicle frame.

8. LOWER CONTROL ARM SWAY BAR CONNECTOR ARM EAR REMOVAL

- a) In order to install the LOWER BALL JOINT, the SWAY BAR CONNECTOR ARM EAR needs to be removed (Photo 13). This EAR is welded on to the stock LOWER CONTROL ARM and can be easily removed following the steps below.
- b) **CAUTION: Always wear eye protection when using power tools and/or grinding.**
- c) Using a Sawzall, with a metal cutting blade and/or a cutting wheel, remove the EAR, cutting it flush to the top of the LOWER CONTROL ARM (Photo 13a).

- d) Once removed, using a grinder, grind the area smooth. Wipe the area down with a cleaning solvent and spray paint black. (Photo 13b)

9. LOWER BALL JOINT INSTALLATION

- a) The LOWER BALL JOINT will locate atop the LOWER CONTROL ARM (Photo 14). The bottom LOWER BALL JOINT SPACER (Photo 14a) is sandwiched between the cavity of the LOWER CONTROL ARM. This SPACER supports the LOWER CONTROL ARM from collapsing when tightening the LOWER BALL JOINT to the LOWER CONTROL ARM (Photo 14a).
- b) Install the four (4) 5/16"-24 HHCS, along with the four (4) flat washers and the four (4) 5/16-24 lock nuts. (Photo 14b)
- c) Using an air ratchet with a 5/8 socket head and an 11/16" open end wrench, tighten all four mounting hardware and secure the UPPER BALL JOINT to the UPPER CONTROL ARM.

10. RE-INSTALLING THE SPINDLE

- a) Disconnect the spindle from the temporary wire-hanger. Locate the top housing hole in the SPINDLE to the UPPER BALL JOINT. Guide the UPPER BALL JOINT into the hole and finger tight the mounting nut, but do not tighten. (Photo 15)
- b) Locate the bottom housing hole in the SPINDLE. Guide the LOWER BALL JOINT into the hole and finger tight the mounting nut, but do not tighten. (Photo 16)

11. RE-CONNECTING THE SWAY BAR CONNECTOR ARM

- a) Locate the CONNECTOR ARM lower mounting hole and install the CONNECTOR ARM. This mount is located on the new LOWER BALL JOINT. (Photo 17). Finger-tight the mounting nut.
- b) Locate the mounting hole on the SWAY BAR and pull down and install the mounting nut. Finger-tight the nut. (Photo 17a)

12. RE-CONNECTING THE STEERING TIE-ROD

- a) Locate the mounting hole in the SPINDLE ASSEMBLY. Swinging the Steering Tie-Rod upward, install the joint into the mounting hole (Photo 18). Finger-tight the mounting nut onto the joint.
- b) Using the air ratchet, tighten the Steering Tie-Rod to the mounting hole in the housing on the SPINDLE assembly.

13. RE-CONNECTING THE SENSOR LINE

- a) Install the SENSOR LINE bracket mount (Photo 19), along with the three mounting clips, attaching the SENSOR line back into the clips and back into position (Photo 19a).

14. FINALIZING THE INSTALLATION

- a) With the vehicle still off the ground, work your way back through the installation and re-tighten.

- **UPPER / LOWER BALL JOINTS Mounts – SPINDLE HOUSING**
 - Reinsert the cotter pins (top and bottom)
 - Fold cotter pins back
 - Torque to specs
- **LOWER STRUT MOUNT to LOWER CONTROL ARM Mount**
 - Torque to specs
- **SWAY BAR CONNECTOR ARM MOUNT(Lower) to LOWER BALL JOINT**
 - Torque to specs
- **SWAY BAR CONNECTOR ARM MOUNT(Upper) to SWAY BAR**
 - Torque to specs
- **STEERING TIE ROD to SPINDLE HOUSING**
 - Torque to specs

15. All hardware being fastened to the vehicles original fastening points should be torqued to the proper specifications. To prevent chassis damage, never over-torque the hardware.

16. Check that all components and fasteners have been properly installed, tightened and torqued.

17. Install the wheel and tires back onto the vehicle.

18. Check the brake hoses, and other components for any possible interference.

19. Carefully lower the vehicle to the ground.

20. Immediately test drive the vehicle in a remote location so that you can become accustomed to the revised driving characteristics and handling. Be aware that the vehicle will handle substantially different now that it has been modified.

21. Installation is complete. Check all of the hardware and re-torque at intervals for the first 10, 100, 1000 miles.

PART LIST FOR 2103 FRONT DROP BALL JOINT KIT

PART#	DESCRIPTION	QTY
2103-001	Offset Ball Joint	2
2103-015	Upper Control Arm Spacer Bottom	2
2103-016	Upper Control Arm Spacer Top	2
112082	5/16"-24 x 2 1/4" HHCS	8
110506	5-16"-24 Lock Nut	8
110204	5/16" Flat Washer	16



PHOTO 1



PHOTO 1a



PHOTO 2



PHOTO 2a

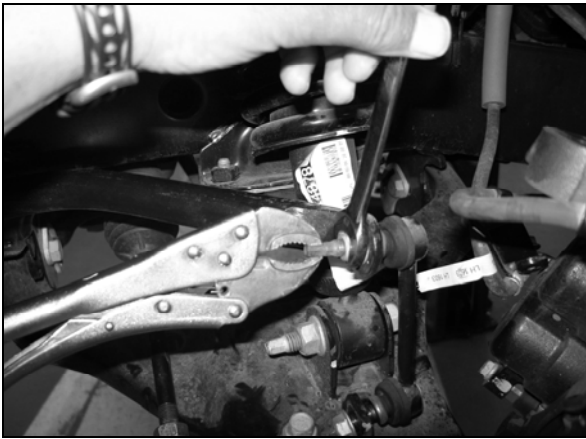

PHOTO 3



PHOTO 4

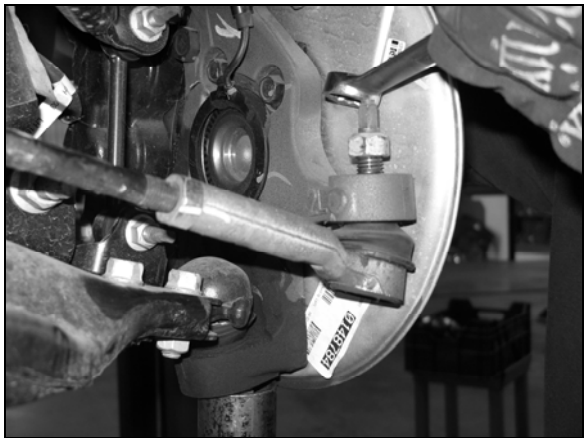

PHOTO 5

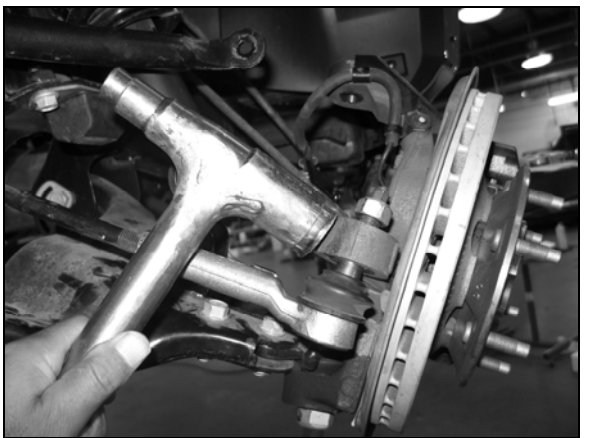

PHOTO 6

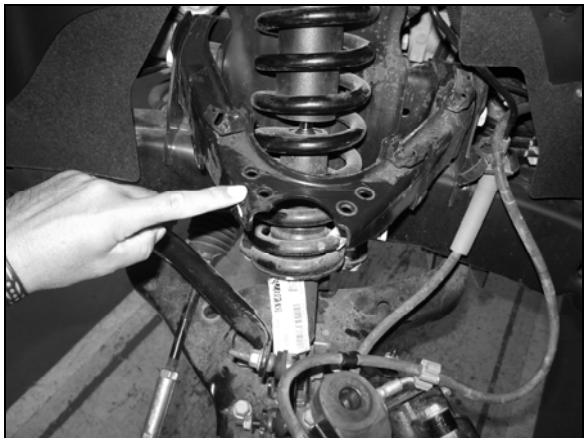

PHOTO 7



PHOTO 8

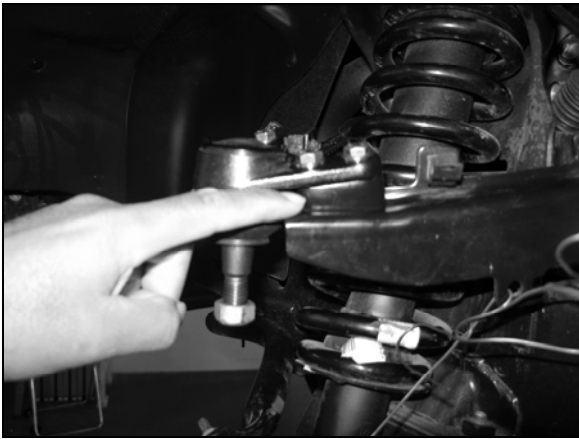

PHOTO 9

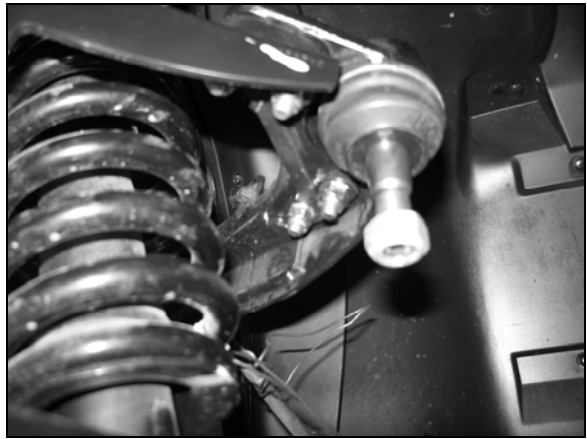

PHOTO 10



PHOTO 11

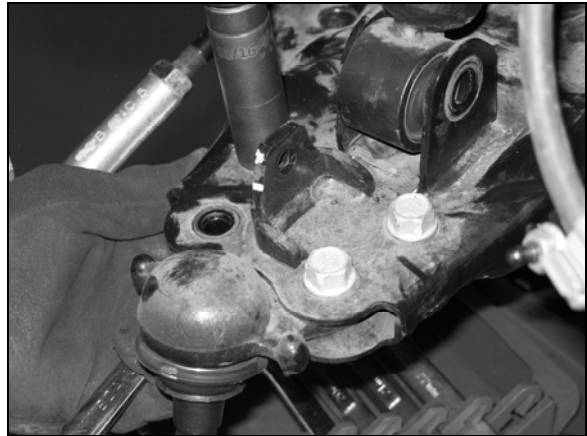

PHOTO 12



PHOTO 12a



PHOTO 13



PHOTO 13a



PHOTO 13b

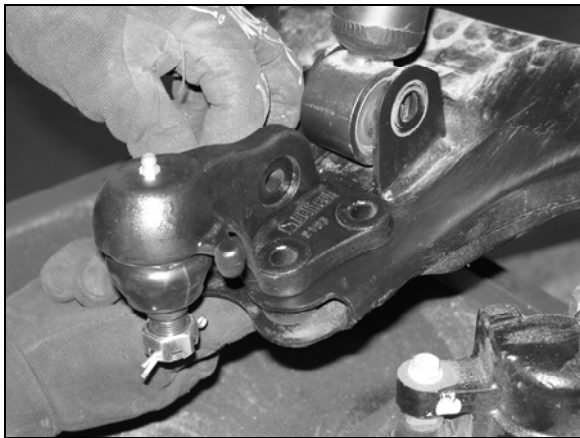

PHOTO 14

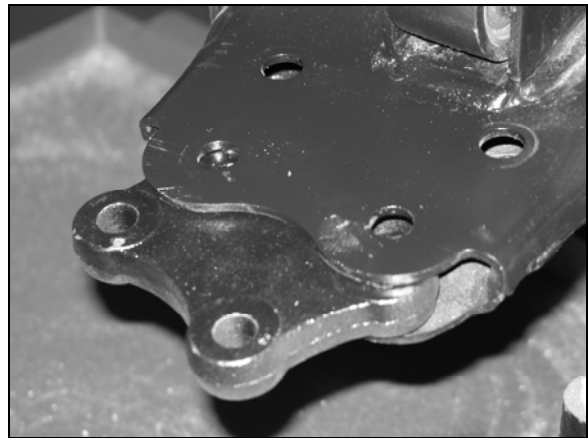

PHOTO 14a

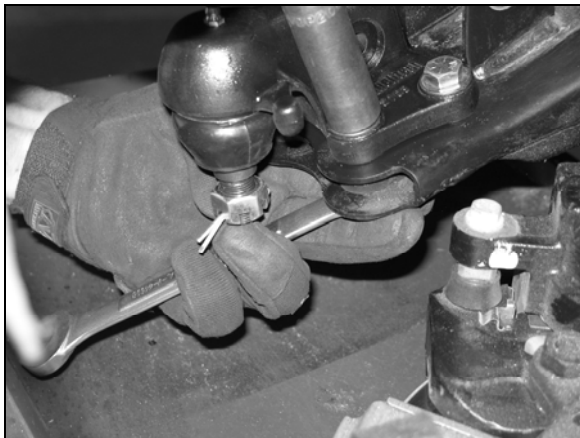

PHOTO 14b

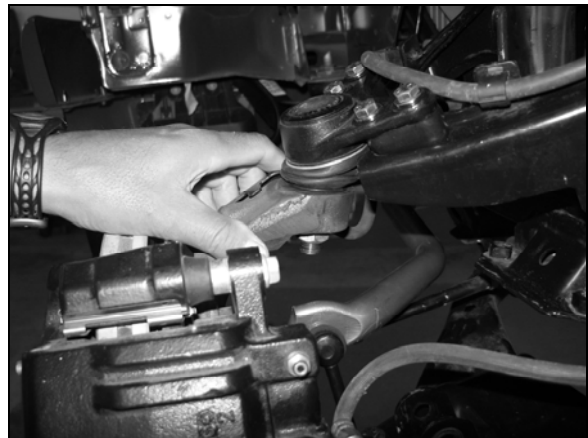

PHOTO 15

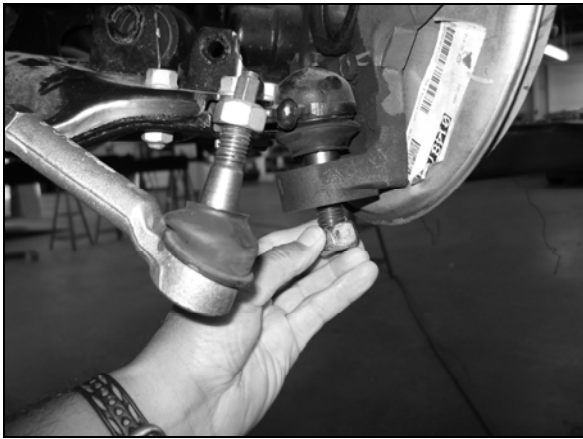

PHOTO 16



PHOTO 17

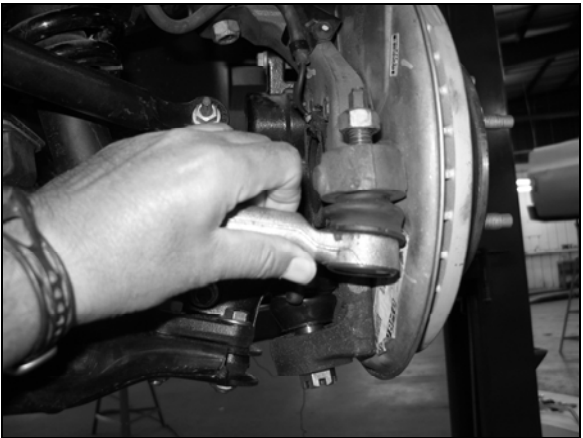

PHOTO 18



PHOTO 19



PHOTO 19a