



INSTALLATION INSTRUCTIONS

15107

LEVELING COILOVER

2021+ FORD F150 4WD 0-3" LEVELING COILOVER

Thank you for being selective enough to choose our high quality BELLTECH PRODUCT. We have spent many hours developing our line of products so that you will receive maximum performance with minimum difficulty during installation

Note: Confirm that all of the hardware listed in the parts list is in the kit. **Do not** begin installation if any part is missing. Read the instructions thoroughly before beginning this installation.

Warning: DO NOT work under a vehicle supported by only a jack. Place support stands securely under the vehicle in the manufacturer's specified locations unless otherwise instructed.

Warning: DO NOT drive vehicle until all work has been completed and checked. Torque all hardware to specified values.

Reminder: Proper use of safety equipment and eye/face/hand protection is absolutely necessary when using these tools to perform procedures!

Note: It is very helpful to have an assistant available during installation.

Exceptional Customer Experience Guarantee:

STOP! We strive for an exceptional experience for all of our valued customers. If, for any reason, you need assistance with your Belltech products, *please do not return the products to the store or website you purchased from.*

RECOMMENDED TOOLS

- Properly rated floor jack and support stands
- Combination wrench set
- Ratcheting socket wrench and socket set
- Safety glasses
- Torque wrench
- Wheel chocks
- Tape measure
- Marking pen
- Strut Spring Compressor



DIFFICULTY:



INSTALLATION TIME: 2-4hrs + Alignment

KIT INSTALLATION

WE RECOMMEND that a qualified mechanic, at a properly equipped facility, perform this installation.

WE RECOMMEND that the installation be performed on a firm, flat, and level surface such as seasoned asphalt or concrete.

The use of safe and proper equipment is very important!

Note: Before making any adjustments to your new Belltech coilover, please be sure to loosen the set screw. Failure to do so will damage the threads. After the adjustments are made, you may then tighten the set screw to keep the settings in place.

KIT PRERPERATION

- a) Before beginning the install process, measure the hub to fender heights for your vehicle so you can compare the resulting height to the original. Measure vertically from the center of the wheel to the inner edge of the fender. Record results here.

LF: _____ RF: _____

LR: _____ RR: _____

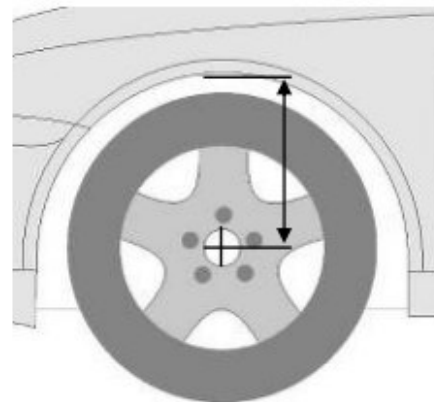
**1) JACKING, SUPPORTING AND PREPARING THE VEHICLE**

- a) Block the rear wheels of the vehicle with appropriate wheel chocks. Make sure the vehicle's transmission is in "PARK" (automatic) or 1st gear (manual). Activate the parking brake.
- b) Loosen, but **DO NOT REMOVE** the front wheel lug nuts.
- c) Lift the front of the vehicle off the ground using properly rated floor jack. Lift the vehicle so that the front tires are approximately 6-8 inches off the ground surface.
- d) Place support stands rated for the vehicles weight. The stands should be positioned in the factory specified locations. (Refer to owners manual). Prior to lowering the vehicle onto stands, make sure the support stands will contact the chassis. It is very important that the vehicle is properly supported to prevent any harm to ones self or to the vehicle.
- e) Lower the vehicle slowly onto the stands, checking that they properly and securely contacting the frame rails as described above before placing the vehicles weight completely on them.
- f) Remove the front wheels.

!SAFETY REMINDER!

Check for safe vehicle stability before proceeding under the vehicle to begin the following procedures. Never work under a vehicle supported by ONLY a jack. Always use properly rated support stands to support the vehicle.

2) OEM Strut Removal

- a) Before removing any component, mark your current alignment settings. **(Photo 1)**
- b) Working on one side at a time, loosen and remove both of the lower control arm bolts that connect the lower control arm to the frame. **(Photo 1)**
- c) Loosen and remove the nuts securing the lower strut mount to the control arm. **(Photo 2)**
- d) Push the lower control arm down until the lower strut studs are clear from the lower control arm. **(Photo 3)**
- e) Remove the 3 flanged nuts, using a 18mm wrench, securing the top of the strut to the chassis. **(Photo 4)**
- f) Drop the old strut out of the strut tower. **(Photo 5)**

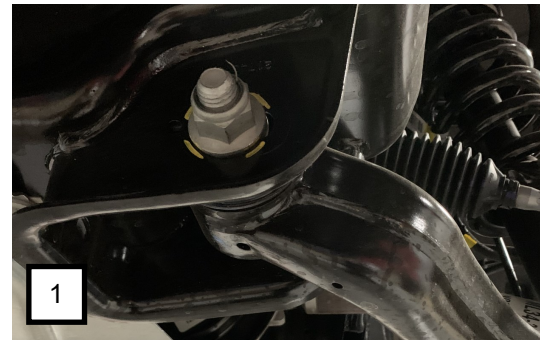

3) Coilover Setup/Assembly

!Caution! The coilover comes preassembled with 2 packers on the coilover. If your desired lift requires less packers, disassemble the coilover using proper equipment and remove unnecessary packers to meet the packer requirement shown in the table below.

- a) Refer to the vehicle lifting height table below to determine the spring perch height and the quantity of spacers for the desired lift.
- b) **Loosen the set screw in the spring perch.**
- c) Using the provided spanner wrench, turn the bottom spring perch to obtain the desired spring perch height measuring from the top of the perch to the center of the bushing. Tighten the set screw once perch adjustment is complete.

Vehicle Lifting Height Table		
Vehicle Height	Spring Perch Height ("A" Measurement)	Packers
OEM	217mm	0
1" Lift	235mm	0
2" Lift	253mm	1
3" Lift	280mm	2

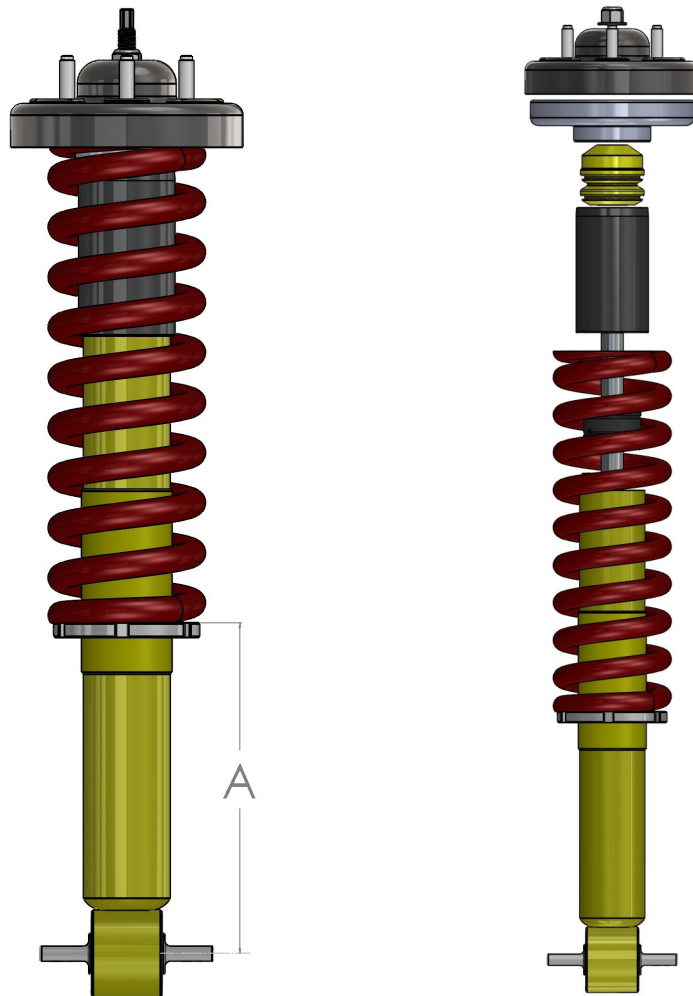

4) Coilover Installation

- a) Install the Belltech coilover into the frame strut tower. Secure the top mount with the OEM flanged nuts and torque to factory specifications. **(Photo 10)**
- b) Attach the lower strut mount to the lower control arm using the supplied flanged bolts and flanged nylock nuts. Torque to factory specifications. **(Photo 11)**
- c) Attach the lower control arm back to the frame using the OEM alignment hardware. **(Photo 12)**
- d) Set alignment settings to the markings made before removal. Torque to factory specifications. **(Photo 12)**



5) Finalizing the Installation

- a) Re-install the wheels and torque to OEM specifications.
- b) Check that all components and fasteners have been properly installed and torqued.
- c) Lift the vehicle and remove the support stands. Carefully lower the vehicle to the ground.
- d) Check brake hoses, cables, and other components for possible interference.
- e) Check for wheel/tire to chassis/body interference.
- f) Test-drive the vehicle in a remote location so that you can be accustomed to the revised driving characteristics and handling. Be aware that the vehicle will handle substantially different.
- g) Check all of the hardware and re-torque at intervals for the first 10, 100, and 1000 miles.



NOTE: Front end alignment is required immediately following the installation.

PART LIST		
P/N	ITEM DESCRIPTION	QUANTITY
68510039	100mm Spanner Wrench	1
15107-100	Belltech Coilover	2
25007-777	Hardware Kit	2

BELLTECH COILOVER LIST		
P/N	ITEM DESCRIPTION	QUANTITY
65210799	Bump Stop	1
5210800	Dust Boot	1
15002105	Vent Disc	1
65050018	Upper Spring Seat	1
65320103	Set Screw	1
70130-280	Belltech Linear Spring	1
15001-003	Coilover Spring Adapter	1
4935-001	15mm Packer	2
15001275	Top Mount	1
15107-245	Threaded Damper	1

HARDWARE KIT (25007-777)		
P/N	ITEM DESCRIPTION	QUANTITY
112307	M14x1.5-75mm Flanged Hex Bolt	2
112308	M14x1.5 Flanged Nylon Nut	2