



## INSTALLATION INSTRUCTIONS

26004

0-2" LIFTING STRUT

### 07-18 GM1500 2WD / 4WD

Thank you for being selective enough to choose our high quality BELLTECH PRODUCT. We have spent many hours developing our line of products so that you will receive maximum performance with minimum difficulty during installation.

Note: Confirm that all of the hardware listed in the parts list is in the kit. **Do not** begin installation if any part is missing. Read the instructions thoroughly before beginning this installation.

**Warning: DO NOT** work under a vehicle supported by only a jack. Place support stands securely under the vehicle in the manufacturer's specified locations unless otherwise instructed.

**Warning: DO NOT** drive vehicle until all work has been completed and checked. Torque all hardware to specified values.

Reminder: Proper use of safety equipment and eye/face/hand protection is absolutely necessary when using these tools to perform procedures!

Note: It is very helpful to have an assistant available during installation.

Note: Please refer to component and hardware list before beginning installation to insure all necessary pieces have been supplied and packaged.

#### **Exceptional Customer Experience Guarantee:**

**STOP!** We strive for an exceptional experience for all of our valued customers.

#### **RECOMMENDED TOOLS:**

- Properly rated floor jack and support stands
- Wheel chocks
- Torque wrench up to 200 ft/lbs range
- Standard and Metric socket wrench set
- Standard and Metric wrench set
- Tape measure
- Dead blow hammer
- Marking pen
- Safety Glasses

## KIT CONTENTS

<b>PART #:</b>	<b>DESCRIPTION:</b>	<b>QTY:</b>
<b>26004-200</b>	<b>LIFTING STRUT</b>	<b>1</b>
<b>25003-008</b>	<b>8mm SPACER</b>	<b>4</b>
<b>4926-001</b>	<b>BUMP STOP</b>	<b>1</b>
<b>65210031</b>	<b>VENT DISC</b>	<b>1</b>
<b>4935-001</b>	<b>15mm PACKER</b>	<b>2</b>
<b>25003-002</b>	<b>SPRING PERCH</b>	<b>1</b>



## **KIT INSTALLATION:**

Park the vehicle on a smooth, level concrete or seasoned asphalt surface and activate the parking brake. Block the REAR wheels of the vehicle with appropriate wheel chocks; making sure the vehicle's transmission is in 1st gear (manual) or "Park" (automatic).

Using a properly rated floor jack, lift the FRONT wheels of the vehicle off the ground. Place support stands rated for the vehicle's weight and in the factory specified locations. Refer to the vehicle Owner's Manual. Prior to lowering the vehicle onto the stands, make sure the supports will securely contact the chassis.

It is very important that the vehicle is properly supported during this installation to prevent personal injury and chassis damage. Make sure that the support stands are properly placed prior to performing the following procedures. We **DO NOT RECOMMEND** using wheel ramps while performing this installation.

### **REMOVE OEM STRUT:**

- a. Locate the top three mount bolts of the front spring/strut assembly.
- b. Remove all three mounting nuts that attaches the top of the spring/strut assembly to the chassis (**Photo 1**)
- c. Remove the two bottom mounting nuts of the spring/strut assembly (**Photo 2**)
- d. Remove the mount nuts from the end links. Remove the end links completely. This allows the lower control arms to droop further, to ease removal of strut. (**Photo 3**)
- e. Once all mounts have been un-bolted, hold the spindle assembly while slightly pushing down, dislodging the bottom spring/strut assembly from its bottom mounts dislodging the entire spring/strut assembly from its perch. (Photo 4)

**NOTE: BE CAREFUL NOT TO DAMAGE OR OVER EXTEND THE BRAKE HOSES WHEN REMOVING THE STRUT ASSEMBLY.**

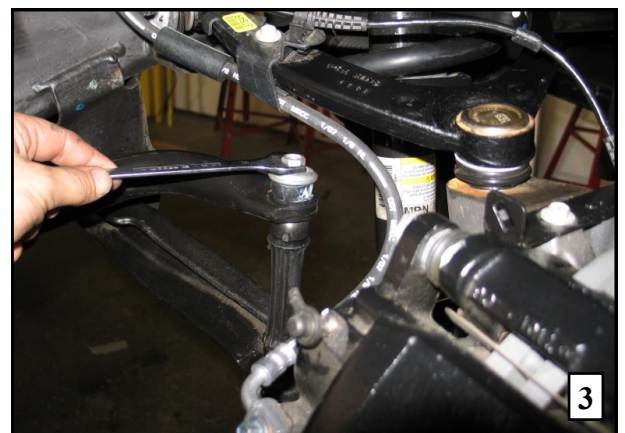

**STRUT DISASSEMBLY:**

The installation pictures shown have been done at a professional installation shop. **It is important to use a spring compressor to compress the spring before removing the top mount bolt or serious injury may occur.**

- a. Mount the entire spring/strut assembly in the fixture. **(Photo 5)**  
To ease the installation of the new strut, mark a white line down the center of the assembly for alignment purposes only showing the front of the top mount.
- b. Compress the spring until tension is relieved from the top mount.
- c. Remove the top mount nut and top spring perch.
- d. Remove the spring and strut from the fixture.
- e. Remove the OEM spacer ring (if applicable) and bump stop from the OEM strut.



**STRUT ASSEMBLY:**

**NOTE: If a half inch increment lift height is desired, add one 25003-008 ring to the shock from the next lowest increment from the table below.**

<b>2WD/4WD APPLICATION</b>				
<b>PART NO.</b>	<b>DESCRIPTION</b>	<b>OEM</b>	<b>1"</b>	<b>2"</b>
25003-008	8mm RING	0	2	4
4935-001	15mm PACKER	0	1	2



## **Strut Assembly Continued**

- a. Install your required spacers for the desired height onto the BELLTECH shock. See table / figure.
- b. Install BELLTECH spring perch onto strut once the desired combination of rings are installed.
- c. Insert the BELLTECH vent disc and packer (if applicable).

**Note: Belltech uses “Packers” to maintain the correct bump stop engagement at various lift ranges. Using the appropriate packer will prevent excessive body roll. Please place packer on top of the vent disc, channel side down as shown in Photo 6.**

- d. Insert the BELLTECH strut into the OEM spring and install the BELLTECH bump stop onto the strut
- e. Complete the assembly using the OEM spring isolator, top mount and supplied nut.

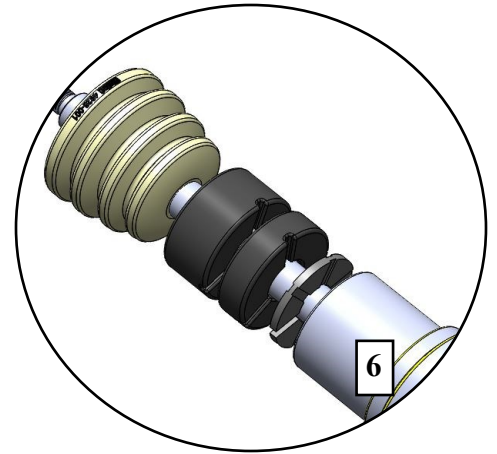

## **INSTALL THE FRONT SHOCK/SPRING**

Re-install the new assembly in reverse order of disassembly. You can use the supplied and nuts for the bottom of the new BELLTECH strut or the OEM bolts if none are provided to you.

## **FINALIZING THE INSTALLATION**

- a. All hardware being fastened to the vehicle's original fastening points should be torqued to the factory specifications (Reference Service Manual for Specifications). To prevent chassis damage, never over-torque the hardware.
- b. Check that all components and fasteners have been properly installed, tightened and torqued.
- c. Check brake hoses and other components for any possible interference.
- d. Lift the vehicle and remove the support stands. Carefully lower the vehicle to the ground.
- e. Immediately test-drive the vehicle in a remote location so that you can become accustomed to the revised driving characteristics and handling. Be aware that the vehicle will handle substantially different now that it has been modified.
- f. Installation is complete. Check all of the hardware and re-torque at intervals for the first 10, 100, 1000 miles.

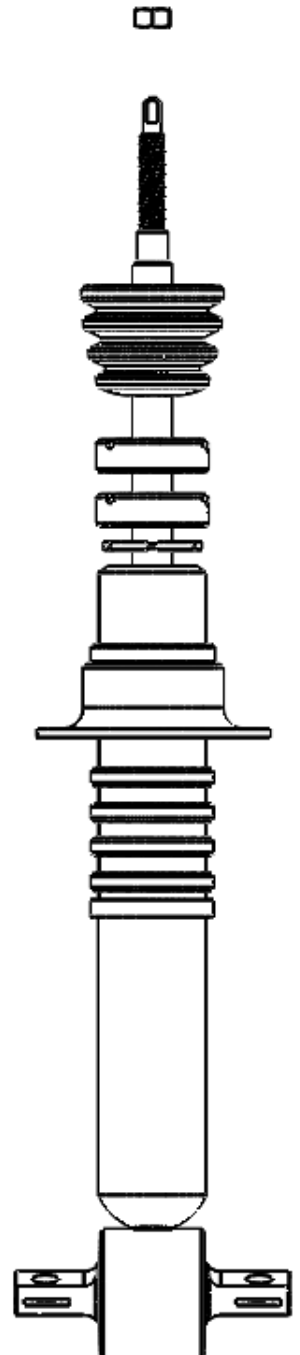



## INSTALLATION INSTRUCTIONS

**34908**

**STRUT SPACERS 07-18 Chevy 2WD / 4WD Chevy 2.0" Lift**

**Thank You for selecting a BELLTECH PRODUCT. We have spent many hours developing our line of products so that you will receive maximum performance with minimum difficulty during installation.**

**Note:** Confirm that all hardware listed in the parts list is in the kit. **Do not** begin installation if any part is missing. Read the instructions thoroughly before beginning this installation.

**Warning:** **DO NOT** work under a vehicle supported by only a jack. Place support stands securely under the vehicle in the manufacturer's specified locations unless otherwise instructed.

**Warning:** **DO NOT** drive vehicle until all work has been completed and checked. Torque all hardware to values specified.

**Warning:** Be aware that the vehicle can handle substantially different than the Manufacturers Original Design now that it has been modified.

**Reminder:** Proper use of safety equipment and eye/face/hand protection is necessary when using the recommended tools to perform procedures!

**Note:** It is very helpful to have an assistant available during installation.

### **RECOMMENDED TOOLS:**

- Properly rated floor jack, support stands, and wheel chocks
- Combination wrench set
- Ratcheting socket wrench and socket set
- Safety Glasses
- Torque wrench

### **PREPARING FOR INSTALLATION:**

- Open the hardware kit and remove contents. Refer to the part list to verify parts are present
- Park the vehicle on a smooth, level hard surface such as concrete and activate the parking brake.
- Block the REAR wheels of the vehicle with appropriate wheel chocks; making sure the vehicle's transmission is in 1st gear (manual) or "Park" (automatic).

## VEHICLE HEIGHT:

Measure the current vehicle height NOW using the "Wheel Center to Fender" method shown in Diagram below and record the numbers in the space below:

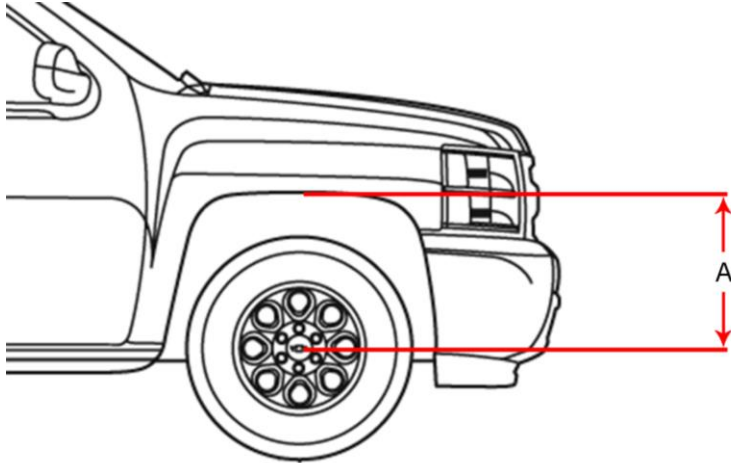

Driver Side: \_\_\_\_\_“

Passenger Side: \_\_\_\_\_“

## KIT INSTALLATION

- Remove the front wheels.
- Unbolt the Sway Bar end links
- Loosen but do not remove the upper ball joint nut now break the upper ball joint loose still do not remove the upper ball joint Nut.
- Unbolt and remove the bolt and nut from the lower strut mount.
- Remove the 3 upper Strut bolts You may need to loosen the lower control arm bolts to allow you to swing it down out of the way making it easier to remove the strut.
- Install the Belltech Strut Spacer on the top mount of the strut and tighten the three upper strut mounting bolts to 26 ft/lbs.
- Install the new assembly into the vehicle by rotating it 180 degrees from the original position.
- Install the three new upper strut mounting bolts onto the upper strut mount finger tight. **Do not tighten!**
- Install the lower strut mount and bolt.
- Now you are ready to tighten all bolts and nuts back to factory spec's
- Repeat for the other side of the vehicle

## KIT INSTALLATION CONTINUED

- Reinstall Wheels
- Lower vehicle to the ground
- All hardware being fastened to the vehicle's original fastening points should be torqued to the proper specifications. To prevent chassis damage, never over-torque the hardware.
- Check that all components and fasteners have been properly installed, tightened and torqued.
- Once vehicle is on ground check the height of the front, side to side.
- Installation is complete. Check all hardware and re-torque at intervals for the first 10, 100, 1000 miles.
- After installing the new components, a wheel alignment should be performed according to manufacturer's specifications.

## PARTS LIST FOR 34908 KIT

<b>PART No.</b>	<b>DESCRIPTION</b>	<b>QTY.</b>
34908-001	Strut Spacer	2
	Flange Nut 10MM x 1.25	6

Learn more about performance suspension parts we have.