

Product: TVK-10

Car Model: 2013 Toyota Highlander

Disclaimer:

The following is for information purpose only and we are not responsible to damage, loss or injury caused from attempting or performing the DIY. Further, the navigation and DVD lock while in motion was originally installed for safety reasons. By unlocking the navigation and DVD lock, we are assuming that the navigation and DVD will be controlled and enjoyed by the passenger(s) and not by the driver. As such, are not responsible to damage, loss or injury from using the bypass modules. Please be responsible drivers!

About the Beat-Sonic NAV/DVD Bypass Module:

System: 100% Plug and play kit from Beat-Sonic for allowing use of factory features that would be locked out during vehicle movement.

These plug and play module kits allow override of the lock out system equipped in your factory TV or Navigation/DVD system when the vehicle is in motion. Due to the fact that no modification is needed on the factory harness and this is 100% plug and play, it is easily reversible to the original factory specs without showing any signs that this modification was ever made.

The TVK-10 modules are equipped with manual functionality switch where the override of the navigation lock out may be enabled simply by toggling the switch to "TV". Once the switch is engaged, the module tricks the factory navigation system to thinking that it is at a stop and enables the use of all the controls including the navigation address input, POI, blue-tooth contacts, mp3 music select, etc. When the button is depressed, the vehicle will return to its normal state and will take couple of seconds to refresh the correct vehicle location on the map. This module will also allow Video in Motion during vehicle movement if the vehicle is equipped with a factory DVD player or any aftermarket video input device.

Installation starts here:

1. REMOVE CENTER INSTRUMENT PANEL REGISTER ASSEMBLY

- (a) Apply protective tape to the areas shown in the illustration.
- (b) Using a molding remover, disengage the 2 claws and 5 clips, and then remove the center instrument panel register assembly as shown in the illustration.

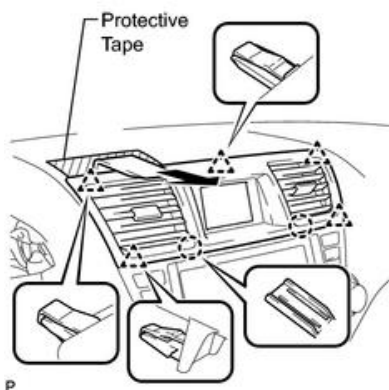

2. REMOVE CENTER INSTRUMENT CLUSTER FINISH PANEL ASSEMBLY (w/o Smart Key System)

(a) Apply protective tape to the areas shown in the illustration.

(b) Using a molding remover, disengage the 10 claws and 8 clips starting from the upper part of the center instrument cluster finish panel assembly.

NOTICE: Do not pull on the small storage compartment lid. Doing so may cause damage.

(c) Disconnect each connector and remove the center instrument cluster finish panel assembly.

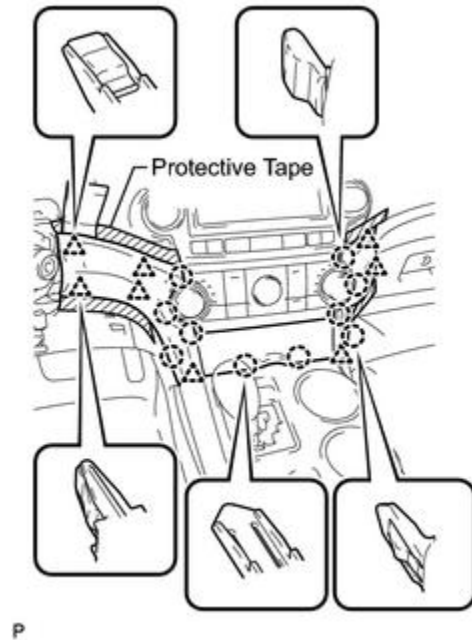

3. REMOVE CENTER INSTRUMENT CLUSTER FINISH PANEL ASSEMBLY (w/ Smart Key System)

(a) Apply protective tape to the areas shown in the illustration.

(b) Using a molding remover, disengage the 10 claws and 8 clips starting from the upper part of the center instrument cluster finish panel assembly.

NOTICE: Do not pull on the small storage compartment lid. Doing so may cause damage.

(c) Disconnect each connector and remove the center instrument cluster finish panel assembly.

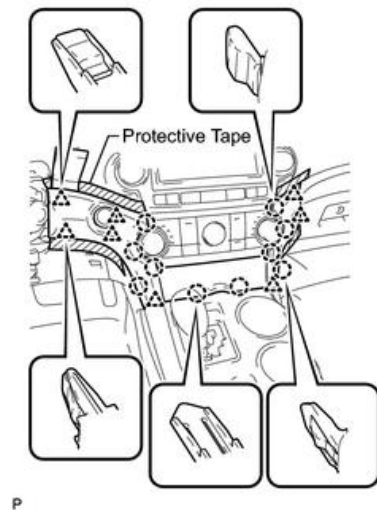

4. REMOVE HEATER CONTROL AND ACCESSORY ASSEMBLY (for Manual Air Conditioning System)

(a) Disengage the 4 clips and remove the heater control and accessory assembly.

(b) Disconnect the connector.

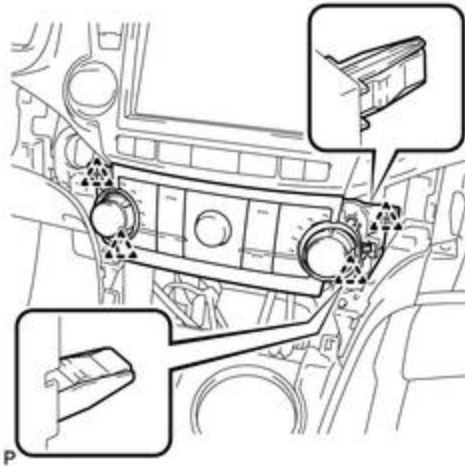

5. REMOVE AIR CONDITIONING CONTROL ASSEMBLY (for Automatic Air Conditioning System)

(a) Disengage the 4 clips and remove the air conditioning control assembly.

(b) Disconnect the connector.

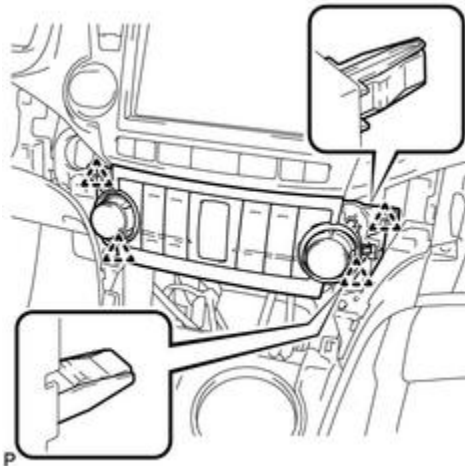

6. REMOVE NAVIGATION RECEIVER ASSEMBLY WITH BRACKET

(a) Remove the 4 bolts.

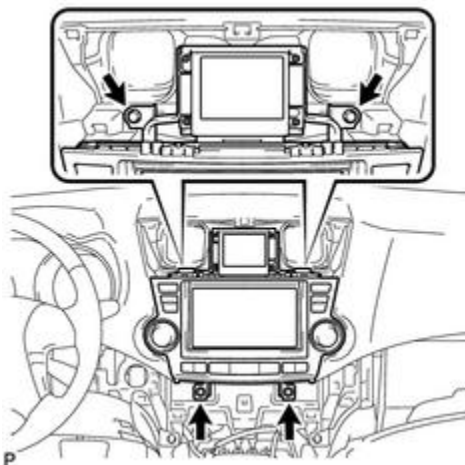

(b) Pull the navigation receiver assembly with bracket toward the rear of the vehicle and disengage the 4 clips.

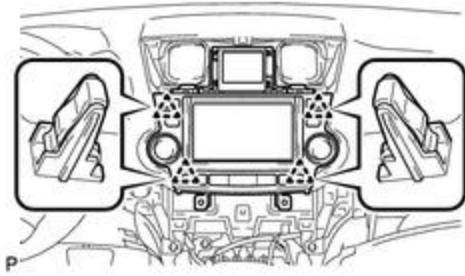

(c) Disconnect each connector and remove the navigation receiver assembly with bracket.

7. Find the matching 5-pin factory connector located behind the screen and disconnect it.

8. Connect the 5-pin connector on the TVK-10 to the same place where the 5-pin factory connector was removed from.

9. Connect the 5-pin factory connector to the unoccupied side of the TVK-10 connector.

10. Find the matching 1-pin GPS connector located behind the screen and disconnect it.

11. Connect the 1-pin connector on the TVK-10 to the same place where the factory 1-pin GPS connector was removed from.

12. Connect the factory 1-pin GPS connector to the unoccupied side of the 1-pin connector on the TVK-10.

13. Ground the black wire on the TVK-10 to the chassis. (Please avoid plastic)

14. Route the TVK-10 line and mount the toggle switch to the desired location.

TEST THE UNIT AND REVERSE PROCESS:

Test the unit to make sure it is working well and then perform the above steps in reverse to put everything back to normal and you are done!