

## MVA-23/23WD1/23WD2 User's Manual

Thank you for your purchase of MVA-23. The following document is written to describe the installation process of this product.

Vehicle Application	Model Year	Model Chassis Code
Lexus LS 430 with factory navigation	2001-2003	UCF30 , UCF31

### Features:

1. Can remove the OEM head unit and attach 2DIN size aftermarket unit/navigation with the amplifier.
2. Can use OEM navigation/TV as it is.
3. Can display the image on the factory screen(items needed are not included).

### Cautions

1. Compatible with cars with Super Live Sound System(7&9speakers) Multi-Vision(EMV).
2. Cannot use rear controller.
3. Cannot use CD changer and optional DVD changer.
4. Because of the 2ch OEM amplifier, the effect from the additional unit such as fader/DSP cannot work properly. Only when used by Multi-Vision, fader work with the additional unit.
5. Adjust the volume using both the factory unit and the new(aftermarket) unit.
6. Cannot use the OEM FM/AM radio. Need to attach the supplied antenna cable from the trunk to the back of the unit when listening to FM/AM radio using the new head unit.
7. Need the TV controller (not included) to see the TV or display the image from the new head unit on the screen of the OEM unit while driving.

### Attached panel color

MVA-23 OEM Color    MVA-23WD1 Light Brown Color

### Specification

Installation 2 DIN- 40mm Width x 26.5mm Height x 82mm Depth Weight: 150g(only adaptor)

### Included in this kit

Audio electronic adaptor , Face plate , Brackets(L/R) , Antenna cable

**Do not** Mount all components in locations that will not inhibit safe driving or obstruct the motions of the various components of the vehicle function. Be cautious so as not to damage wires, piping, tanks and other areas as installed in the vehicle. Avoid wet, dusty, or areas of extreme temperatures for installation.

**Caution** Any damages resulting to the automobile of aftermarket audio systems as result of improper installations or careless installation procedures are not covered by any warranty, nor are we responsible for any injuries or damages resulting from the installation process. Please observe caution when performing installation.

## 2 Installation of adaptor

Please make ALL of the following connections for proper operation

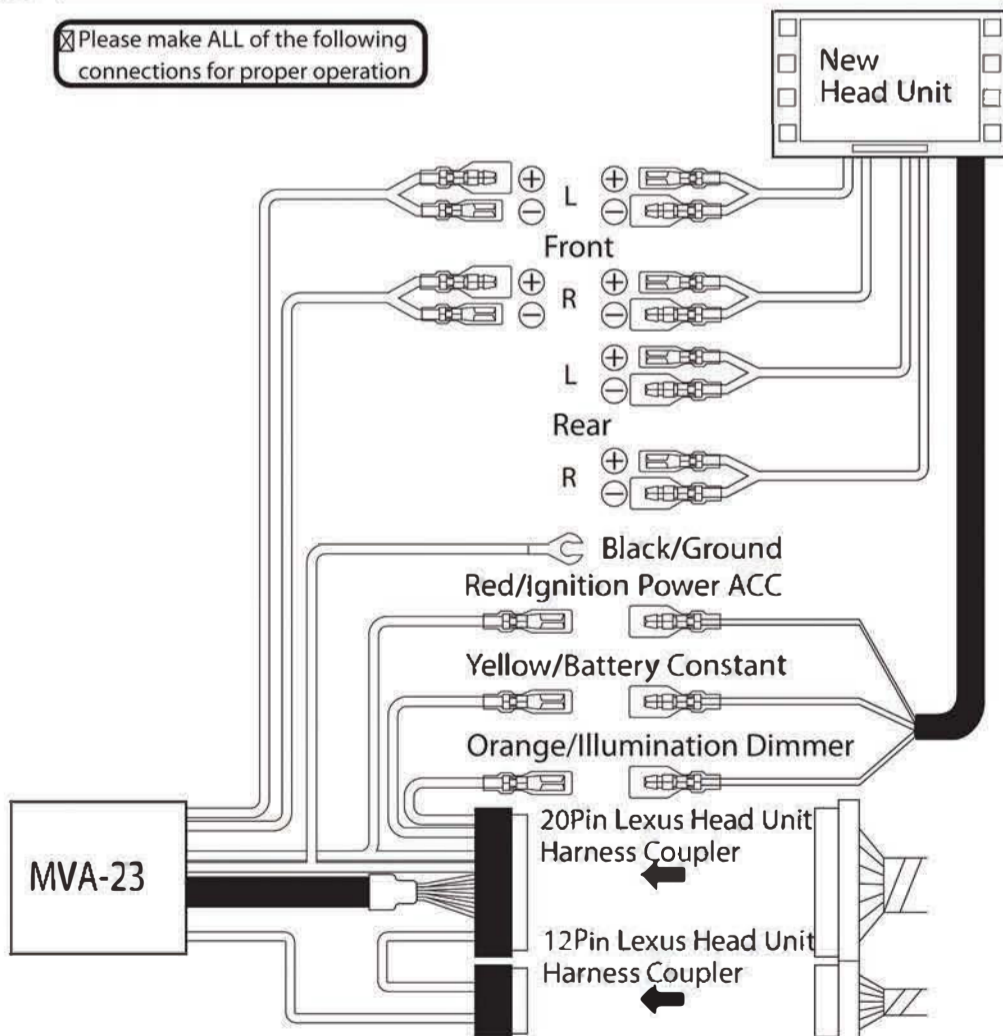

### Antenna cable connections

Connect an antenna cable to (A the right: bottom of the trunk). Remove the wiring harness attached to (A radio tuner), then attach to the extension cable. Extend the antenna plug to (C the back of the unit) through the wiring hole located in B(the back of the backseat).

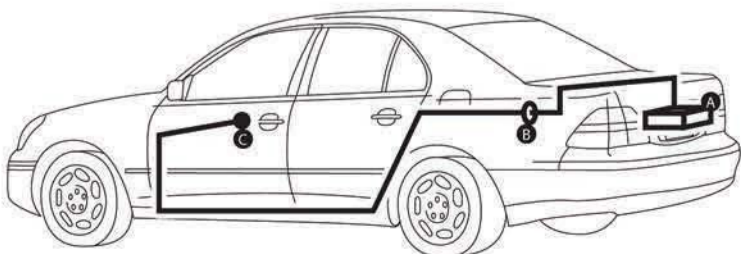

### Precautions BEFORE Installation Process

- Always disconnect the negative(-) terminal of the vehicle battery and drain all capacitors before installation.
- Use the masking tape to label the wires passing near the metal part of the car
- After the installation, make sure the brake lamps, headlights, turn signals and wipers work properly.



**Caution** Before starting installation, verify that the original audio system in the vehicle is fully functional. This kit will not remedy any issues that existed before the installation or faults in the original systems in the vehicle.

## 1 Removal of the Factory OEM Audio Head Unit

1. Remove the switch panel below the OEM unit(2 hooks)
2. Remove the center compartment(3 screws, 6 hooks).  
Remove the switches from the center compartment.
3. Remove the OEM unit(2 bolts, 2 hooks).  
Remove the hazard switch from the OEM unit(2 screws)

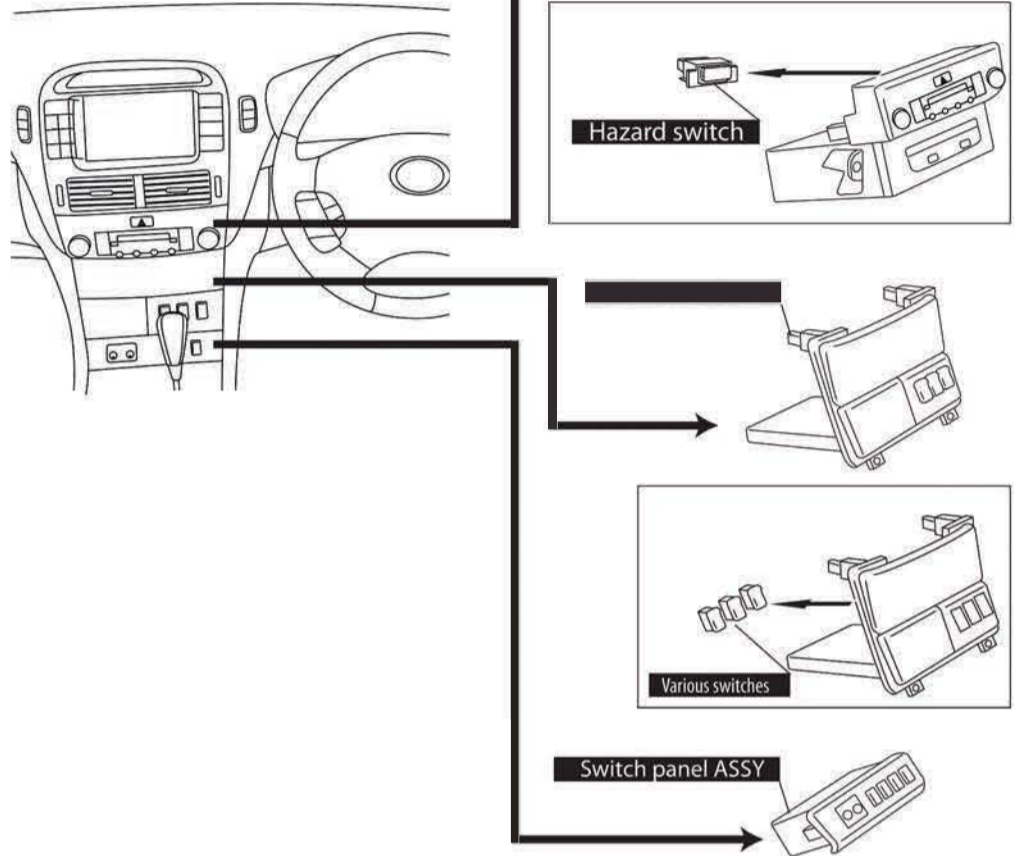

\*\*Put back the switch panel after the supplied panel.

## 3 Installation of Aftermarket Audio/NAV Head Unit

1. Secure the brackets (L/R) to the aftermarket unit using the screws(the holders and screws are supplied).

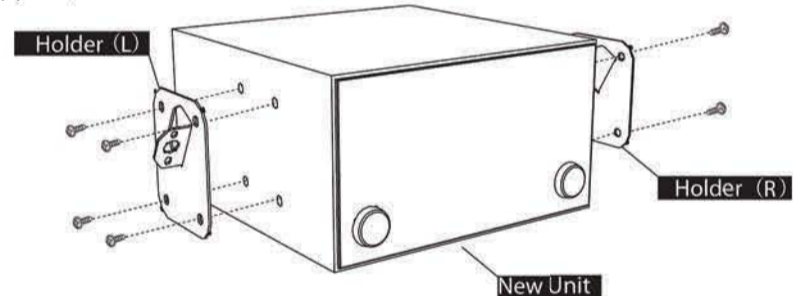

2. Clip the hazard switch (from the factory unit) and the switches (from the center compartment) into the supplied trim panel.

\*Take off the lid for the hole on the trim panel when you have more than 2 switches.

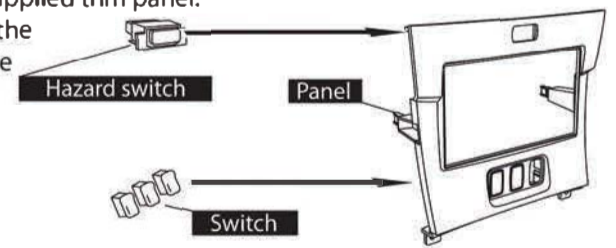

3. Slide the aftermarket unit into the cage and secure using the factory bolts (2 bolts).  
Attach the trim panel to the new head unit.

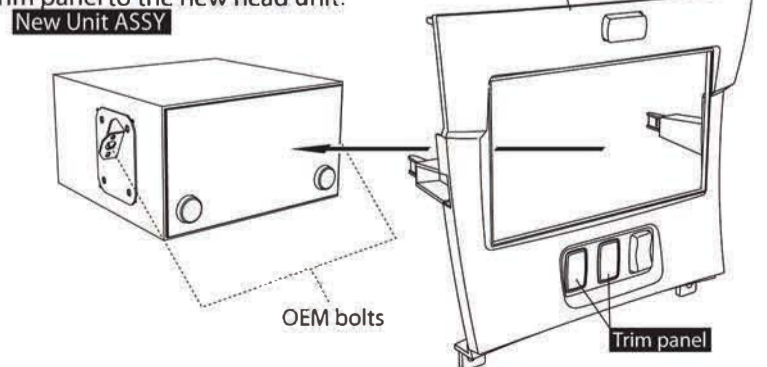

4. Attach the OEM switch panel to the dashboard.

## 4 Verify operation for the new unit

When completing the setup, make sure the audio system works properly.

## How to display the image from the new unit on the OEM screen

\*Beat-Sonic USA available accessory AVC12 is required.

\*Disconnect the OEM head unit or the new head unit to remove/attach the OEM screen.

### 5 The OEM screen disassembly

Switch the screen from the OEM NAVI to the new head unit.

**Attach AVC12(not included) to the back of the OEM screen by the following instructions.**

1. Remove the OEM head unit. See (1) The OEM head unit disassembly for the instructions.
2. Remove the temperature controls(the climate controls). (2 hooks x 2)
3. Remove the bolts behind the temperature controls (the climate controls) from the OEM screen. (2 bolts x 2)
4. Remove the OEM screen (4 hooks).
5. Attach AVC12(not included) to the back of the OEM screen.

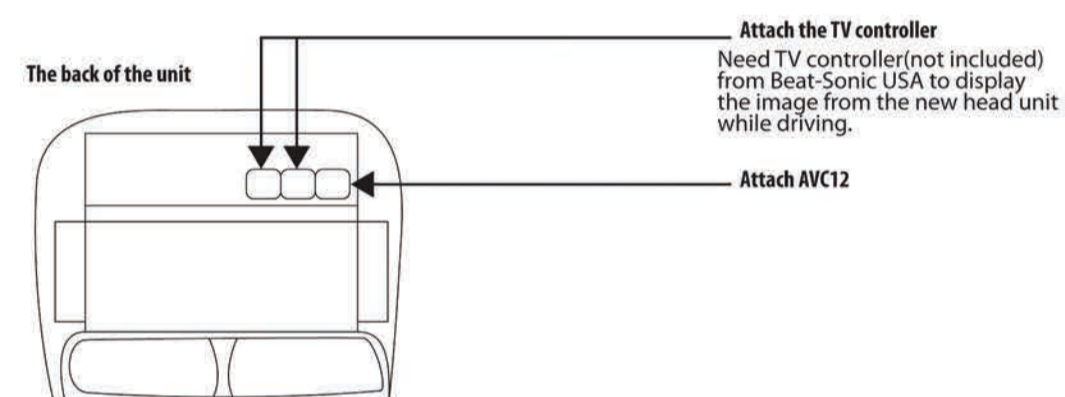
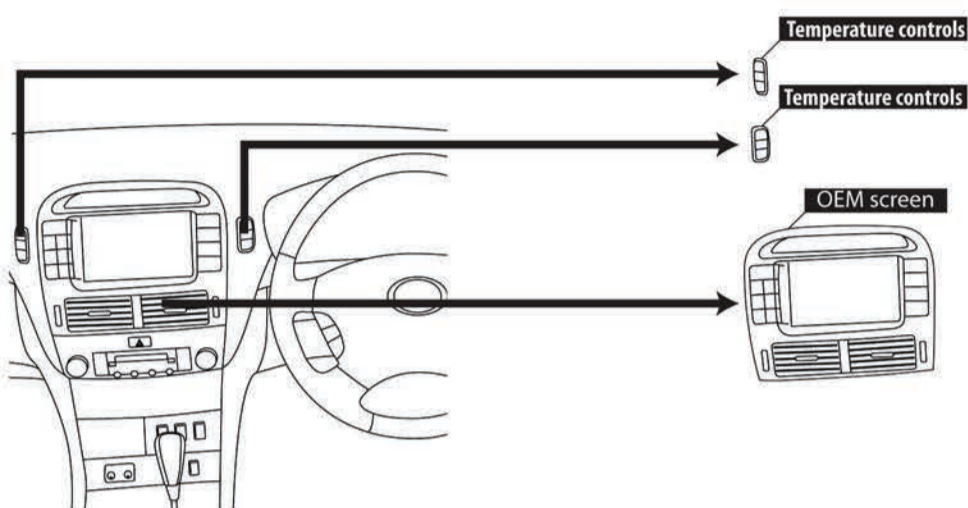

## Basic operation A

\*The following instructions do not explain how to display the image from the new head unit on the OEM screen.

\*See(Basic operation B) for the instructions.

### Display the navigation

Press the (Current Location) on the left side of the screen to display the navigation on the factory screen.

### Adjust the volume

Press the volume control button on the steering switch to adjust the volume.

## 6 AVC12 and BR02 installation

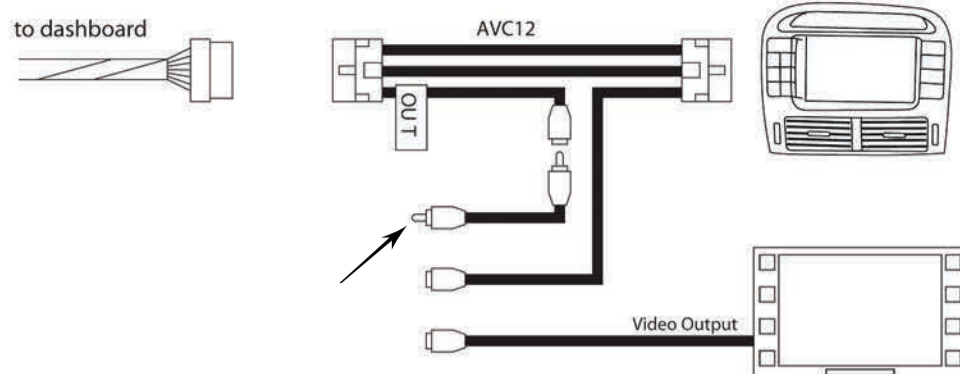

- See (2) Adaptor connections for the instructions
- Attach AVC12 to the back of the factory screen. Do not connect to MVA-23.

## 7 Test after the installation

Procedures	Suggested Solution
<input type="radio"/> Turn the ignition key to ACC	
<input type="radio"/> Press the (Current Location) on the left side of the factory screen, and display the map screen.	When no image on the factory TV, check the connection to AVC12 and BR02.
<input type="radio"/> Check if the volume changes by the volume control button on the steering switch, and adjust the volume.	When no map screen, check the connection to MVA-23.
<input type="radio"/> Check if the new head unit works properly, and adjust the volume of the new head unit	When the factory screen display black, press the (Current Location) button and display the map screen.
<input type="radio"/> Press the (AUDIO) button on the left side of the factory screen and display the image from the new head unit.	When no sound, check the connection and setting of MVA-23 and the new head unit.

## Basic operation B

The following instructions explain how to display the image from the new head unit on the factory screen.

\* AVC12, and the video cable(not included) are needed.

\*The TV controller(not included) is needed to display the image from the new unit on the factory screen while driving

### Display the image from the new head unit on the factory screen.

Press the (AUDIO) on the left side of the factory screen, and touch the (PICTURE) from the MENU of the screen. The image from the new head unit on the factory screen appears.

### Display the navigation

Press the (Current Location) on the left side of the screen to display the navigation on the factory screen.

Audio cannot be switched.

### Adjust the volume

Press the volume control button on the steering switch to adjust the volume.