

Installation instructions

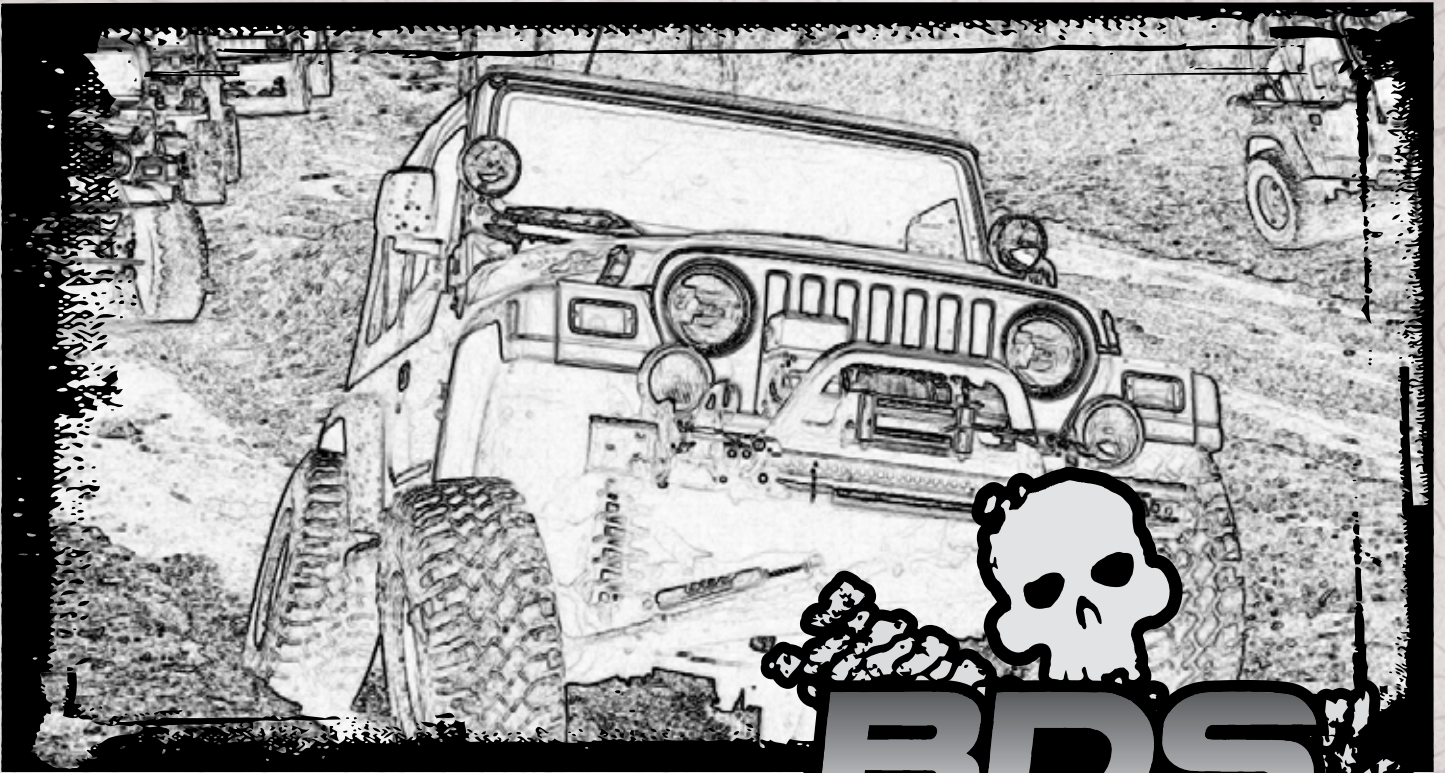

Part#: 014300, 014301

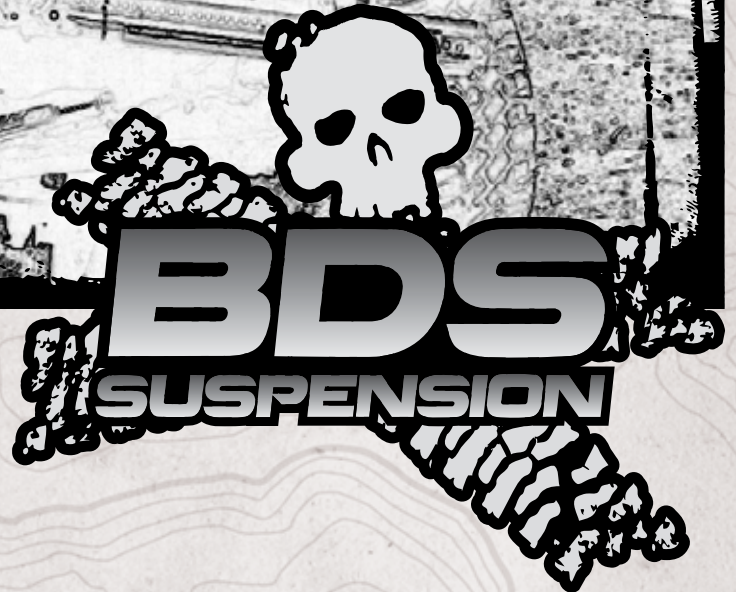

3" Suspension System

Jeep Wrangler TJ 4WD | 1997-2006

Read And Understand All Instructions And Warnings Prior To Installation Of System And Operation Of Vehicle.



THANK YOU

Your truck is about to be fitted with the best suspension system on the market today. That means you will be driving the baddest looking truck in the neighborhood, and you'll have the warranty to ensure that it stays that way for years to come.

Thank you for choosing BDS Suspension!

BEFORE YOU START

BDS Suspension Co. recommends this system be installed by a professional technician. In addition to these instructions, professional knowledge of disassembly/ reassembly procedures and post installation checks must be known.

FOR YOUR SAFETY

Certain BDS Suspension products are intended to improve off-road performance. Modifying your vehicle for off-road use may result in the vehicle handling differently than a factory equipped vehicle. Extreme care must be used to prevent loss of control or vehicle rollover. Failure to drive your modified vehicle safely may result in serious injury or death. BDS Suspension Co. does not recommend the combined use of suspension lifts, body lifts, or other lifting devices. You should never operate your modified vehicle under the influence of alcohol or drugs. Always drive your modified vehicle at reduced speeds to ensure your ability to control your vehicle under all driving conditions. Always wear your seat belt.

BEFORE INSTALLATION

- Special literature required: OE Service Manual for model/year of vehicle. Refer to manual for proper disassembly/reassembly procedures of OE and related components.
- Adhere to recommendations when replacement fasteners, retainers and keepers are called out in the OE manual.
- Larger rim and tire combinations may increase leverage on suspension, steering, and related components. When selecting combinations larger than OE, consider the additional stress you could be inducing on the OE and related components.
- Post suspension system vehicles may experience drive line vibrations. Angles may require tuning, slider on shaft may require replacement, shafts may need to be lengthened or trued, and U-joints may need to be replaced.
- Secure and properly block vehicle prior to installation of BDS Suspension components. Always wear safety glasses when using power tools.
- If installation is to be performed without a hoist, BDS Suspension Co. recommends rear alterations first.
- Due to payload options and initial ride height variances, the amount of lift is a base figure. Final ride height dimensions may vary in accordance to original vehicle attitude. Always measure the attitude prior to beginning installation.



TIRES AND WHEELS

33 x 12.50 x 15 w/ 15x9 w/ 4.5" Backspacing



BEFORE YOU DRIVE

Check all fasteners for proper torque. Check to ensure for adequate clearance between all rotating, mobile, fixed, and heated members. Verify clearance between exhaust and brake lines, fuel lines, fuel tank, floor boards and wiring harness. Check steering gear for clearance. Test and inspect brake system.

Perform steering sweep to ensure front brake hoses have adequate slack and do not contact any rotating, mobile or heated members. Inspect rear brake hoses at full extension for adequate slack. Failure to perform hose check/ replacement may result in component failure. Longer replacement hoses, if needed can be purchased from a local parts supplier.

Perform head light check and adjustment.

Re-torque all fasteners after 500 miles. Always inspect fasteners and components during routine servicing.

CONTENTS OF YOUR KIT

014300-1 Box Kit		
Part #	Qty	Description
2296	2	2" x 2" Front Bump Stop
3296	2	3" x 2" Rear Bump Stop
01326	1	Rear Track Bar Bracket
911104	2	9-3/4" Sway Bar Link
01834	1	T-Case Drop Bracket - DRV
01835	1	T-Case Drop Bracket - Pass (97-02)
A1024	2	Sway Bar Disconnect Links - Frt (Long)
B1235	1	Bag Kit - Sway Bar Links
03029	2	Sway Bar Link Sleeves
03005	2	Quick Disconnect Pin
M03212-BK-01	2	Poly Spacer Bushing
A1046	2	Disconnect Stud w/ Nut Assembly
03013	1	Disconnect Stud (1/2")
37130	1	1/2"-20 Nylock Nut
03014	2	Storage Post
03012	2	Sway Bar Link Clevis Bracket
33859	2	3/8" USS Washer
23259	2	5/16"-18 SHCS
10598-00499	2	10mm x 35mm BHSCS
10598-01212	2	10mm x 50mm BHSCS
40167	2	10mm Nylock Nut
40515	2	10mm External Tooth Lock Washer
342702	1	Loc-Tite
B996	1	Bag Kit - Hardware Packs (97-02)
704	1	Bolt Pack - Transfer Case Linkage
709	1	Bolt Pack - Rear Sway Bar Links
711	1	Bolt Pack - Track Bar Bracket Hardware
SB58BK	4	Sway Bar Link Bushings - Rear
45313	4	5/8" OD x 10mm ID x 1.375 Sleeve
54587	1	3/4" OD x 9/16" ID x 1.575 T-Bar Brkt Spacer
01420	1	TJ Transfer Case Shifter Bracket
B12X3G5	6	1/2"-13 X 3" Bolt - T-Case Drop Hardware
YJTC6	6	Tapered Washer
W76USS	6	7/16" USS Washer
200-03369	4	T-Case Drop Tube Plugs
B1080G5	2	10mm x 80mm Bolt
439	1	Bolt Pack
823801	2	TJ Lower Control Arm Cam Bolt
65077	1	1/8" x 1-1/4" Cotter Pin

014300-1 Box Kit Con't		
Part #	Qty	Description
2296	2	2" x 2" Front Bump Stop
3296	2	3" x 2" Rear Bump Stop
01326	1	Rear Track Bar Bracket
911104	2	9-3/4" Sway Bar Link
01834	2	T-Case Drop Bracket
A1024	2	Sway Bar Disconnect Links - Frt (Long)
B1235	1	Bag Kit - Sway Bar Links
03029	2	Sway Bar Link Sleeves
03005	2	Quick Disconnect Pin
M03212-BK-01	2	Poly Spacer Bushing
A1046	2	Disconnect Stud w/ Nut Assembly
03013	1	Disconnect Stud (1/2")
37130	1	1/2"-20 Nylock Nut
03014	2	Storage Post
03012	2	Sway Bar Link Clevis Bracket
33859	2	3/8" USS Washer
23259	2	5/16"-18 SHCS
10598-00499	2	10mm x 35mm BHSCS
10598-01212	2	10mm x 50mm BHSCS
40167	2	10mm Nylock Nut
40515	2	10mm External Tooth Lock Washer
342702	1	Loc-Tite
B997	1	Bag Kit - Hardware Packs (03-06)
704	1	Bolt Pack - Transfer Case Linkage
709	1	Bolt Pack - Rear Sway Bar Links
711	1	Bolt Pack - Track Bar Bracket Hardware
716	1	Bolt Pack - Transfer Case Drop (03-06)
SB58BK	4	Sway Bar Link Bushings - Rear
45313	4	5/8" OD x 10mm ID x 1.375 Sleeve
54587	1	3/4" OD x 9/16" ID x 1.575 T-Bar Brkt Spacer
01420	1	TJ Transfer Case Shifter Bracket
200-03369	4	T-Case Drop Tube Plugs
B1080G5	2	10mm x 80mm Bolt
439	1	Bolt Pack
823801	2	TJ Lower Control Arm Cam Bolt
65077	1	1/8" x 1-1/4" Cotter Pin

Hardware Breakdown

Part #	Qty	Description
439		Bolt Pack
	2	3/8"-16 x 2-1/2" Bolt
	2	3/8" USS Washer
	1	3/8"-16 x 1" Self Threading Bolt
704		Bolt Pack
	2	1/4"-20 Prevailing Torque Nut
	2	1/4" SAE Washer
709		Bolt Pack
	4	10mm-1.50 x 60mm Bolt
	4	10mm-1.50 Prevailing Torque Nut
	8	3/8" USS Washer
711		Bolt Pack
	2	5/16"-18 x 7/8" Bolt
	2	5/16-18 Prevailing Torque Nut
	2	5/16" USS Washer
	4	5/16" SAE Washer
	1	3/8"-16 x 1" Bolt
	1	3/8"-16 Prevailing Torque Nut
	2	12mm-1.75 x 80mm Bolt
	2	12mm-1.75 Prevailing Torque Nut
	4	1/2" SAE Washer
716		Bolt Pack *014301 ONLY*
	6	12mm-1.75 x 70mm Bolt
	6	12mm Washer

TROUBLESHOOTING INFORMATION FOR YOUR VEHICLE

1. Older vehicles may have the control arm bolts frozen into the control arms. If this occurs replacement arms are highly recommended.

**TECH
TIPS**

INSTALLATION INSTRUCTIONS

INSTALLATION INSTRUCTIONS

1. Park the vehicle on a clean, flat surface and block the rear wheels for safety.
2. Measure from the center of the wheel up to the bottom edge of the wheel opening

LF _____ RF _____ LR _____ RR _____

3. Remove the forward transmission skid plate. Remove the two frame mount bolts (one per side) and three center skid plate bolts. Remove skid plate from vehicle.
As a result of the increased suspension travel obtained by the addition of this suspension system, the forward transmission skid plate cannot be reinstalled. Installation of this skid plate will result in contact between the front driveshaft and skid plate crossmember throughout normal suspension travel, possibly damaging the driveshaft.

SPECIAL TOOLS

5/16"-18 Tap
7/64" Drill Bit

FRONT INSTALLATION

4. Disconnect the front track bar from the passenger's side of the front axle (Fig 1). Retain hardware.

FIGURE 1



5. Raise the front of the vehicle and support with jack stands at the frame rails just behind the lower control arm pockets.
6. Support the front axle with a hydraulic jack.
7. Remove the wheels.
8. Remove the OE shocks. Discard the shocks and upper mounting hardware. Retain the lower mounting bolts/nuts.

9. Remove the upper mounting nut from the sway bar links (Fig 2). Disconnect the links from the sway bar using a pickle fork to release the tapered seat.

FIGURE 2

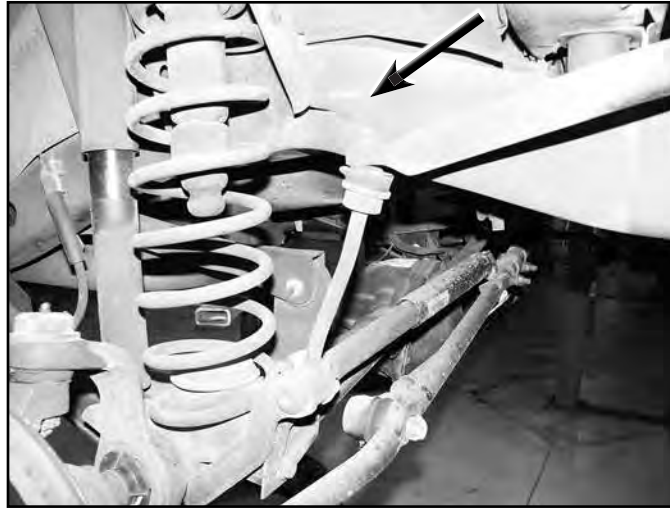

10. Disconnect the sway bar links from the axle. Remove the OE lower sway bar link bolt from the axle bracket. This bolt has a serrated neck that is set in the bracket so it cannot rotate in the bracket. It will need to be pounded out with a hammer or pressed out with an appropriate puller. Discard bolt and
11. Disconnect the drag link from the pitman arm (Fig 3). Retain OE castellated nut.

FIGURE 3



12. If equipped, remove the coil spring retainer clips from the coil mount on the axle. Retain clip and bolt.
13. Remove lower control arm-to-axle bolt. Discard hardware, it will be replaced with the new provided eccentric bolts.
14. Lower the axle and remove the coil spring. Take care not to overextend any lines or hoses.

15. Drill the center holes in the lower spring mounts using an 11/32 or T size drill. Use the self tapping bolt located in bolt pack 439 to cut 3/8" threads (Figure 4).

FIGURE 4



16. Install the new coil spring (034302) along with the provided 3" dia. x 2" tall bump stop spacer. Rotate the coil so it is seated properly in the axle mount. Install the OE spring retainer clip with the original bolt and torque to 20 ft-lbs. Once again, take care not to overextend any lines or hoses while installing the springs. Fasten the bump stop extensions to the axle with the 3/8 x 2-1/2" bolts and washers (BP 439).
17. Once both sides are complete, install the lower control arms in the axle mounts and fasten with the provided eccentric bolts, washers and nuts (82380). Snug the hardware just so the cams are in the mounts. The bolt should still turn freely. Final torque will be done with the weight of the vehicle on the suspension.
18. Locate the OE track bar mount on the passenger's side of the axle. A new track bar mounting hole must be drilled in the bracket. Measure 3/4" from the center of the OE hole to the driver's side and mark. Drill a 13/32 hole at the mark.

Note: Make sure that there will be adequate material left between the new hole and the edge of the bracket, if not move the hole location up slightly. Do not install the track bar in the bracket at this time.

19. Attach the drag link to the pitman arm with the OE castellated nut and supplied new cotter pin. Torque nut to 60 ft-lbs. *Note: Never loosen the castellated nut to align the cotter pin hole, always tighten.*
 20. The BDS front sway bar disconnects (A1024) come pre-assembled with the hourglass bushings installed. Lightly grease and install the provided sleeve (03029) in the sway bar link bushings. Adjust length of sway bar links to 10-3/4", securely lock off jam nut.
 21. Install new stainless steel lower sway bar disconnect post with 1/2" Nylock Nut. Tighten to 65 ft-lbs.
- Note: It may be necessary to clean the axle mount hole of burrs from the OE serrated mounting bolt to provided clearance for the new ball stud.*

FIGURE 6



22. Install the provided upper u-bracket (03012) to the TOP side of the sway bar with the threaded end towards the center of the vehicle. Attach with 10mm x 35mm hardware. Square the bracket up to the frame and tighten to 40 ft-lbs. (Fig 7a)

FIGURE 7A



23. Install the sway bar link assembly to the upper u-bracket with the provided 10mm x 50mm button head bolt with loc-tite on threads and external tooth lock washer. (Fig 7b)

FIGURE 7B

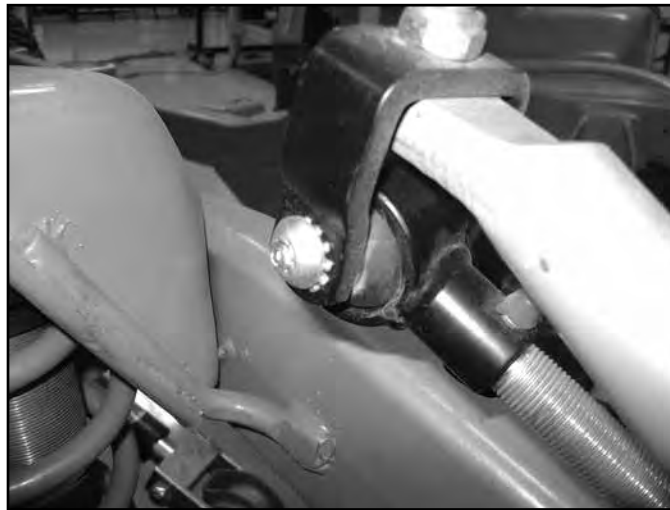

24. Swing the sway bar up and locate an area on the frame rail to install the sway bar link retaining pin that will allow the sway bar to cycle through full motion. Mark center of bushing and drill hole to 17/64" and tap to 5/16"-18. Attach disconnect pin with 5/16-18 x 1-1/2" SHCS with loc-tite on threads. (Fig 8a)

FIGURE 8A



25. Install disconnect pins into the sway bar studs as shown. (Fig 8b)

FIGURE 8B

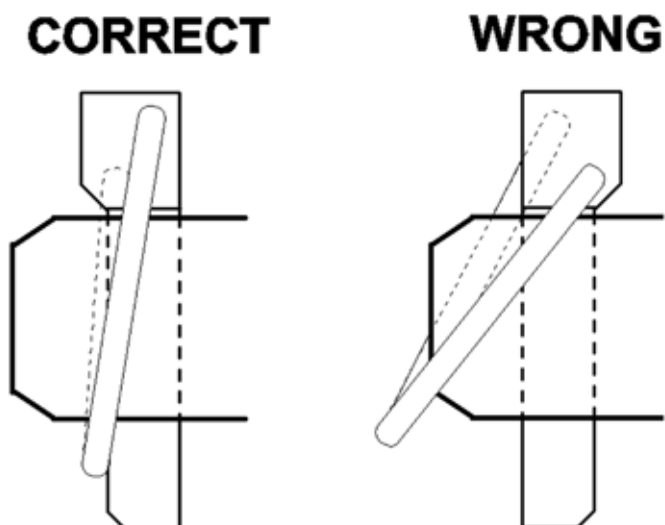

26. Install the appropriate BDS shocks with the new upper hardware and OE lower hardware. Tighten the upper nut until the bushing begins to swell. Torque the lower hardware to 22 ft-lbs.
27. Install the wheels and lower the front of the vehicle to the ground.
28. Install the track bar in the new hole that was drilled earlier in the axle mount with the OE bolt and nut tab. Turn the steering wheel will help to line up the track bar with the hole. Torque the bolt to 40 ft-lbs.

REAR INSTALLATION

1. Block the front wheels for safety. Raise the rear of the vehicle and support with jack stands under the frame rails just ahead of the lower control arm mounts.
2. Remove the wheels.
3. Support the axle at the differential with a hydraulic jack.
4. Disconnect the track bar at the passenger's side frame (Fig 9). Retain hardware.

FIGURE 9

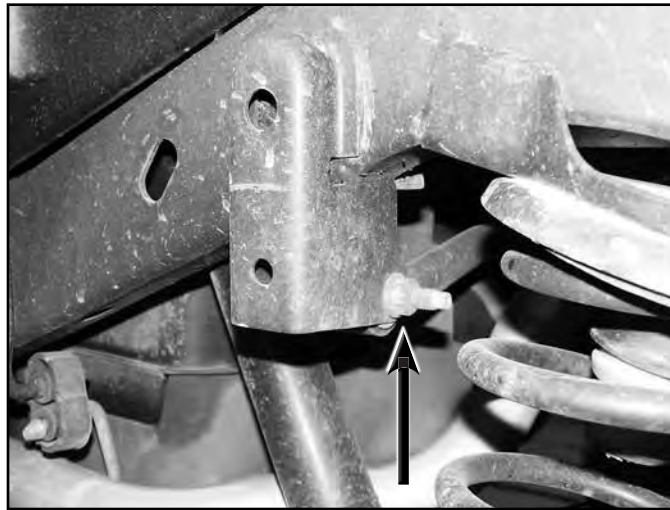

5. Remove the OE rear shocks. Retain the upper and lower mounting hardware.
6. Remove the OE sway bar links (Fig 10). The links will not be reused.

FIGURE 10



7. Disconnect the lower control arms from the axle. Retain hardware.
8. Lower the axle until the coil springs can be removed. Take care not to over-extend any lines or hoses.
9. Remove the OE rubber bump stop from the upper coil mount. Large pliers can be used to pull it out. Remove the OE bump stop retainer cup by remove the bolt from the center of the cup.

10. Install the provided bump stop spacer (2296) between the OE retainer cup and the frame with a 10mm x 80mm bolt. Use Loctite on the bolt threads and torque to 30 ft-lbs. Install the OE bump stop in the retainer cup (Fig 10).

Note: A small amount of grease will ease installation of the bump stop.

FIGURE 10



11. Remove the plastic cover from the track bar mount on the driver's side of the axle (Fig 11). Discard the cover.

FIGURE 11

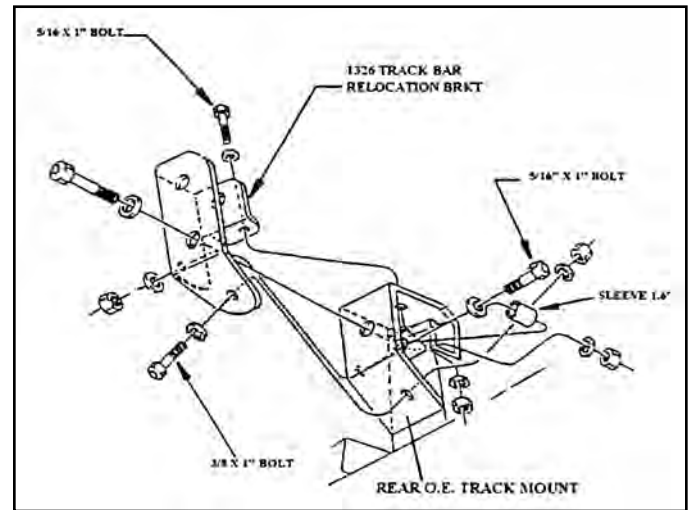

12. Disconnect the track bar (Fig 11) from the axle by remove the Torx head bolt (T55). Note how the track bar is positioned in vehicle. It can rest in the vehicle or be removed for reinstallation later.
13. Position the supplied track bar relocation bracket (01326) on the original track bar axle mount (Fig 12). Install the supplied 1.600" long sleeve (6-1) in the original track bar mounting point (Fig 13). Install a provided 12mm x 80mm bolt and 7/16" washer (BP 711) through the supplied bracket, OE mount, sleeve and out through the other side of the mount. Loosely fasten the bolt with the OE nut tab. Note: If the OE nut tab is damaged, use a provided 12mm nut (BP 711).

FIGURE 12**FIGURE 13**

14. Using the new bracket as a template, mark the two additional mounting holes to be drilled. Note: The lowest hole in the bracket will line up with an existing hole that may need to be widened slightly.
15. Remove the bracket and drill 5/16" holes at the top two marks and widen the lower hole, if necessary, to accept the 3/8" bolt.
16. Reinstall the bracket as instructed before in addition to install the provided 5/16" x 1" bolts, nuts and washers (BP 711) in the upper two newly drilled mounting holes and the 3/8" x 1" bolt, nut and washers (BP 711) in the lower hole. Leave hardware loose until all bolts are installed.
17. Torque all mounting bolts: 12mm hardware- 60 ft-lbs, 3/8" hardware- 30 ft-lbs, 5/16" hardware- 15 ft-lbs. Install the track bar in the new track bar bracket with the provided 12mm x 80mm bolt, nut and 7/16" USS washers. Be sure to run the bolt from back to front. Leave bolt loose at this time.
18. Install the provided new coil springs (034308).
19. Install the appropriate BDS shocks OE upper and lower hardware. Torque the lower hardware to 60 ft-lbs. Torque the upper hardware to 22 ft-lbs.
20. Reinstall the lower control arms in the axle mounts with the OE hardware. Leave hardware loose.
21. The new rear sway bar links (911104) come with the bushings already installed. Lightly grease and install the provided sleeves (45313) in each of the bushings.
22. Install the rear sway bar links to the original frame mount and the sway bar with the provided 10mm x 60mm bolts, nut and washers (BP 709). Torque the bolts to 30 ft-lbs. The OE 10mm nut tab can be reused at the frame.
23. Install the wheels and lower the vehicle to the ground. *Note: Make sure the track bar doesn't get pitched when lowering the vehicle.*
24. Torque the lower control arm bolts at the axle to 125 ft-lbs.
25. Attach the track bar to the original frame mount with the OE hardware. The body may need to be shifted slightly side-to-side to align the bolt. Torque both upper and lower track bar bolts to 60 ft-lbs.

97-02 MODELS - TRANSFER CASE LOWERING KIT

26. Support the transfer case skid plate with a floor jack.
27. Locate both of the transfer case drop spacer tubes and the (4) plastic caps. Lightly tap the caps squarely into the ends of the spacer tubes until fully seated.
28. Loosen but do not remove all six skid plate mounting bolts.
29. Remove the three bolts on the drivers's side mounting the skid plate to the frame. Locate the longer transfer case spacer tube. Slowly lower the jack until the tube can be installed between the skid plate and the frame. With the large holes facing up, line up the holes at each mounting bolt location.
30. Attach the skid plate and transfer case drop with the provided 1/2" x 3" bolts, 7/16" USS washers, and conical washers (Fig 14). Leave bolts loose.

FIGURE 14

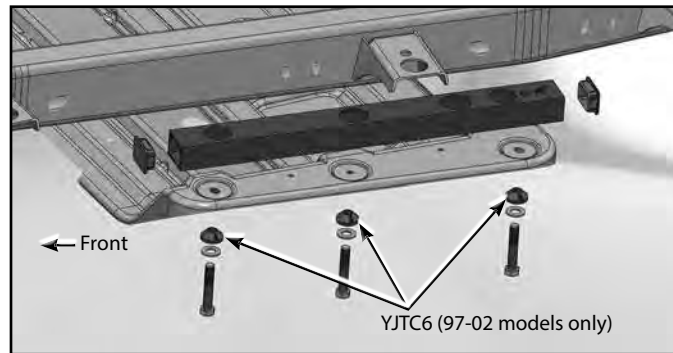

31. Repeat the procedure for the passenger's side of the skid plate.
32. With all six bolts and tube spacers installed, torque the bolts to 65 ft-lbs.

Note: Some models may experience interference between the transfer case and the skid plate. It will be necessary to trim the pan in these cases to obtain clearance.

03-06 MODELS - TRANSFER CASE LOWERING KIT

33. Support the transfer case skid plate with a floor jack.
34. Locate both of the transfer case drop spacer tubes and the (4) plastic caps. Lightly tap the caps squarely into the ends of the spacer tubes.
35. Loosen but do not remove all six skid plate mounting bolts.
36. Remove the three bolts on the driver's side mounting the skid plate to the frame. Slowly lower the jack until one of the spacer tubes can be installed between the skid plate and the frame. With the large holes facing up, line up the holes at each mounting bolt location.
37. Attach the skid plate and transfer case drop with the provided, 12mm x 70mm bolts and 12 mm flat washers. (Fig 14). Leave bolts loose.
38. Repeat the procedure for the passenger's side of the skid plate.
39. With all six bolts and tube spacers installed, torque the bolts to 65 ft-lbs.

Note: Some models may experience interference between the transfer case and the skid plate. It will be necessary to trim the pan in these cases to obtain clearance.

SHIFT LINKAGE RELOCATION

40. Remove the two bolts mounting the transfer case shift linkage pivot bushing to the pivot bracket. This is located on the underside of the driver's side floorboard.
41. Remove the pivot bracket from the floorboard. Pull up the carpet in front of the driver's seat to access the four bracket mounting bolts. Remove the bolts and remove the bracket and bushing from the vehicle.
42. Mount the pivot bushing relocation bracket (01420) to the OE bracket with the original bushing hardware (Fig 15). Torque bolt to 10 ft-lbs.

FIGURE 15

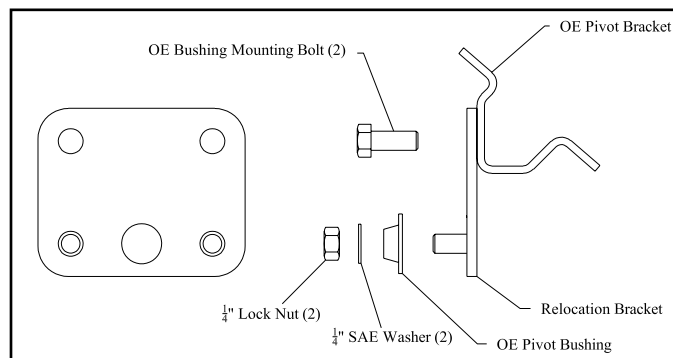

43. Mount the pivot bushing to the relocation bracket threaded studs (with OE gasket, if equipped). Fasten the bushing with the provided 1/4" nuts and washers (BP 704). Torque 1/4" nuts to 10 ft-lbs.
44. Install the modified bracket assembly in the original location on the underside of the floorboard by sliding the linkage rod through the pivot bushing. Fasten the bracket to the original mounting holes with the OE hardware. Torque bolts to 15 ft-lbs.

POST INSTALLATION

1. Check the vehicle for any interference of any moving parts. Check all brake and fuel lines. Perform a steering sweep to ensure full turning radius without interference.
2. Double check all fasteners for proper torque.
3. Install warning card rear view mirror for vehicle operator.
4. A complete front end alignment should be performed after the installation of this kit. A head light adjustment should also be performed.
5. The steering wheel can be centered by adjusting the front steering center link.
6. Check all fasteners after 500 miles.